

JUNE 2012

# National Grid Electricity Transmission's System Operator incentives overview

nationalgrid

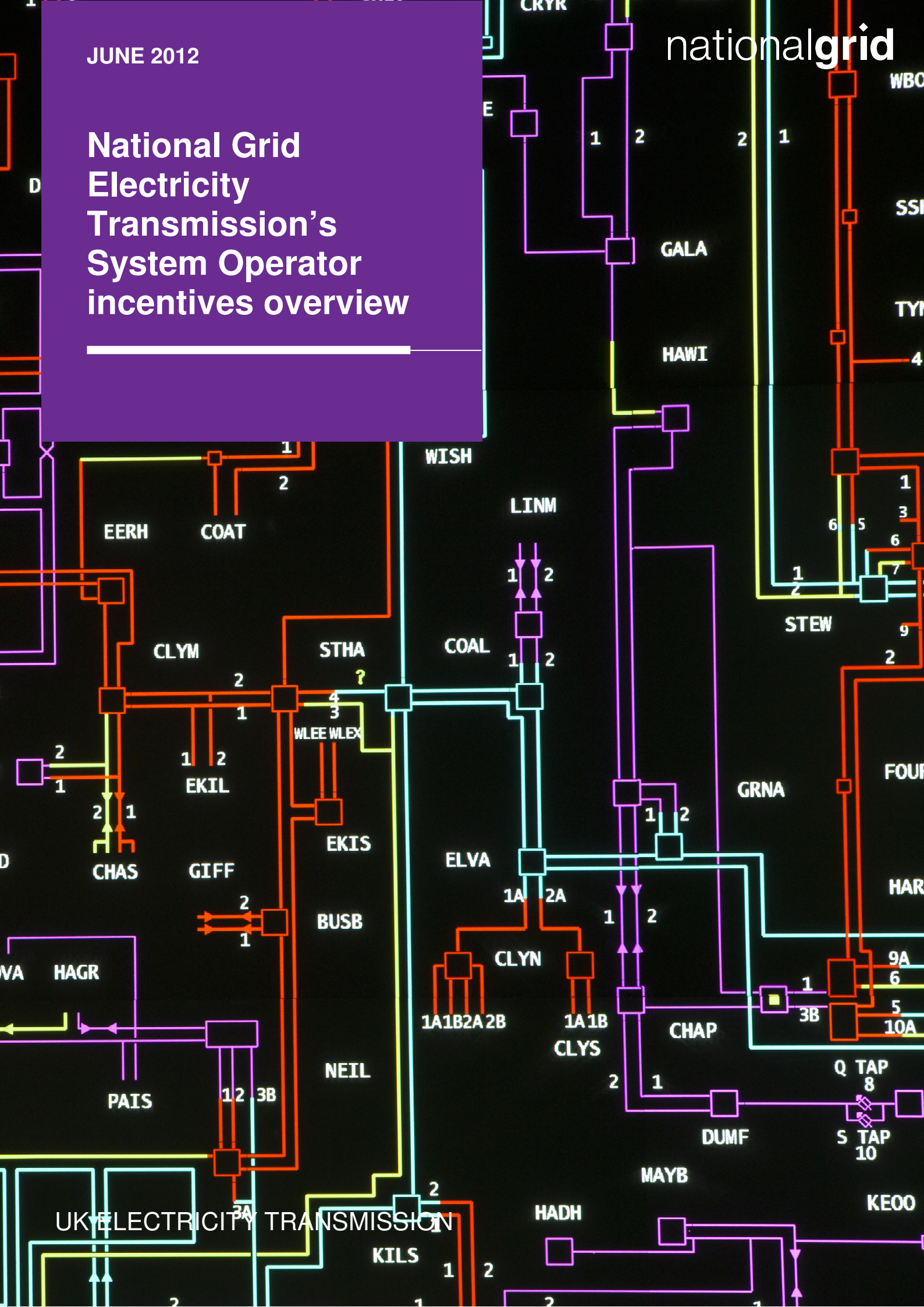

# Introduction

National Grid Electricity Transmission (NGET) undertakes the role of National Electricity Transmission System Operator (NETSO) for England, Wales and Scotland. In parallel to the main gas and electricity transmission RIIO-T1 price control reviews, the incentive framework within which the NETSO operates is also under review. This document summarises NGET's proposed System Operator (SO) incentives framework for the RIIO-T1 period, April 2013 to March 2021, and supplements our main RIIO-T1 business plan, which was submitted to Ofgem in March 2012. This is the first review of the SO activity under the new RIIO regulatory framework model.

## Stakeholder engagement

We have engaged with our stakeholders and sought their views during the development of our SO incentive proposals. These views have been used to shape our plan, and we have included new incentives in the areas that stakeholders have indicated would be of value, in particular around renewable generation forecasting.

The cost of balancing the Great Britain system is expected to rise significantly in the coming years as we transition to a low carbon energy future. The NETSO will play a critical role in minimising these costs on behalf of consumers and our proposals are designed to ensure that a strong incentive is in place to support this objective.

## Our proposals

These proposals have been developed to be consistent with the principles set out in Ofgem's January 2012 consultation, together with the views expressed by ourselves and other stakeholders in response to that consultation<sup>1</sup>.

We are proposing a longer-term incentive framework, where schemes are designed to operate on an annual basis, with annual targets, caps/collars and sharing factors.

Recognising that the eight year period is much longer than for the previous SO incentive scheme framework, we are proposing a number of mechanisms which could reopen the relevant incentive schemes if certain events occur.

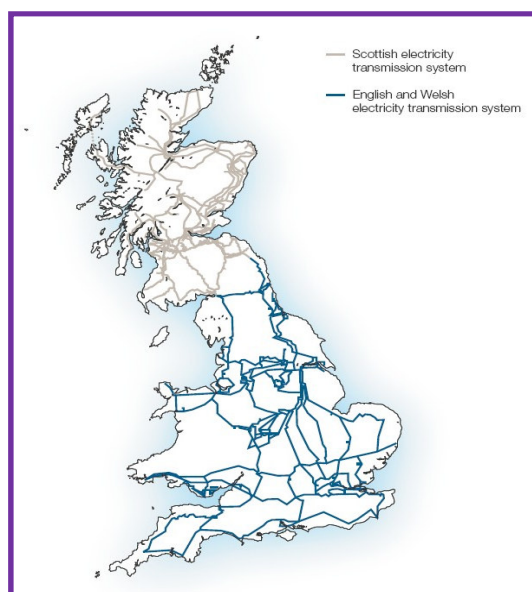

<sup>1</sup> Consultations are available via the Ofgem website, [www.ofgem.gov.uk](http://www.ofgem.gov.uk)

2 NGET SO incentives business plan

**Want to know more about RIIO?**

**Visit**

**[www.ofgem.gov.uk/networks/trans/price-controls/riio-t1/pages/riio-t1.aspx](http://www.ofgem.gov.uk/networks/trans/price-controls/riio-t1/pages/riio-t1.aspx)**



# Summary

Our proposed framework incentivises us to deliver the outputs stakeholders have told us are important to them at the lowest cost to the consumer. For Electricity Transmission, this is primarily minimising the costs of operating the National Electricity Transmission System (NETS).

## What stakeholders told us

We spoke to stakeholders as part of our Talking Networks engagement programme about what they wanted us to deliver. They gave us clear messages for each of the RIIO outputs:

<b>Safety</b>	“Safety is non-negotiable”
<b>Reliability (and availability)</b>	“Reliability must be maintained”
<b>Environment</b>	“Facilitate low carbon energy”
<b>Customer satisfaction</b>	“Improve customer service”
<b>Customer connections</b>	“Process should be developed”

**Want to know more?**  
**Visit**  
[www.talkingnetworkstx.com/electricityplan/our-business-plan.aspx](http://www.talkingnetworkstx.com/electricityplan/our-business-plan.aspx)

## Outputs and incentives

For these outputs, the NETSO’s main influence is in relation to reliability, the environment and customer (stakeholder) satisfaction. For the SO, Ofgem has also proposed two additional outputs – a balanced system (matching supply with demand) and provision of information to the market. To help us meet the outputs, we are proposing the incentives shown below – these will work alongside the Transmission Owner (TO) incentives which were proposed as part of our main RIIO-T1 business plans.

Reliability	Environment	Customer satisfaction	Balanced system	Provision of information
<ul style="list-style-type: none"> <li>• Balancing Services Incentive Scheme (BSIS) covering energy components, constraints, Black Start &amp; Transmission losses</li> <li>• Renewable generation forecasting</li> </ul>	<ul style="list-style-type: none"> <li>• BSIS: Transmission losses</li> </ul>	<ul style="list-style-type: none"> <li>• Customer satisfaction and stakeholder engagement</li> <li>• BSIS: energy components, constraints, Black Start</li> <li>• Renewable generation forecasting</li> </ul>	<ul style="list-style-type: none"> <li>• BSIS: energy components, constraints</li> </ul>	<ul style="list-style-type: none"> <li>• Renewable generation forecasting</li> </ul>

# Our proposed incentives

Under RIIO, we will deliver agreed levels of outputs for safety, reliability and availability, our environmental impact, customer satisfaction, customer connections, providing a balanced system and the provision of information. To incentivise efficient delivery of these outputs by the System Operator, we are proposing a number of SO incentive schemes.

## Balancing Services Incentive Scheme (BSIS)

BSIS is designed to deliver financial benefits to the industry and consumers by minimising the costs of operating the NETS.

The scheme consists of a number of individual components which are combined under one incentive scheme. All of these components are subject to the parameters shown to the right, which are applied annually. The sharing factor is the percentage of external costs to which the NETSO is exposed.

	Annual National Grid sharing factor	Annual cap/collar post sharing factor
April 2013-March 2015	30%	± £30m
April 2015-March 2017	40%	± £40m
April 2017-March 2021	50%	± £50m

## Elements of BSIS

An overview of the incentive schemes of which BSIS comprises is shown below, with more details on the following page.

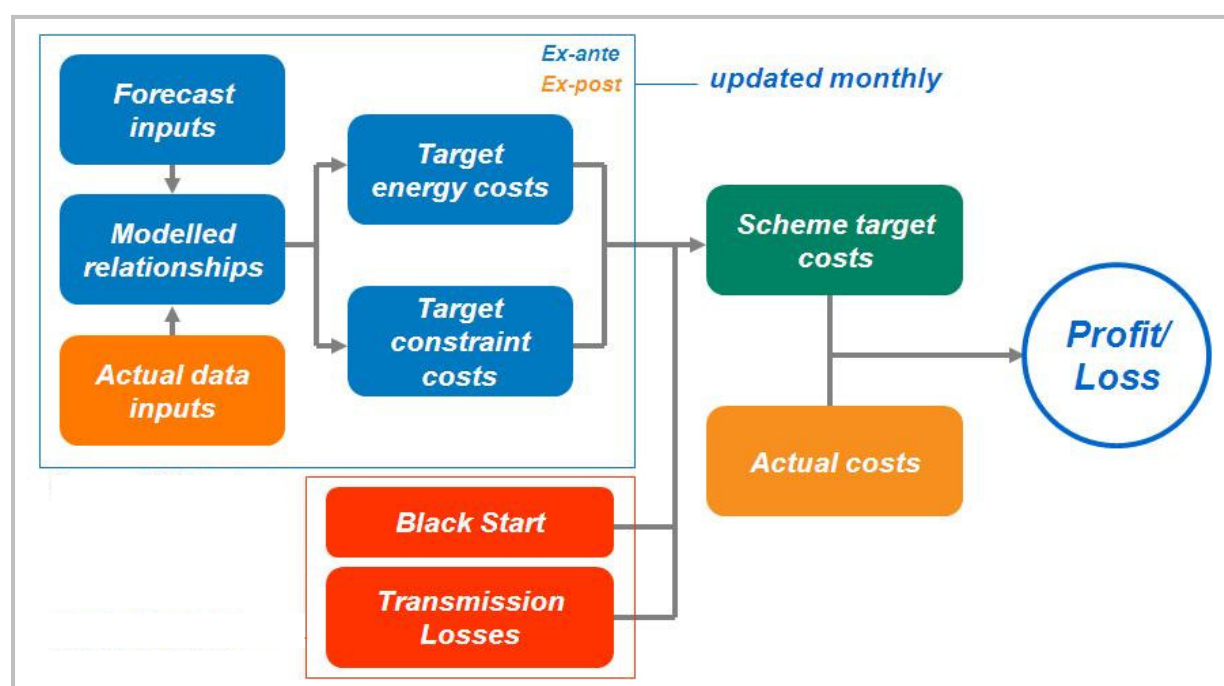

### The components of BSIS:

<b>Energy components</b>	<ul style="list-style-type: none"> <li>• Incentive based on a modelled cost target which represents the drivers of operating costs over the RIIO-T1 period, including the costs of reserve and response, energy balancing and reactive power</li> <li>• Includes a review and subsequent reassessment of the ex ante or ex post treatment of model inputs</li> <li>• Proposals to further review and develop the suite of models over the 8 year period</li> </ul>
<b>Constraints</b>	<ul style="list-style-type: none"> <li>• Incentive based on actual costs versus modelled costs from a constraint costs forecasting model</li> <li>• The model has been enhanced to more accurately represent developments to the NETS over the RIIO-T1 period, building on lessons learnt from the 2011-13 scheme</li> <li>• Includes a review and subsequent reassessment of the ex ante or ex post treatment of model inputs</li> <li>• New uplift factor applied to target model output to account for modelling shortfalls</li> <li>• Includes a proposal to align the NETSO and TO incentives for constraint costs associated with networks outside of England and Wales</li> </ul>
<b>Black Start</b>	<ul style="list-style-type: none"> <li>• Incentive based on cost target derived from a number of assumptions for both new and existing Black Start provider costs</li> <li>• Includes annualised new entrant cost assumption with downward adjustment for legacy contracts</li> <li>• Ex ante allowance for annual feasibility studies and testing costs</li> </ul>
<b>Transmission losses</b>	<ul style="list-style-type: none"> <li>• Incentive based on an ex ante volume target based on previous year outturn with ex post adjustment</li> <li>• 20% National Grid sharing factor, which is applied in addition to the overarching BSIS sharing factor</li> </ul>

### Other proposed incentives:

<b>Renewable generation forecasting</b>	<ul style="list-style-type: none"> <li>• A new financial incentive to reduce day-ahead wind forecasting error</li> <li>• Introduction of regional forecasts and an increase to 4 national forecasts per day</li> <li>• A cap/collar of +/-£250k per month</li> <li>• 4+4 year scheme, with a mid-point review</li> </ul>
<b>Customer satisfaction / stakeholder engagement</b>	<ul style="list-style-type: none"> <li>• Our proposed RIIO-T1 customer satisfaction incentive will include the SO role</li> <li>• Up to +/-1% of annual TO revenue and an additional stakeholder engagement incentive of up to 0.5% of annual TO revenue</li> <li>• Full details of this scheme can be found in our main RIIO-T1 business plan</li> </ul>

**Want to know more?**  
**View our full SO incentives proposals at**  
[www.nationalgrid.com/uk/Electricity/soincentives/docs/](http://www.nationalgrid.com/uk/Electricity/soincentives/docs/)



# Managing uncertainty and risk

In light of the uncertainty associated with an eight year incentive period and the possible level of change compared to our forecasts, we are proposing incentives which are sufficiently flexible to accommodate market developments over the RIIO-T1 period.

## Dealing with uncertainty

Where incentives are new, or where incentive targets could become inaccurate over a longer timeframe given the uncertainties we face, we have proposed that incentive methodologies and targets are reviewed periodically through the available governance routes to ensure they remain focused on the outputs valued by stakeholders.

We have sought to align sharing factors with those set out under our main RIIO-T1 plans. We have retained the use of caps and collars where appropriate, to protect ourselves and consumers against gains or losses resulting from factors outside of our control. We also propose to retain the concept of Income Adjusting Events to manage unforeseen, low probability but high impact events.

In addition, our proposed incentive schemes include a number of mechanisms to deal with uncertainty. These mechanisms will be triggered by significant policy changes. If they are triggered, it may be necessary to reopen the related schemes.

Our key drivers of uncertainty include:

<b>Market price risk</b>	Principally driven by fuel input costs and generation capacity limitations
<b>Volume risk</b>	Driven by factors such as demand and supply mismatches and the volume of constraints on the system
<b>Political/regulatory developments</b>	For example, Electricity Market Reform or European Network Code reviews
<b>Operating environment</b>	One-off events such as floods and storms

## Managing risk

Our proposed incentives are designed to provide financial reward for delivery over and above the baseline level set by the incentive targets, and a financial penalty for under performance. However, an element of residual risk remains which is outside of our direct control. We are proposing an annual £7.7m premium to finance this risk.

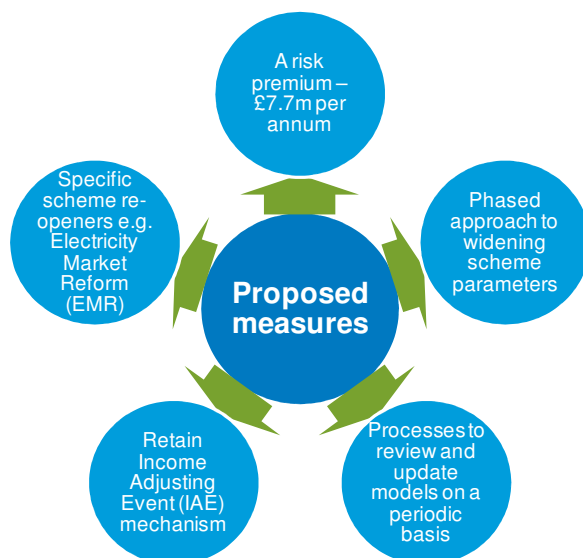

We have maintained the principle that risk should be borne by the party best placed to manage it – the schemes proposed in our plan aim to represent a fair balance of risk and reward and operate in the interests of consumers.

**Want to know more?**  
View our SO incentives plan at  
[www.nationalgrid.com/uk/Electricity/soincentives/docs/](http://www.nationalgrid.com/uk/Electricity/soincentives/docs/)

# Finance / next steps

## Returns on equity

Given the relatively small size of the SO's Regulatory Asset Value (RAV) we have combined the SO and Transmission Owner (TO) returns. As combined SO and TO, our potential return on regulated equity (RORE) could be between 3.5% and 11.0% (real) – these figures have been updated since our main RIIO-T1 submission in March 2012 to include our SO incentive returns.

The chart to the right illustrates the plausible RORE range using a 50% efficiency rate.

## RORE Analysis: Electricity Transmission

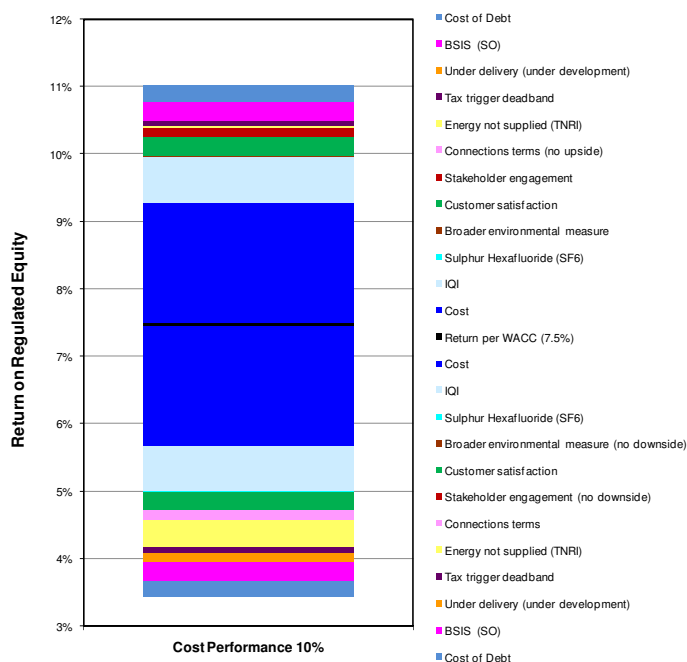

**Want to know more?**  
**Refer to our RIIO-T1 'Finance' annex at**  
[www.talkingnetworkstx.com/electricityplan/our-business-plan.aspx](http://www.talkingnetworkstx.com/electricityplan/our-business-plan.aspx)

## Next steps



For more information and our full plan see  
[www.nationalgrid.com/uk/Electricity/soincentives/docs/](http://www.nationalgrid.com/uk/Electricity/soincentives/docs/)

For further information contact  
Peter Bingham  
Head of SO Incentives & Industry Frameworks  
National Grid House, Warwick, CV34 6DA  
01926 655568  
[talkingnetworkstransmission@uk.ngrid.com](mailto:talkingnetworkstransmission@uk.ngrid.com)