

Public

Data Sharing Infrastructure Pilot

**An enabler of the
Virtual Energy System**

Jonathan Barcroft

What Is The Virtual Energy System?

Creating the **common data sharing infrastructure**.

Enabling an ecosystem of **connected digital twins**.

Facilitating the transition to net zero.

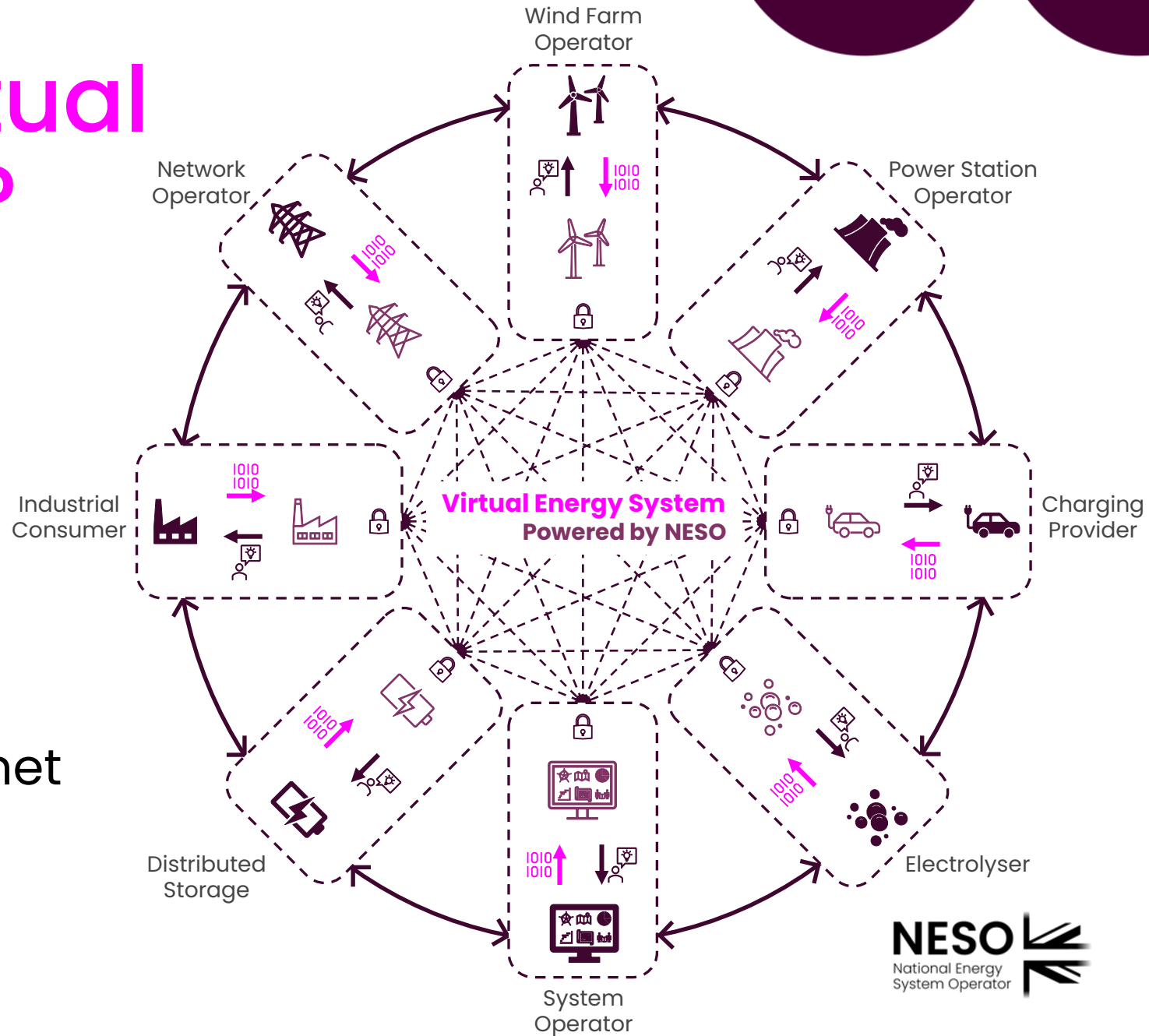

How Has The Concept Developed?

Discovery

- Explored potential use cases, users, high level problem and global best practice

Alpha

- Defined implementation roadmap, user journeys, data products and high-level design

Private Beta

- Development of the Pilot and MVP

Research has defined the need:



2022: Energy Digitalisation Taskforce recommended the Digital Spine and Data Sharing Fabric



2023: Future System Network Regulation and Distributed Flex consultations recommend Data Sharing Infrastructure.



2024: Digital Spine Feasibility Study recommendations published

Project Partners



and Network Partners



Pilot Use Case

Operational Planning Pilot Use Case

Explore data exchange between DSOs, TOs, and NESO to support coordination of operational planning

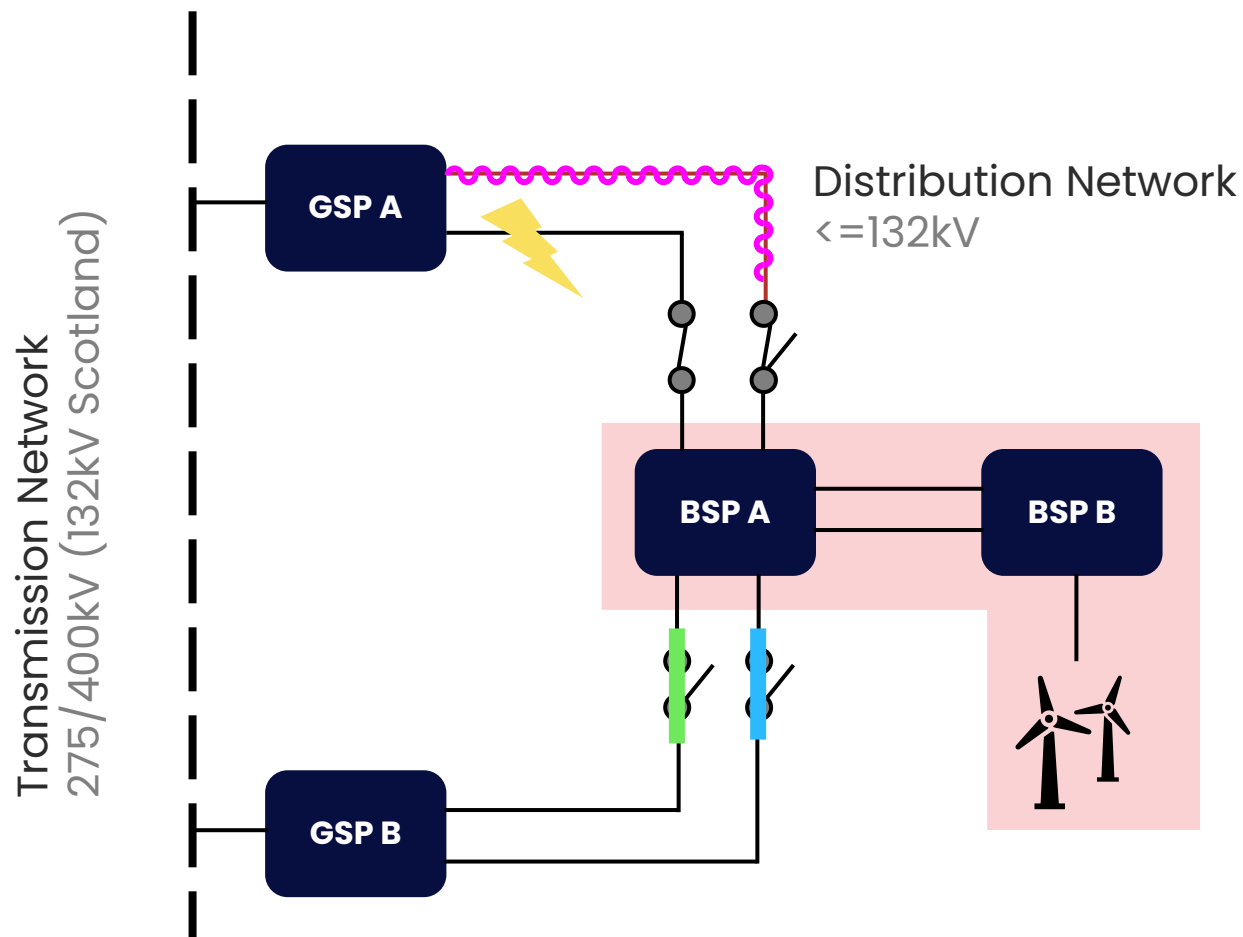

What Are The Opportunities?



Reduce rework and manual data processing



Identify and reduce risk and costs on the system



Better situational awareness for neighbouring users



Develop and evolve further modelling capabilities



Data Sharing Infrastructure

Data Preparation Node (DPN)

A containerised application for deployment by organisations in their own infrastructure.



Interfaces to organisational data sources and destinations



Label data with security tags and perform schema assurance



Metadata for sharing data catalogue of available sources



Interface for data exchange and data sharing mechanism communication

Data Sharing Mechanism (DSM)

A control plane for the security and governance to facilitate data exchange between nodes.



Security and organisational identity services



Trust services to establish user's confidence, right & legality to share data



Data catalogue for discovery and definition of data available



Node management to support deployment and registration

Data Sharing Interactions

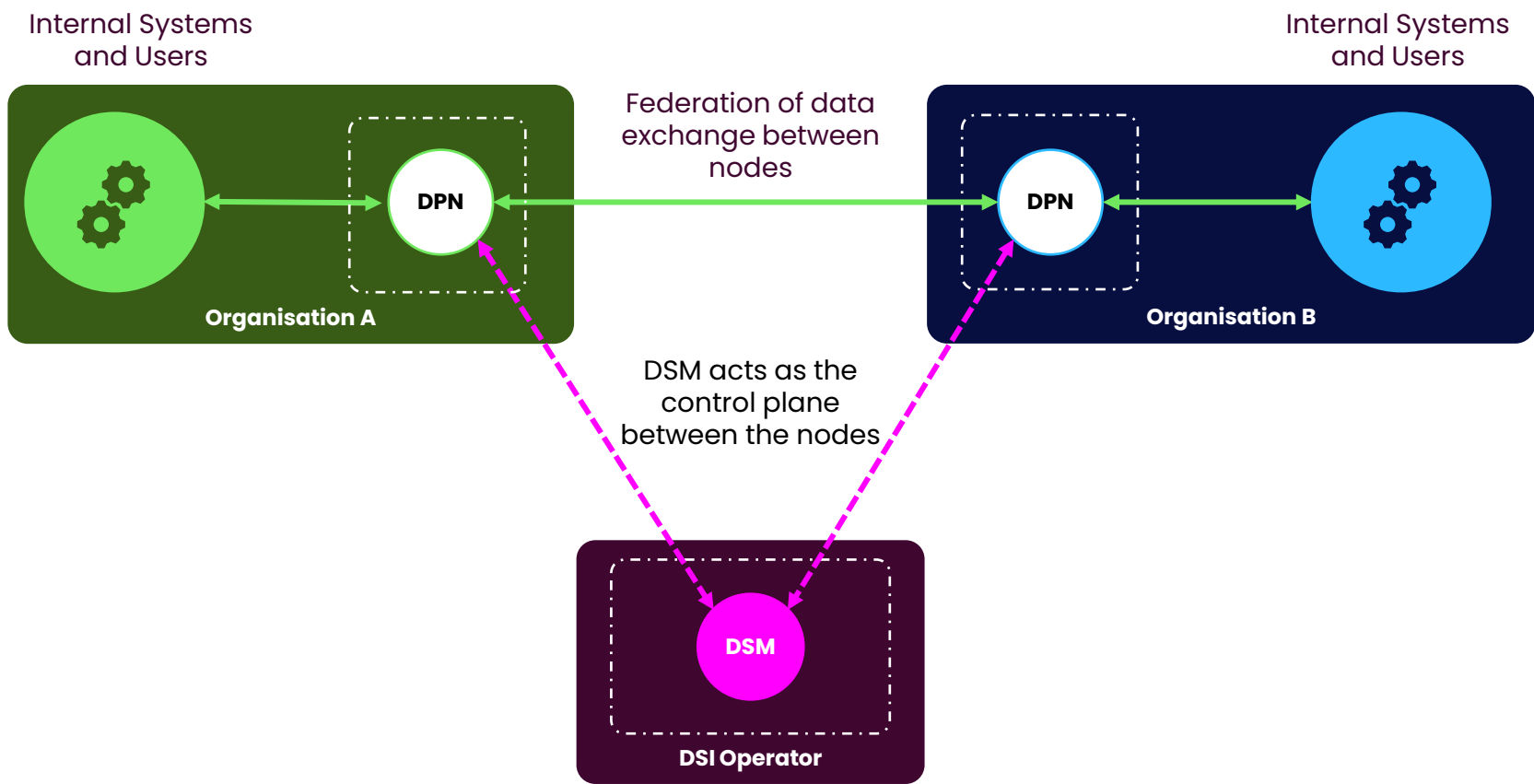

Pilot Implementation

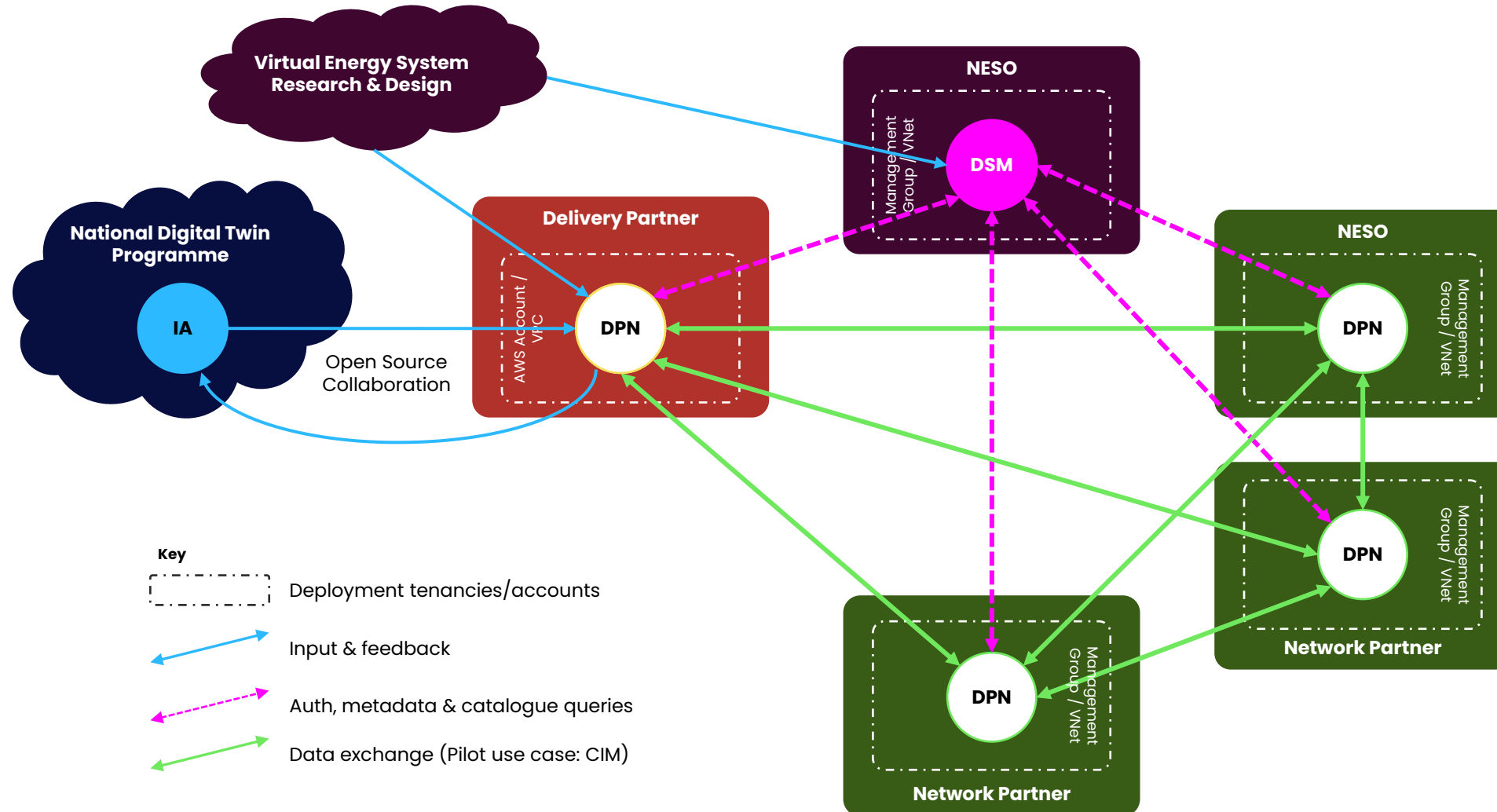

High Level Roadmap

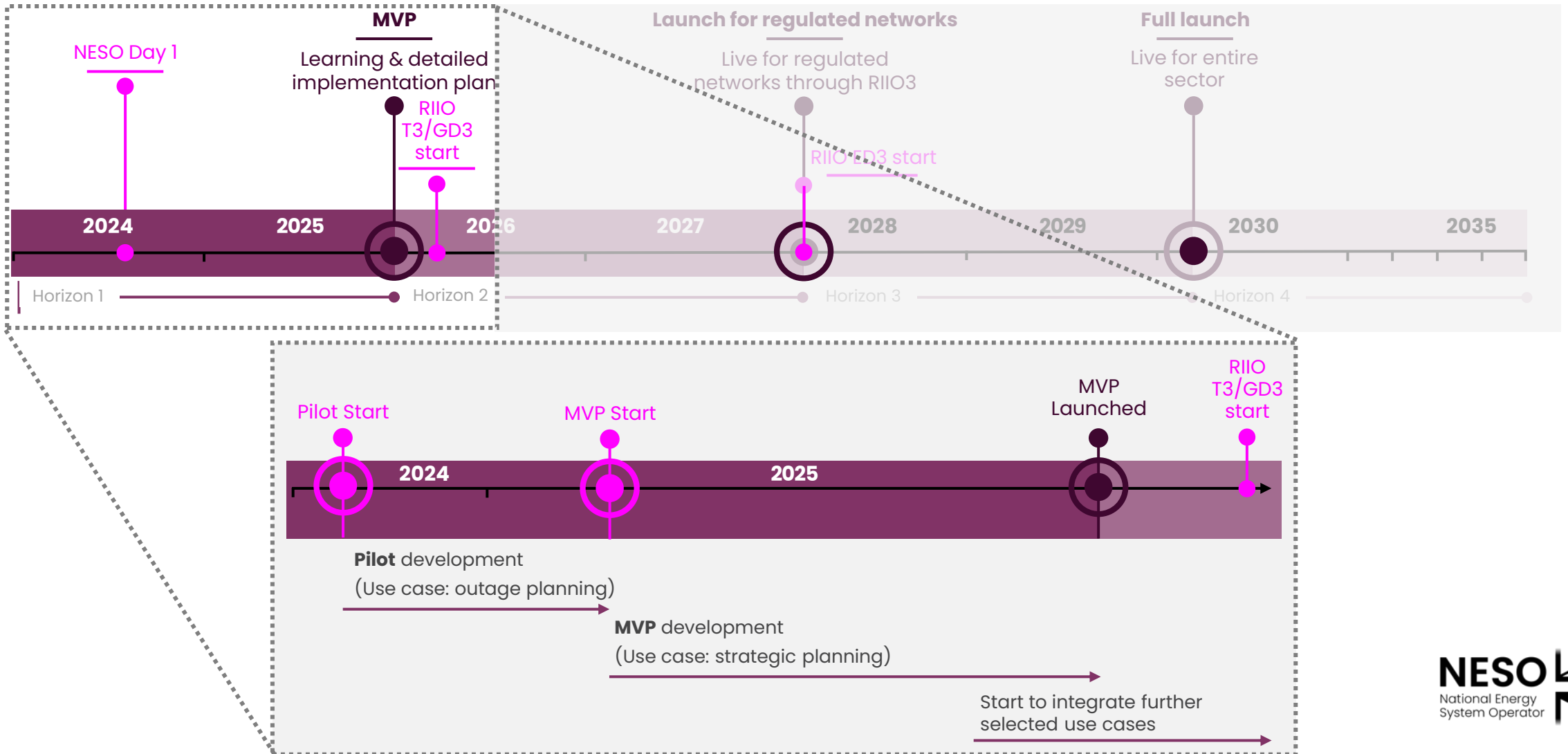

Find out more:

VirtualES@nationalenergyso.com

www.neso.energy