

**fPLANNING CODE**

(PC)

Formatted: Left

**CONTENTS**

(This contents page does not form part of the Grid Code)

<u>Paragraph No/Title</u>	<u>Page Number</u>
PC.1 INTRODUCTION.....	2
PC.2 OBJECTIVE.....	3
PC.3 SCOPE.....	4
PC.4 PLANNING PROCEDURES.....	87
PC.5 PLANNING DATA.....	111119
PC.6 PLANNING STANDARDS.....	141418
PC.7 PLANNING LIAISON.....	151514
PC.8 OTSDUW PLANNING LIAISON.....	161615
<u>PC.9 SUBMISSION OF SYSTEM MODELS AND INFORMATION BY NETWORK OPERATORS TO THE COMPANY.....</u>	<u>17</u>
<u>PC.10 SUBMISSION OF SYSTEM MODELS AND INFORMATION BY THE COMPANY TO NETWORK OPERATORS.....</u>	<u>27</u>
APPENDIX A - PLANNING DATA REQUIREMENTS.....	353416
PART 1 - STANDARD PLANNING DATA.....	393829
PC.A.2 USER'S SYSTEM (AND OTSUA) DATA.....	393829
PC.A.3 GENERATING UNIT AND DC CONVERTER DATA.....	484729
PC.A.4 DEMAND AND ACTIVE ENERGY DATA.....	575638
PART 2 - DETAILED PLANNING DATA.....	646344
PC.A.5 GENERATING UNIT, POWER PARK MODULE, DC CONVERTER AND OTSDUW PLANT AND APPARATUS DATA.....	646344
PC.A.6 USERS' SYSTEM DATA.....	878667
PC.A.7 ADDITIONAL DATA FOR NEW TYPES OF POWER STATIONS, DC CONVERTER STATIONS, OTSUA AND CONFIGURATIONS.....	929172
PART 3 - DETAILED PLANNING DATA.....	939273
APPENDIX B - SINGLE LINE DIAGRAMS.....	10240182
APPENDIX C - TECHNICAL AND DESIGN CRITERIA.....	10510485
PART 1 - SHETL's TECHNICAL AND DESIGN CRITERIA.....	10510485
PART 2 - SPT's TECHNICAL AND DESIGN CRITERIA.....	10740687
APPENDIX D - DATA NOT DISCLOSED TO A RELEVANT TRANSMISSION LICENSEE.....	10840788
APPENDIX E - OFFSHORE TRANSMISSION SYSTEM AND OTSDUW PLANT AND APPARATUS TECHNICAL AND DESIGN CRITERIA.....	11141091
APPENDIX F - OTSDUW DATA AND INFORMATION AND OTSDUW NETWORK DATA AND INFORMATION.....	11241192
<u>APPENDIX G - NETWORK OPERATOR AND THE COMPANY PLANNING DATA EXCHANGE.....</u>	<u>118</u>

Formatted: Check spelling and grammar

PC.1 INTRODUCTION

PC.1.1 The **Planning Code ("PC")** specifies the technical and design criteria and procedures to be applied by **The Company** in the planning and development of the **National Electricity Transmission System** and to be taken into account by **Users** in the planning and development of their own **Systems**. In the case of **OTSUA**, the **PC** also specifies the technical and design criteria and procedures to be applied by the **User** in the planning and development of the **OTSUA**. It details information to be supplied by **Users to The Company**, and certain information to be supplied by **The Company to Users**. **The Company** has obligations under the **STC** to inform **Relevant Transmission Licensees** of data required for the planning of the **National Electricity Transmission System**. In respect of **PC** data, **The Company** may pass on **User** data to a **Relevant Transmission Licensee**, as detailed in PC.3.4 and PC.3.5.

PC.1.1A Provisions of the **PC** which apply in relation to **OTSDUW** and **OTSUA** shall apply up to the **OTSUA Transfer Time**, whereupon such provisions shall (without prejudice to any prior non-compliance) cease to apply, without prejudice to the continuing application of provisions of the **PC** applying in relation to the relevant **Offshore Transmission System** and/or **Connection Site**.

PC.1.1B As used in the **PC**:

- (a) **National Electricity Transmission System** excludes **OTSDUW Plant and Apparatus** (prior to the **OTSUA Transfer Time**) unless the context otherwise requires;
- (b) and **User Development** includes **OTSDUW** unless the context otherwise requires.

PC.1.2 The **Users** referred to above are defined, for the purpose of the **PC**, in PC.3.1.

PC.1.3 Development of the **National Electricity Transmission System**, involving its reinforcement or extension, will arise for a number of reasons including, but not limited to:

- (a) a development on a **User System** already connected to the **National Electricity Transmission System**;
- (b) the introduction of a new **Connection Site** or the **Modification** of an existing **Connection Site** between a **User System** and the **National Electricity Transmission System**;
- (c) the cumulative effect of a number of such developments referred to in (a) and (b) by one or more **Users**.

PC.1.4 Accordingly, the reinforcement or extension of the **National Electricity Transmission System** may involve work:

- (a) at a substation at a **Connection Site** where **User's Plant** and/or **Apparatus** is connected to the **National Electricity Transmission System** (or in the case of **OTSDUW**, at a substation at an **Interface Point**);
- (b) on transmission lines or other facilities which join that **Connection Site** (or in the case of **OTSDUW**, **Interface Point**) to the remainder of the **National Electricity Transmission System**;
- (c) on transmission lines or other facilities at or between points remote from that **Connection Site** (or in the case of **OTSDUW**, **Interface Point**).

Commented [AC1]: Defined term - bold

Commented [PT(2R1)]: Sub-group Accept

PC.1.5 The time required for the planning and development of the **National Electricity Transmission System** will depend on the type and extent of the necessary reinforcement and/or extension work, the need or otherwise for statutory planning consent, the associated possibility of the need for a public inquiry and the degree of complexity in undertaking the new work while maintaining satisfactory security and quality of supply on the existing **National Electricity Transmission System**.

PC1.6 For the avoidance of doubt and the purposes of the Grid Code, **DC Connected Power Park Modules** are treated as belonging to **Generators**. **Generators** who own **DC Connected Power Park Modules** would therefore be expected to supply the same data as required under this **PC** in respect of **Power Stations** comprising **Power Park Modules** other than where specific references to **DC Connected Power Park Modules** are made.

PC1.7 As defined in the Glossary and Definitions, **Electricity Storage Modules** are treated as belonging to **Storage Users** who are a subset of **Generators**. **Generators** who own or operate **Electricity Storage Modules** would therefore be expected to supply the same data as required under this **PC** in respect of **Power Stations**. In general, and notwithstanding the requirements in respect of the Glossary and Definitions and the wider requirements specified in the **Planning Code**, **Generators** in respect of **Synchronous Electricity Storage Modules** would be expected to supply the same data as required from **Generators** in respect of **Synchronous Power Generating Modules** and **Generators** in respect of **Non-Synchronous Electricity Storage Modules** would be expected to supply the same data as required from **Generators** in respect of **Power Park Modules**.

- Commented [VG3]: Should this be Users?
- Commented [AC4]: unbold
- Commented [PT(5R4)]: Sub-group Accept
- Commented [AC6]: Bold for consistency
- Commented [PT(7R6)]: Sub-group Accept
- Commented [AC8]: What does this mean?
- Commented [AC9]: unbold
- Commented [PT(10R9)]: Sub-group Accept

PC.2 OBJECTIVE

PC.2.1 The objectives of the **PC** are:

- (a) to promote **The Company/User** interaction in respect of any proposed development on the **User System** which may impact on the performance of the **National Electricity Transmission System** or the direct connection with the **National Electricity Transmission System**;
- (b) to provide for the supply of information to **The Company** from **Users** in order that planning and development of the **National Electricity Transmission System** can be undertaken in accordance with the relevant **Licence Standards**, to facilitate existing and proposed connections, and also to provide for the supply of certain information from **The Company** to **Users** in order that planning relation to short circuit current contributions and development of the **User's System** can be undertaken in accordance with their relevant **Licence Standards**; and
- (c) to specify the **Licence Standards** which will be used in the planning and development of the **National Electricity Transmission System**; and
- (d) to provide for the supply of information required by **The Company** from **Users** in respect of the following to enable **The Company** to carry out its duties under the **Act** and the **Transmission Licence**:
  - (i) **Mothballed Generating Units**, **Mothballed Power Generating Modules**; and
  - (ii) capability of gas-fired **Synchronous Power Generating Modules** or **Generating Units** to run using alternative fuels.

- Commented [AC11]: ...of relevant information....
- Commented [AC12]: Licence Standard, as a define dem doesn't refer to Users.  
Suggest:  
...development of the **User's System** can be undertaken in accordance with their regulatory requirements; and
- Commented [AC13]: unbold
- Commented [PT(14R13)]: Sub-group Accept

**The Company** will use the information provided under PC.2.1(d) in providing reports to the **Authority** and the **Secretary of State** and, where directed by the **Authority** or the **Secretary of State** to do so, **The Company** may publish the information. Where it is known by **The Company** that such information is intended for wider publication the information provided under PC.2.1(d) shall be aggregated such that individual data items should not be identifiable.

- (e) in the case of **OTSUA**:
  - (i) to specify the minimum technical and design criteria and procedures to be applied by **Users** in the planning and development of **OTSUA**; and thereby
  - (ii) to ensure that the **OTSUA** can from the **OTSUA Transfer Time** be operated as part of the **National Electricity Transmission System**; and
  - (iii) to provide for the arrangements and supply of information and data between **The Company** and a **User** to ensure that the **User** is able to undertake **OTSDUW**; and
  - (iv) to promote **The Company/User** interaction and co-ordination in respect of any proposed development on the **National Electricity Transmission System** or the **OTSUA**, which may impact on the **OTSUA** or (as the case may be) the **National Electricity Transmission System**.

PC.3 SCOPE

PC.3.1 The **PC** applies to **The Company** and to **Users**, which in the **PC** means:

- (a) **Generators**;
- (b) **Generators** undertaking **OTSDUW**;
- (c) **Network Operators**;
- (d) **Non-Embedded Customers**;
- (e) **DC Converter Station** owners; and
- (f) **HVDC System Owners**.

The above categories of **User** will become bound by the **PC** prior to them generating, operating, or consuming or importing/exporting, as the case may be, and references to the various categories (or to the general category) of **User** should, therefore, be taken as referring to them in that prospective role as well as to **Users** actually connected.

- PC.3.1.1 Exchanges between **The Company** and the **Network Operators**
- PC.3.1.1.1 From the **PSM Implementation Date** in relation to information exchanges between **The Company** and **Network Operators**, clauses **PC.3.3, PC.3.4, PC.3.5, PC.3.6, PC3.7, PC.4.2.5, PC.4.3, PC.4.4.1(b), PC.4.5** and **PC.A** shall not apply and clauses **PC.9, PC.10** and **PC.G** shall apply.
- PC.3.1.1.2 In the event that **The Company** and all **Network Operators** are not in a position to implement data exchange as described in **PC.9, PC.10** and **PC.G**, by **PSM Implementation Date**, **The Company** and **Network Operators** shall use their best endeavors to agree an alternative **PSM Implementation Date**.
- PC.3.1.1.3 Nothing shall prevent **The Company** and **Network Operators** from progressing to the new information exchange method before the **PSM Implementation Date**, subject to unanimous written approval of **The Company** and all **Network Operators**.
- PC.3.1.1.4 The **PSM** data exchanges shall conform to the data exchange profile standards and satisfy the implementation requirements outlined in **PC.G.4.1**. **Alternative versions and/or appropriate extensions** may be used as agreed between **The Company** and all the **Network Operators** or as directed by the **GB CIM Governance Group**, as described in **PC.G. 4.3**, and agreed by **The Company** and all the **Network Operators**.

Commented [AC15]: ...and Network Operators

Commented [RS16]: So does this mean that Schedule 5/ diagrams would cease to be required from the PSM implementation date? (whenever that is)

Commented [RS17R16]: Currently specified as 1<sup>st</sup> January 2026 according to the implementation date

Commented [PT(18)]: PC.7 to added here

Commented [AC19]: Delete superfluous space

Commented [PT(20R19)]: Sub-group Accept

Formatted: Highlight

Commented [AC21]: ..by the PSM....

Commented [PT(22R21)]: Sub-group Accept

Formatted: Highlight

Formatted: Highlight

Formatted: Highlight

Formatted: Highlight

Commented [AC23]: Alternative exchange profile standards and/or .....

PC.3.1.1.5 The **Structural Data** in the exchanged **PSMs** shall utilise unique and persistent identifiers. An identifier shall be assigned to each grid component in the **Structural Data** which shall be unique and persist throughout the life of the

PC.3.1.1.6 The omission of data not yet supported by the data exchange standard identified in PC.G.4 will not be seen as non-compliance.

PC.3.2 In the case of **Embedded Power Stations**, **Embedded DC Converter Stations** and **Embedded HVDC Systems**, unless provided otherwise, the following provisions apply with regard to the provision of data under this **PC**:

- (a) each **Generator** shall provide the data direct to **The Company** in respect of (i) **Embedded Large Power Stations**, (ii) **Embedded Medium Power Stations** subject to a **Bilateral Agreement** and (iii) **Embedded Small Power Stations** which form part of a **Cascade Hydro Scheme**;
- (b) each **DC Converter** owner or **HVDC System Owner** shall provide the data direct to **The Company** in respect of **Embedded DC Converter Stations** and **Embedded HVDC Systems** subject to a **Bilateral Agreement**;
- (c) each **Network Operator** shall provide the data to **The Company** in respect of each **Embedded Medium Power Station** not subject to a **Bilateral Agreement** or **Embedded DC Converter Station** not subject to a **Bilateral Agreement** or **Embedded HVDC System** not subject to a **Bilateral Agreement** connected, or proposed to be connected within such **Network Operator's System**;
- (d) although data is not normally required specifically on **Embedded Small Power Stations** or on **Embedded** installations of direct current converters which do not form a **DC Converter Station** or **HVDC System** under this **PC**, each **Network Operator** in whose **System** they are **Embedded** should provide the data (contained in the Appendix) to **The Company** in respect of **Embedded Small Power Stations** or **Embedded** installations of direct current converters which do not form a **DC Converter Station** or **Embedded** installations of **HVDC Systems** if:
  - (i) it falls to be supplied pursuant to the application for a **CUSC Contract** or in the **Statement of Readiness** to be supplied in connection with a **Bilateral Agreement** and/or **Construction Agreement**, by the **Network Operator**; or
  - (ii) it is specifically requested by **The Company** in the circumstances provided for under this **PC**.

PC.3.3 Certain data does not normally need to be provided in respect of certain **Embedded Power Stations**, **Embedded DC Converter Stations** or **Embedded HVDC Systems**, as provided in PC.A.1.12.

In summary, **Network Operators** are required to supply the data described in the following **Planning Code Appendices** data **Appendices** data in respect of **Embedded Medium Power Stations** not subject to a **Bilateral Agreement** or **Embedded DC Converter Stations** not subject to a **Bilateral Agreement** or **Embedded HVDC Systems** not subject to a **Bilateral Agreement** connected, or is proposed to be connected, within such **Network Operator's System**:

- PC.A.2.1.1
- PC.A.2.2.2
- PC.A.2.5.5.2
- PC.A.2.5.5.7
- PC.A.2.5.6
- PC.A.3.1.5
- PC.A.3.2.2
- PC.A.3.3.1

Commented [VG24]: some words missing from the end of this sentence.

Commented [SM(25R24)]: Subgroup suggests has reworded the sentence

Commented [AC26]: ..of the grid component.

Commented [PT(27R26)]: Sub-group Accept

Commented [VG28]: some words missing from the end of this sentence.

Commented [SM29]: Subgroup Proposes "An identifier shall be assigned to the role of each grid component in the **Structural Data** which shall be unique and persist throughout the life of that role."

Commented [AC30]: The omission of data not yet supported by the data exchange standard identified in PC.G.4, from a data exchange, will not be seen as non-compliance.

Commented [AC31]: I wonder if this is required or if its been superceeded by PC9. PC3.3 (which becomes redudant) seems to replicate this

Commented [AC32R31]: PC3.2 won't apply post CIM

Commented [AC33]: Ditto

Commented [AC34]: I wonder which one

- PC.A.3.4.1
- PC.A.3.4.2
- PC.A.5.2.2
- PC.A.5.3.2
- PC.A.5.4
- PC.A.5.5.1
- PC.A.5.6

For the avoidance of doubt **Network Operators** are required to supply the above data in respect of **Embedded Medium Power Stations** not subject to a **Bilateral Agreement** and **Embedded DC Converter Stations** not subject to a **Bilateral Agreement** and **Embedded HVDC Systems** not subject to a **Bilateral Agreement** which are located **Offshore** and which are connected or proposed to be connected within such **Network Operator's System**. This is because **Embedded Medium Power Stations** not subject to a **Bilateral Agreement** and **Embedded DC Converter Stations** not subject to a **Bilateral Agreement** and **Embedded HVDC Systems** not subject to a **Bilateral Agreement** are treated as **Onshore Generators** or **Onshore DC Converter Station** owners or **HVDC System Owners** connected to an **Onshore User System Entry Point**.

PC.3.4 **The Company** may provide to the **Relevant Transmission Licensees** any data which has been submitted to **The Company** by any **Users** pursuant to the following paragraphs of the **PC**. For the avoidance of doubt, **The Company** will not provide to the **Relevant Transmission Licensees**, the types of data specified in Appendix D. The **Relevant Transmission Licensees'** use of such data is detailed in the **STC**.

- PC.A.2.2
- PC.A.2.5
- PC.A.3.1
- PC.A.3.2.1
- PC.A.3.2.2
- PC.A.3.3
- PC.A.3.4
- PC.A.4
- PC.A.5.1
- PC.A.5.2
- PC.A.5.3.1
- PC.A.5.3.2
- PC.A.5.4.1
- PC.A.5.4.2
- PC.A.5.4.3.1
- PC.A.5.4.3.2
- PC.A.5.4.3.3
- PC.A.5.4.3.4
- PC.A.7

(and in addition in respect of the data submitted in respect of the **OTSUA**)

- PC.A.2.2
- PC.A.2.3

- PC.A.2.4
- PC.A.2.5
- PC.A.3.2.2
- PC.A.3.3.1(d)
- PC.A.4
- PC.A.5.4.3.1
- PC.A.5.4.3.2
- PC.A.6.2
- PC.A.6.3
- PC.A.6.4
- PC.A.6.5
- PC.A.6.6
- PC.A.7

PC.3.5 In addition to the provisions of PC.3.4, **The Company** may provide to the **Relevant Transmission Licensees** any data which has been submitted to **The Company** by any **Users** in respect of **Relevant Units** pursuant to the following paragraphs of the **PC**.

- PC.A.2.3
- PC.A.2.4
- PC.A.5.5
- PC.A.5.7
- PC.A.6.2
- PC.A.6.3
- PC.A.6.4
- PC.A.6.5
- PC.A.6.6

PC.3.6 In the case of **Offshore Embedded Power Stations** connected to an **Offshore User System** which directly connects to an **Offshore Transmission System**, any additional data requirements in respect of such **Offshore Embedded Power Stations** may be specified in the relevant **Bilateral Agreement** with the **Network Operator** or in any **Bilateral Agreement** between **The Company** and such **Offshore Embedded Power Station**.

PC.3.7 In the case of a **Generator** undertaking **OTSDUW** connecting to an **Onshore Network Operator's System**, any additional requirements in respect of such **OTSDUW Plant and Apparatus** will be specified in the relevant **Bilateral Agreement** with the **Generator**. For the avoidance of doubt, requirements applicable to **Generators** undertaking **OTSDUW** and connecting to a **Network Operator's User System**, shall be consistent with those applicable requirements of **Generators** undertaking **OTSDUW** and connecting to a **Transmission Interface Point**.

PC.3.8 For the purpose of complying with the requirements of ECC.6.3.17.1.5 and ECC.6.3.17.2.3 **The Company** may share relevant modelling information to a **User** based on the following information submitted by a **User** to **The Company**:

- PC.A.5.3.2(a), (b), (c), (d) and (g)
- PC.A.5.4.2
- PC.A.5.4.3
- PC.A.9

Commented [AC35]: ...with a ...

Commented [PT(36R35)]: Sub-group Accept  
Delete .

PC.3.9 A **User** who receives information from **The Company** under PC.3.8 may only use the information to complete the analysis required by ECC.6.3.17.1 and EEC.6.3.17.2 as applicable and the **Bilateral Agreement**. Further conditions on the sharing of models are detailed in PC.A.9

Commented [AC37]: unbold

Commented [PT(38R37)]: Sub-group Accept

PC.4 **PLANNING PROCEDURES**

PC.4.1 Pursuant to Condition C11 of **The Company's Transmission Licence**, the means by which **Users** and proposed **Users** of the **National Electricity Transmission System** are able to assess opportunities for connecting to, and using, the **National Electricity Transmission System** comprise two distinct parts, namely:

- (a) a statement, prepared by **The Company** under its **Transmission Licence**, showing for each of the seven succeeding **Financial Years**, the opportunities available for connecting to and using the **National Electricity Transmission System** and indicating those parts of the **National Electricity Transmission System** most suited to new connections and transport of further quantities of electricity (the "**Seven Year Statement**"); and
- (b) an offer, in accordance with its **Transmission Licence**, by **The Company** to enter into a **CUSC Contract**. A **Bilateral Agreement** is to be entered into for every **Connection Site** (and for certain **Embedded Power Stations** and **Embedded DC Converter Stations** and **Embedded HVDC Systems**) within the first two of the following categories and the existing **Bilateral Agreement** may be required to be varied in the case of the third category:
  - (i) existing **Connection Sites** (and for certain **Embedded Power Stations**) as at the **Transfer Date**;
  - (ii) new **Connection Sites** (and for certain **Embedded Power Stations**, **Embedded DC Converter Stations** and **Embedded HVDC Systems**) with effect from the **Transfer Date**;
  - (iii) a **Modification** at a **Connection Site** (or in relation to the connection of certain **Embedded Power Stations**, **Embedded DC Converter Stations** and **Embedded HVDC Systems** whether or not the subject of a **Bilateral Agreement**) (whether such **Connection Site** or connection exists on the **Transfer Date** or is new thereafter) with effect from the **Transfer Date**.

In this **PC**, unless the context otherwise requires, "connection" means any of these 3 categories.

PC.4.2 **Introduction to Data**

**User Data**

PC.4.2.1 Under the **PC**, two types of data to be supplied by **Users** are called for:

- (a) **Standard Planning Data**; and
- (b) **Detailed Planning Data**,

as more particularly provided in PC.A.1.4.

PC.4.2.2 The **PC** recognises that these two types of data, namely **Standard Planning Data** and **Detailed Planning Data**, are considered at three different levels:

- (a) **Preliminary Project Planning Data**;
- (b) **Committed Project Planning Data**; and
- (c) **Connected Planning Data**,

as more particularly provided in PC.5

PC.4.2.3 **Connected Planning Data** is itself divided into:

- (a) **Forecast Data**;
- (b) **Registered Data**; and
- (c) **Estimated Registered Data**,



as more particularly provided in PC.5.5

PC.4.2.4 Clearly, an existing **User** proposing a new **Connection Site** (or **Embedded Power Station** or **Embedded DC Converter Station** or **Embedded HVDC System**) in the circumstances outlined in PC.4.1) will need to supply data both in an application for a **Bilateral Agreement** and under the **PC** in relation to that proposed new **Connection Site** (or **Embedded Power Station** or **Embedded DC Converter Station** or **Embedded HVDC System** in the circumstances outlined in PC.4.1) and that will be treated as **Preliminary Project Planning Data** or **Committed Project Planning Data** (as the case may be), but the data it supplies under the **PC** relating to its existing **Connection Sites** will be treated as **Connected Planning Data**.

Network Data

PC.4.2.5 In addition, there is **Network Data** supplied by **The Company** in relation to short circuit current contributions ~~and~~ in relation to **OTSUA**.

PC.4.3 Data Provision

PC.4.3.1 Seven Year Statement

To enable the **Seven Year Statement** to be prepared, each **User** is required to submit to **The Company** (subject to the provisions relating to **Embedded Power Stations** and **Embedded DC Converter Stations** and **Embedded HVDC Systems** in PC.3.2) both the **Standard Planning Data** and the **Detailed Planning Data** as listed in parts I and 2 of the Appendix. This data should be submitted in calendar week 24 of each year (although **Network Operators** may delay the submission of data (other than that to be submitted pursuant to PC.3.2(c) and PC.3.2(d)) until calendar week 28) and should cover each of the seven succeeding **Financial Years** (and in certain instances, the current year). Where, from the date of one submission to another, there is no change in the data (or in some of the data) to be submitted, instead of re-submitting the data, a **User** may submit a written statement that there has been no change from the data (or in some of the data) submitted the previous time. In addition, **The Company** will also use the **Transmission Entry Capacity** and **Connection Entry Capacity** data from the **CUSC Contract**, and any data submitted by **Network Operators** in relation to an **Embedded Medium Power Station** not subject to a **Bilateral Agreement** or **Embedded DC Converter Station** not subject to a **Bilateral Agreement**, or **Embedded HVDC System** not subject to a **Bilateral Agreement** in the preparation of the **Seven Year Statement** and to that extent the data will not be treated as confidential.

PC.4.3.2 Network Data

To enable **Users** to model the **National Electricity Transmission System** in relation to short circuit current contributions, **The Company** is required to submit to **Users**, the **Network Data** as listed in Part 3 of the Appendix. The data will be submitted in week 42 of each year and will cover that **Financial Year**.

PC.4.3.3 To enable **Users** to model the **National Electricity Transmission System** in relation to **OTSUA**, **The Company** is required to submit to **Users** the **Network Data**, as listed in Part 3 of Appendix A and Appendix F. **The Company** shall provide the **Network Data** with the offer of a **CUSC Contract** in the case of the data in PC F2.1 and otherwise in accordance with the **OTSDUW Development and Data Timetable**.

PC.4.4 Offer of Terms for Connection

PC.4.4.1 CUSC Contract – Data Requirements/Offer Timing

The completed application form for a **CUSC Contract** to be submitted by a **User** when making an application for a **CUSC Contract** will include:

Commented [AC39]: Post CIM this still applies, but I wonder if it should?

- (a) a description of the **Plant** and/or **Apparatus** (excluding **OTSDUW Plant and Apparatus**) to be connected to the **National Electricity Transmission System** or of the **Modification** relating to the **User's Plant** and/or **Apparatus** (and prior to the **OTSUA Transfer Time**, any **OTSUA**) already connected to the **National Electricity Transmission System** or, as the case may be, of the proposed new connection or **Modification** to the connection within the **User System** of the **User**, each of which shall be termed a "**User Development**" in the **PC**;
- (b) the relevant **Standard Planning Data** as listed in Part 1 of ~~the~~ Appendix **A** (except in respect of any **OTSUA**); and
- (c) the desired **Completion Date** of the proposed **User Development**.
- (d) the desired **Connection Entry Capacity** and **Transmission Entry Capacity**.

The completed application form for a **CUSC Contract** will be sent to **The Company** as more particularly provided in the application form.

PC.4.4.2

Any offer of a **CUSC Contract** will provide that it must be accepted by the applicant **User** within the period stated in the offer, after which the offer automatically lapses. Except as provided in the **CUSC Contract**, acceptance of the offer renders the **National Electricity Transmission System** works relating to that **User Development**, reflected in the offer, committed and binds both parties to the terms of the offer. ~~The User, other than a Network Operator after the PSM Implementation Date.~~ The **User** shall then provide the **Detailed Planning Data** as listed in Part 2 of ~~the~~ Appendix **A** (and in the case of **OTSUA** the **Standard Planning Data** as listed in Part 1 of Appendix A within the timeline provided in PC.A.1.4). In respect of **DPD I** this shall generally be provided within 28 days (or such shorter period as **The Company** may determine, or such longer period as **The Company** may agree, in any particular case) of acceptance of the offer and in respect of **DPD II** this shall generally be provided at least two years (or such longer period as **The Company** may determine, or such shorter period as **The Company** may agree, in any particular case or in the case of **OTSUA** such shorter period as **The Company** shall require) prior to the **Completion Date** of the **User Development**.

PC.4.4.3

Embedded Development Agreement - Data Requirements

The **Network Operator** shall submit the following data in relation to an **Embedded Medium Power Station** not subject to, or proposed to be subject to, a **Bilateral Agreement** or **Embedded DC Converter Station** not subject to, or proposed to be subject to, a **Bilateral Agreement** as soon as reasonably practicable after receipt of an application from an **Embedded Person** to connect to its **System**:

- (a) details of the proposed new connection or variation (having a similar effect on the **Network Operator's System** as a **Modification** would have on the **National Electricity Transmission System**) to the connection within the **Network Operator's System**, each of which shall be termed an "**Embedded Development**" in the **PC** (where a **User Development** has an impact on the **Network Operator's System** details shall be supplied in accordance with PC.4.4 and PC.4.5);
- (b) the relevant **Standard Planning Data** as listed in Part 1 of the Appendix;
- (c) the proposed completion date (having a similar meaning in relation to the **Network Operator's System** as **Completion Date** would have in relation to the **National Electricity Transmission System**) of the **Embedded Development**; and
- (d) upon the request of **The Company**, the relevant **Detailed Planning Data** as listed in Part 2 of the Appendix.

PC.4.4.4

The Network Operator shall provide the **Detailed Planning Data** as listed in Part 2 of the Appendix. In respect of **DPD I**, this shall generally be provided within 28 days (or such shorter period as **The Company** may determine, or such longer period as **The Company** may agree, in any particular case) of entry into the **Embedded Development Agreement** and in respect to **DPD II** this shall generally be provided at least two years (or such longer period as **The Company** may determine, or such shorter period as **The Company** may agree, in any particular case) prior to the **Completion Date** of the **Embedded Development**.

**Commented [AC40]:** As proposed post CIM this is an excluded parag. I can see that this would be OK where the CUSC Contract relates to modifying a BCA re the connection of DG (SoW), but if a DNO was requesting a new / modified connection point should this data be excluded? Where there is a DNO driven modification, then the DNO would need to provide a CIM model (SPD only?) associated the say a new / modified connection point

**Commented [AC41]:** Post CIM this still applies, but I wonder f it should?

**Commented [AC42]:** Part 1 of Appendix A or Appendix G as appropriate

**Commented [AC43]:** Part 1 of Appendix A or Appendix G as appropriat

**Commented [AC44]:** Post CIM this still applies, but I wonder f it should?

**Commented [AC45]:** Part 1 of Appendix A or Appendix G as appropriat

PC.4.5 Complex Connections

PC.4.5.1 The magnitude and complexity of any **National Electricity Transmission System** extension or reinforcement will vary according to the nature, location and timing of the proposed **User Development** which is the subject of the application and it may, in the event, be necessary for **The Company** to carry out additional more extensive system studies to evaluate more fully the impact of the proposed **User Development** on the **National Electricity Transmission System**. Where **The Company** judges that such additional more detailed studies are necessary the offer may indicate the areas that require more detailed analysis and before such additional studies are required, the **User** shall indicate whether it wishes **The Company** to undertake the work necessary to proceed to make a revised offer within the 3 month period normally allowed or, where relevant, the timescale consented to by the **Authority**.

PC.4.5.2 To enable **The Company** to carry out any of the above mentioned necessary detailed system studies, the **User** may, at the request of **The Company**, be required to provide some or all of the **Detailed Planning Data** listed in part 2 of ~~the~~ Appendix A in advance of the normal timescale referred in PC.4.4.2 provided that **The Company** can reasonably demonstrate that it is relevant and necessary.

PC.4.5.3 To enable **The Company** to carry out any necessary detailed system studies, the relevant **Network Operator** may, at the request of **The Company**, be required to provide some or all of the **Detailed Planning Data** listed in Part 2 of ~~the~~ Appendix A in advance of the normal timescale referred in PC.4.4.4 provided that **The Company** can reasonably demonstrate that it is relevant and necessary.

PC.5 PLANNING DATA

PC.5.1 As far as the **PC** is concerned, there are three relevant levels of data in relation to **Users**. These levels, which relate to levels of confidentiality, commitment and validation, are described in the following paragraphs.

Preliminary Project Planning Data

PC.5.2 At the time the **User** applies for a **CUSC Contract** but before an offer is made and accepted by the applicant **User**, the data relating to the proposed **User Development** will be considered as **Preliminary Project Planning Data**. Data relating to an **Embedded Development** provided by a **Network Operator** in accordance with PC.4.4.3, and PC.4.4.4 if requested, will be considered as **Preliminary Project Planning Data**. All such data will be treated as confidential within the scope of the provisions relating to confidentiality in the **CUSC**.

PC.5.3 **Preliminary Project Planning Data** will normally only contain the **Standard Planning Data** unless the **Detailed Planning Data** is required in advance of the normal timescale to enable **The Company** to carry out additional detailed system studies as described in PC.4.5.

Commented [AC46]: Post CIM this still applies, but I wonder if it should?

Commented [AC47]: Or appendix G as appropriate

Commented [AC48]: Post CIM this still applies, but I wonder if it should?

Commented [AC49]: Doesn't apply post CIM

Commented [AC50]: I do wonder about the application of PC.5 post CIM. In practice the DNO would provide an updated solved PSM etc where the concept of DPD, SPS, Preliminary Planning data doesn't really apply - or could it?

Commented [AC51]: Delete carriage returns

Commented [PT(52R51)]: Sub-group Accept

Committed Project Planning Data

PC.5.4 Once the offer for a **CUSC Contract** is accepted, the data relating to the **User Development** already submitted as **Preliminary Project Planning Data**, and subsequent data required by **The Company** under this **PC**, will become **Committed Project Planning Data**. Once an **Embedded Person** has entered into an **Embedded Development Agreement**, as notified to **The Company** by the **Network Operator**, the data relating to the **Embedded Development** already submitted as **Preliminary Project Planning Data**, and subsequent data required by **The Company** under the **PC**, will become **Committed Project Planning Data**. Such data, together with **Connection Entry Capacity** and **Transmission Entry Capacity** data from the **CUSC Contract** and other data held by **The Company** relating to the **National Electricity Transmission System** will form the background against which new applications by any **User** will be considered and against which planning of the **National Electricity Transmission System** will be undertaken. Accordingly, **Committed Project Planning Data**, **Connection Entry Capacity** and **Transmission Entry Capacity** data will not be treated as confidential to the extent that **The Company**:

- (a) is obliged to use it in the preparation of the **Seven Year Statement** and in any further information given pursuant to the **Seven Year Statement**;
- (b) is obliged to use it when considering and/or advising on applications (or possible applications) of other **Users** (including making use of it by giving data from it, both orally and in writing, to other **Users** making an application (or considering or discussing a possible application) which is, in **The Company's** view, relevant to that other application or possible application);
- (c) is obliged to use it for operational planning purposes;
- (d) is obliged under the terms of an **Interconnection Agreement** to pass it on as part of system information on the **Total System**;
- (e) is obliged to disclose it under the **STC**;
- (f) is obliged to use and disclose it in the preparation of the **Offshore Development Information Statement**;
- (g) is obliged to use it in order to carry out its **EMR Functions** or is obliged to disclose it under an **EMR Document**.

To reflect different types of data, **Preliminary Project Planning Data** and **Committed Project Planning Data** are themselves divided into:

- (a) those items of **Standard Planning Data** and **Detailed Planning Data** which will always be forecast, known as **Forecast Data**; and
- (b) those items of **Standard Planning Data** and **Detailed Planning Data** which relate to **Plant** and/or **Apparatus** which upon connection will become **Registered Data**, but which prior to connection, for the seven succeeding **Financial Years**, will be an estimate of what is expected, known as **Estimated Registered Data**.

#### Connected Planning Data

PC.5.5 The **PC** requires that, at the time that a **Statement of Readiness** is submitted under the **Bilateral Agreement** and/or **Construction Agreement**, any estimated values assumed for planning purposes are confirmed or, where practical, replaced by validated actual values and by updated estimates for the future and by updated forecasts for forecast data items such as **Demand**. In the case of an **Embedded Development** the relevant **Network Operator** will update any estimated values assumed for planning purposes with validated actual values as soon as reasonably practicable after energisation. This data is then termed **Connected Planning Data**.

To reflect the three types of data referred to above, **Connected Planning Data** is itself divided into:

- (a) those items of **Standard Planning Data** and **Detailed Planning Data** which will always be forecast data, known as **Forecast Data**; and

- (b) those items of **Standard Planning Data** and **Detailed Planning Data** which upon connection become fixed (subject to any subsequent changes), known as **Registered Data**; and
- (c) those items of **Standard Planning Data** and **Detailed Planning Data** which for the purposes of the **Plant** and/or **Apparatus** concerned as at the date of submission are **Registered Data** but which for the seven succeeding **Financial Years** will be an estimate of what is expected, known as **Estimated Registered Data**,

as more particularly provided in the Appendix.

PC.5.6

**Connected Planning Data**, together with **Connection Entry Capacity** and **Transmission Entry Capacity** data from the **CUSC Contract**, and other data held by **The Company** relating to the **National Electricity Transmission System**, will form the background against which new applications by any **User** will be considered and against which planning of the **National Electricity Transmission System** will be undertaken. Accordingly, **Connected Planning Data**, **Connection Entry Capacity** and **Transmission Entry Capacity** data will not be treated as confidential to the extent that **The Company**:

- (a) is obliged to use it in the preparation of the **Seven Year Statement** and in any further information given pursuant to the **Seven Year Statement**;
- (b) is obliged to use it when considering and/or advising on applications (or possible applications) of other **Users** (including making use of it by giving data from it, both orally and in writing, to other **Users** making an application (or considering or discussing a possible application) which is, in **The Company's** view, relevant to that other application or possible application);
- (c) is obliged to use it for operational planning purposes;
- (d) is obliged under the terms of an **Interconnection Agreement** to pass it on as part of system information on the **Total System**.
- (e) is obliged to disclose it under the **STC**;
- (f) is obliged to use it in order to carry out its **EMR Functions** or is obliged to disclose it under an **EMR Document**.

PC.5.7

**Committed Project Planning Data** and **Connected Planning Data** will each contain both **Standard Planning Data** and **Detailed Planning Data**.

PC.6 PLANNING STANDARDS

PC.6.1 **The Company** shall apply the **Licence Standards** relevant to it in the planning and development of the **National Electricity Transmission System**. **The Company** shall procure that each **Relevant Transmission Licensee** shall apply the **Licence Standards** relevant to planning and development, in the planning and development of the **Transmission System** of each **Relevant Transmission Licensee** and that a **User** shall apply the **Licence Standards** relevant to planning and development, in the planning and development of the **OTSUA**.

PC.6.2 In relation to Scotland, Appendix C lists the technical and design criteria applied in the planning and development of each **Relevant Transmission Licensee's Transmission System**. The criteria are subject to review in accordance with each **Relevant Transmission Licensee's Transmission Licence** conditions. Copies of these documents are available from **The Company** on request. **The Company** will charge an amount sufficient to recover its reasonable costs incurred in providing this service.

PC.6.3 In relation to **Offshore**, Appendix E lists the technical and design criteria applied in the planning and development of each **Offshore Transmission System**. The criteria are subject to review in accordance with each **Offshore Transmission Licensee's Transmission Licence** conditions. Copies of these documents are available from **The Company** on request. **The Company** will charge an amount sufficient to recover its reasonable costs incurred in providing this service.

PC.6.4 In planning and developing the **OTSUA**, the **User** shall comply with (and shall ensure that (as at the **OTSUA Transfer Time**) the **OTSUA** comply with):

- (a) the **Licence Standards**; and
- (b) the technical and design criteria in Appendix E.

PC.6.5 In addition the **User** shall, in the planning and development of the **OTSUA**, to the extent it is reasonable and practicable to do so, take into account the reasonable requests of **The Company** (in the context of its obligation to develop an efficient, co-ordinated and economical system) relating to the planning and development of the **National Electricity Transmission System**.

PC.6.6 In planning and developing the **OTSUA** the **User** shall take into account the **Network Data** provided to it by **The Company** under Part 3 of Appendix A and Appendix F, and act on the basis that the **Plant** and **Apparatus** of other **Users** complies with:

- (a) the minimum technical design and operational criteria and performance requirements set out in either CC.6.1, CC.6.2, CC.6.3 and CC.6.4 or ECC.6.1, ECC.6.2, ECC.6.3 and ECC.6.4 ; or
- (b) such other criteria or requirements as **The Company** may from time to time notify the **User** are applicable to specified **Plant** and **Apparatus** pursuant to PC.6.7.

PC.6.7 Where the **OTSUA** are likely to be materially affected by the design or operation of another **User's Plant** and **Apparatus** and **The Company**:

- (a) becomes aware that such other **User** has or is likely to apply for a derogation under the Grid Code;
- (b) is itself applying for a derogation under the Grid Code in relation to the **Connection Site** on which such other **User's Plant** and **Apparatus** is located or to which it otherwise relates; or
- (c) is otherwise notified by such other **User** that specified **Plant** or **Apparatus** is normally capable of operating at levels better than those set out in CC.6.1, CC.6.2, CC.6.3 and CC.6.4 or ECC.6.1, ECC.6.2, ECC.6.3 and ECC.6.4,

**The Company** shall notify the **User**.

PC.7 **PLANNING LIAISON**

PC.7.1 This PC.7 applies to **The Company** and **Users**, which in PC.7 means

- (a) **Network Operators**
- (b) **Non-Embedded Customers**

PC.7.2 As described in PC.2.1 (b) an objective of the **PC** is to provide for the supply of information to **The Company** by **Users** in order that planning and development of the **National Electricity Transmission System** can be undertaken in accordance with the relevant **Licence Standards**.

PC.7.3 **Grid Code** amendment B/07 ("Amendment B/07") implemented changes to the **Grid Code** which included amendments to the datasets provided by both **The Company** and **Users** to inform the planning and development of the **National Electricity Transmission System**. **The Authority** has determined that these changes are to have a phased implementation. Consequently the provisions of Appendix A to the **PC** include specific years (ranging from 2009 to 2011) with effect from which certain of the specific additional obligations brought about by Amendment B/07 on **The Company** and **Users** are to take effect. Where specific provisions of paragraphs PC.A.4.1.4, PC.A.4.2.2 and PC.A.4.3.1 make reference to a year, then the obligation on **The Company** and the **Users** shall be required to be met by the relevant calendar week (as specified within such provision) in such year.

In addition to the phased implementation of aspects of Amendment B/07, **Users** must discuss and agree with **The Company** by no later than 31 March 2009 a more detailed implementation programme to facilitate the implementation of **Grid Code** amendment B/07.

It shall also be noted by **The Company** and **Users** that the dates set out in PC.A.4 are intended to be minimum requirements and are not intended to restrict a **User** and **The Company** from the earlier fulfilment of the new requirements prior to the specified years. Where **The Company** and a **User** wish to follow the new requirements from earlier dates than those specified, this will be set out in the more detailed implementation programme agreed between **The Company** and the **User**.

The following provisions of PC.7 shall only apply with effect from 1 January 2011.

PC.7.4 Following the submission of data by a **User** in or after week 24 of each year **The Company** will provide information to **Users** by calendar week 6 of the following year regarding the results of any relevant assessment that has been made by **The Company** based upon such data submissions to verify whether **Connection Points** are compliant with the relevant **Licence Standards**.

PC.7.5 Where the result of any assessment identifies possible future non-compliance with the relevant **Licence Standards**, **The Company** shall notify the relevant **User(s)** of this fact as soon as reasonably practicable and shall agree with **Users** any opportunity to resubmit data to allow for a reassessment in accordance with PC.7.6.

PC.7.6 Following any notification by **The Company** to a **User** pursuant to PC.7.5 and following any further discussions held between the **User** and **The Company**:

- (i) **The Company** and the **User** may agree revisions to the **Access Periods** for relevant **Transmission Interface Circuits**, such revisions shall not however permit an **Access Period** to be less than 4 continuous weeks in duration or to occur other than between calendar weeks 10 and 43 (inclusive); and/or,
- (ii) The **User** shall as soon as reasonably practicable
  - (a) submit further relevant data to **The Company** that is to **The Company's** reasonable satisfaction; and/or,
  - (b) modify data previously submitted pursuant to this **PC**, such modified data to be to **The Company's** reasonable satisfaction; and/or
  - (c) notify **The Company** that it is the intention of the **User** to leave the data as originally submitted to **The Company** to stand as its submission.

Commented [AC53]: This PC7 still applies post CIM, yet there is overlap with PC.G.7.1

Commented [AC54]: I think these parags can be deleted

Commented [AC55]: ditto

Commented [AC56]: Would be worth checking the timeline to see if these weeks are OK both pre and post CIM. If not we may need a post-CIM parag.

Commented [AC57]: Ditto re whether these weeks work pre or post CIM.

PC.7.7 Where an **Access Period** is amended pursuant to PC.7.6 (i) **The Company** shall notify **The Authority** that it has been necessary to do so.

PC.7.8 When it is agreed that any resubmission of data is unlikely to confirm future compliance with the relevant **Licence Standards** the **Modification** process in the **CUSC** may apply.

PC.7.9 A **User** may at any time, in writing, request further specified **National Electricity Transmission System** network data in order to provide **The Company** with viable **User** network data (as required under this **PC**). Upon receipt of such request, **The Company** shall consider, and where appropriate provide such **National Electricity Transmission System** network data to the **User** as soon as reasonably practicable following the request.

PC.8 OTSDUW PLANNING LIAISON

PC.8.1 This PC.8 applies to **The Company** and **Users**, which in PC.8 means **Users** undertaking **OTSDUW**

PC.8.2 As described in PC.2.1 (e) an objective of the **PC** is to provide for the supply of information between **The Company** and a **User** undertaking **OTSDUW** in order that planning and development of the **National Electricity Transmission System** can be co-ordinated.

PC.8.3 Where the **OTSUA** also require works to be undertaken by any **Relevant Transmission Licensee** on its **Transmission System** **The Company** and the **User** shall throughout the construction and commissioning of such works:

- (a) co-operate and assist each other in the development of co-ordinated construction programmes or any other planning or, in the case of **The Company**, analysis it undertakes in respect of the works; and
- (b) provide to each other all information relating to, in the case of the **User** its own works and, in the case of **The Company**, the works on the **Transmission Systems** reasonably necessary to assist each other in the performance of that other's part of the works, and shall use all reasonable endeavours to co-ordinate and integrate their respective part of the works; and

the **User** shall plan and develop the **OTSUA**, taking into account to the extent that it is reasonable and practicable to do so the reasonable requests of **The Company** relating to the planning and development of the **National Electricity Transmission System**.

PC.8.4 Where **The Company** becomes aware that changes made to the investment plans of any **Relevant Transmission Licensee** may have a material effect on the **OTSUA**, **The Company** shall notify the **User** and provide the **User** with the necessary information about the relevant **Transmission Systems** sufficient for the **User** to assess the impact on the **OTSUA**.

Commented [AC58]: Missing full stop

Commented [PT(59R58)]: Sub-group Accept



**PC.9 SUBMISSION OF SYSTEM MODELS AND INFORMATION BY NETWORK OPERATOR TO THE COMPANY**

**PC.9.1 General**

**PC.9.1.1** PC.9 details the **minimum** planning data to be submitted by **Network Operators to The Company**.

**Commented [AC60]:** Delete - it specifies all the planning data if only because there are provisions providing more data where reasonably required etc.

**PC.9.1.2** Compliance with the data submission requirements within PC.9 shall only apply after the **PSM Implementation Date**.

**PC.9.1.3** The **Network Operator** shall use reasonable endeavours to obtain all applicable information required by PC.9 from any user connected to the **Network Operator's System**, such that the information provided is the best information available at the time of submission.

**Commented [VG61]:** Is this just portmanteau because Network Operator's and System are separately defined terms?

**PC.9.2 Purpose**

**PC.9.2.1** The purpose of the data submission set out in PC.9 is to ensure that the **Network Operators** provide sufficient information to **The Company** so that it:

- a) Can provide information to the **Relevant Transmission Licensee** so that they can establish the previous year, current year and future years compliance of the **NETS** with the **NETS SQSS**;
- b) Can provide information to the **Relevant Transmission Licensee** so that they can establish that the **NETS** complies with relevant technical standards;
- c) Can provide information to the **Relevant Transmission Licensee** so that they can establish that the **NETS** has sufficient capability to accommodate the connection of, and export from, the embedded generation as considered in the **CUSC Evaluation of Transmission Impact** process; and
- d) Can support the creation of operational models for use in operational timescales.

**Commented [AC62]:** Reading this list it implies that the ESO has no obligations itself to comply with SQSS. Is SQSS Compliance not in the ESOs licence?  
Wondering if there is an extra bullet required.

**Commented [VG63]:** Bold - both NETS and SQSS are defined terms

**PC.9.2.2** The **Data Freeze Date** for the submission in calendar week 2 shall be 31 October of the previous year. The **Data Freeze Date** for the submission in calendar week 28 shall be 31 March of that year.

**Commented [VG64]:** Is 'the' needed?

**Commented [VG65]:** Bold - it is proposed to create this as a defined term.

**Commented [AC66]:** Can create operational models....  
The subject in the sentence is The Company who does the creation of the models.

**PC.9.2.3** PC.9 uses definitions of **Group Demand, Latent Demand, Measured Demand, Embedded Generation Export, Embedded Generation Import** and **Gross Demand**. The interpretation of these definitions is illustrated below:

**Commented [RS67]:** Suggest reframe as Minimum Data Freeze Date (see track changes in glossary) to make less onerous for model maintenance and update

**Formatted: Highlight**

**Formatted: Highlight**

**Commented [VG68]:** This isn't illustrated below - Measured Import is but not Measured Demand.

**Commented [AC69]:** Unbold all the commas

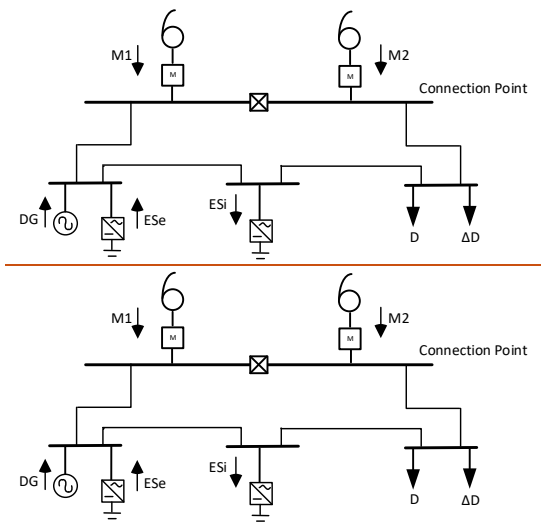

M1, M2 Measurement at the **Connection Point**  
DG export from embedded generation other than from **Electricity Storage**  
ESi import to **Electricity Storage**  
ESe export from **Electricity Storage**  
D aggregate network / customer demand  
ΔD **Latent Demand**

Where:

**Group Demand** =  $D + \Delta D$  [underlying customer demand]  
**Group Demand** =  $(M1 + M2) + (DG + ESe) - ESi + \Delta D = (D + \Delta D)$   
**Latent Demand** =  $\Delta D$  [factors that modify the underlying customer demand]  
**Embedded Generation Export** =  $DG + ESe$   
**Embedded Generation Import** =  $ESi$   
**Measured Import** =  $M1 + M2$   
**Gross Demand** =  $(D + \Delta D) + ESi$   
**Net Demand** =  $M1 + M2$

PC.9.3 Submissions

PC.9.3.1 Submissions by the **Network Operator** to **The Company** include:

- Routine submissions each year in calendar week 2 and calendar week 28. These are described in PC.9.3.2 and PC.9.3.3 respectively. A diagram illustrating the coordination of submissions between the **Network Operators** and **The Company** is provided in PC.G.9; and
- Information provided as part of a **CUSC Evaluation of Transmission Impact** assessment application. This information is described in PC.9.3.4.

Nothing shall prevent the submission of data detailed in PC.9 at additional points during the year where agreed between **The Company** and the **Network Operator**.

At **The Company's** reasonable request and where agreed by the **Network Operator**, additional data on the **Network Operator's System** beyond that described in PC.9 shall be provided.

PC.9.3.2 The data submitted in calendar week 2 shall comprise:

PC.9.3.2.1 A **Solved PSM** of the **Network Operator's System**, which conforms to the **Subtransmission PSM** requirements as described in PC.9.4.2 and which includes:

- Structural Data** as of the **time of the Data Freeze Date** for the submission in calendar week 2;
- Situation Data** corresponding to the date and time of **NETS minimum** as specified by **The Company** annually in calendar week 43 of the previous year;
- Solution Data** resulting from a power flow calculation executed on the **Structural** and **Situation Data**;
- Solution Data** which includes results from a minimum fault level study executed on the **Structural** and **Situation Data**; and
- Diagram Layout Data** describing diagrams of **Structural** and a subset of **Situational Data**.

**Commented [VG70]:** So doesn't include import from Embedded Storage.

**Commented [SA71]:** At some instances the measured demand would include Electricity Storage Import. From this equation, it means that the Group demand should exclude any Electricity Storage Import. Is that the case?

**Commented [VG72]:** Assuming that import from DG other than Storage is negligible.

**Commented [AC73]:** Is it worth mulling over whether we should consider the import to non-ES generation?

**Commented [AC74R73]:** Agreed not to at the moment

**Commented [AC75]:** Should this be DG as well as ESi - prob yes

**Commented [AC76R75]:** Not at the moment

**Commented [VG77]:** Unbold - this is not a defined term or should it read Measured Demand

**Commented [VG78]:** Or Gross Demand = Group Demand + Embedded Storage Import but the addition of ESi simply negates the subtraction done at the Group Demand calculation stage. Is this correct?

$D = (M1 + M2) + (DG + ESe) - ESi$  so Gross D =  $(M1 + M2) + (DG + ESe)$   
 Ignoring the delta D bit

**Commented [AC79]:** Close up space

**Commented [VG80]:** = Measured Import but noting that Measured Demand is proposed to be defined not Measured Import.

**Commented [AC81]:** Looks good - need to review

**Commented [AC82]:** AMC to check what's in here.

**Commented [AC83]:** ...time on the ....

**Commented [AC84R83]:** As at the data freeze...

**Commented [AC85]:** Check if this should be NETS minimum demand

**Commented [VG86]:** Structural Data

**Commented [VG87]:** Structural Data

**Commented [VG88]:** This is not defined in the proposed G&D

**Commented [AC89]:** Not a defined term. Not too sure what it should be.

**Commented [AC90R89]:** Diagram data

**Commented [VG91]:** Structural Data

PC.9.3.2.2 A **PSM Scenario Document** and a **PSM Change Document**, conformant to the requirements described in PC.G.5 and PC.G.6, respectively.

PC.9.3.2.3 A collection of individual **PSDMs** describing new or modified connections or proposed alterations to the **Network Operator's System** that the **Network Operator** is aware of at the **Data Freeze Date**. Individual **PSDMs** shall be supplied for all of the following not represented in the **Structural Data of the Solved PSM**:

- a) each new or modified generation and/or load connection where the relevant customer has accepted a connection offer from **Network Operator**; and
- b) each authorised reinforcement, asset replacement scheme or similar related to the **Network Operators' System**

PC.9.3.2.4 **Schedule 21C**, populated with demand and generation data corresponding to the date and time of **NETS minimum** as specified by **The Company** annually in calendar week 43 of the previous year. **Schedule 21C** provides information including:

- a) **Group Demand** and the output from **Embedded Generation** for each **Connection Point** at:
  - i. the time of **NETS minimum** specified by **The Company**; and
  - ii. forecasts for future times of **NETS minimum** specified by **The Company**.

PC.9.3.2.5 **Schedule 21D**, populated with demand and generation data relating to a date and time established by the **Network Operator** as being the time and date of the **Connection Point** summer minimum **Gross Demand**. This summer minimum relates to a time between between between the hours 04:00 and 06:00 (BST) between April to October inclusive. **Schedule 21D** provides information including:

- a) **Gross Demand** and the output from embedded generation for each **Connection Point** at:
  - i. the time of peak **Connection Point** summer minimum **Gross Demand**.

PC.9.3.2.6 **Schedule 21E**, populated with demand and generation data relating to a date and time established by the **Network Operator** as being the time and date of the **Connection Point** summer daylight minimum **Gross Demand**. Summer daylight relates to a time between the hours 10:00 and 16:00 (BST) between April to October inclusive. **Schedule 21E** provides information including:

- a) **Gross Demand** and the output from embedded generation for each **Connection Point** at:
  - i. the time of peak **Connection Point** summer daylight minimum **Gross Demand**.

PC.9.3.2.7 **Schedule 21G**, populated with information about **Embedded Power Stations with Registered Capacities** greater than or equal to 1MW, that provides additional detail related to the generation modelling which is part of the **Structural Data of the Solved PSM** as described in PC.9.4.2.2.3.

PC.9.3.2.8 **Schedule 21H**, populated with information for each **Connection Point** about **Embedded Power Stations with Registered Capacities** less than 1MW, that provides additional detail related to the generation modelling which is part of the **Structural Data of the Solved PSM** as described in PC.9.4.2.2.3.

PC.9.3.2.9 **Schedule 21I**, populated with information for each **Connection Point** detailing:

- **Network Operator System** constraints on **Embedded Generation Capacity** (MW), specifying the outturn and forecast constrained capacity (MW) of any **Generating Unit** at an **Embedded Large Power Station** where the **Network Operator's System** constrains the generation capacity.

For the avoidance of doubt,

- A **Generating Unit** as referred to above includes:

**Commented [VG92]:** What is a PSDM?

**Commented [VG93]:** Is it load or demand or does it really matter?

**Commented [AC94]:** Add full stop

**Commented [AC95]:** A copy of Data Registration Code Schedule 21C

**Commented [VG96]:** This is a defined term in the GCode - should it be bold here or it in being used in a different context?

**Commented [VG97]:** NETS minimum what? Demand?

**Commented [AC98]:** ...NETS minimum demand....

**Commented [AC99]:** ...the data and time of....

**Commented [AC100]:** As a general point should we refer to NETS minimum demand - to avoid any confusion with say the NETS minimum fault level? This would align with the proforma schedules and other cardinal points where we refer to 'demand'

I'll not comment on this again.

**Commented [AC101]:** ..dates and times....

**Commented [AC102]:** Data Registration Data Code Schedule 21D...

**Commented [VG103]:** This is a defined term in the GCode - should it be bold here or it in being used in a different context?

**Commented [AC104]:** ...the data and time....

Consistency with elsewhere

**Commented [AC105]:** This summer minimum relates to a time between the hours 04:00 and 06:00 (BST) and a date between 1 April and 31 October inclusive

**Commented [AC106]:** ...the data and time ....

**Commented [AC107]:** Data Registration Data Code Schedule 21E....

**Commented [VG108]:** This is a defined term in the GCode - should it be bold here or it in being used in a different context?

**Commented [AC109]:** And a date between 1 April and 31 October inclusive.

**Commented [AC110]:** Data Registration Data Code Schedule....

**Commented [AC111]:** ...with a **Registered Capacity** greater than or....

**Commented [AC112]:** Data Registration Data Code Schedule....

**Commented [AC113]:** ...with a **Registered Capacity** less ....

**Commented [AC114]:** I wonder if it would be appropriate to provide the access period data in week 2 as generally the access periods relate to the 'summer' rather than the 'winter' period. Accept that this would require some further thoughts.

How does this relate to a Large BESS? Is the BSC definition of Generation Capacity correct and appropriate?

**Commented [AC115]:** I think we should review the requirement to include the far more likely scenario relation to OTS / ANM associated with delegated technical limits.

**Formatted:** Font color: Auto

- A CCGT Unit or Synchronous Generating Unit within a Synchronous Power Generating Module;
  - A Power Park Module (including DC Connected Power Park Modules);
  - An Offshore Transmission System at an Interface Point; or
  - An Embedded HVDC System or DC Converter at an Embedded DC Converter Station.
- Constrained capacity is a limitation of generation capacity due to the Network Operator's System in which it is Embedded.
- Where Generating Units are connected to a Network Operator's User System via a busbar arrangement which is or is expected to be operated in separate sections, details of busbar running arrangements and connected circuits at the substation to which the Embedded Generating Unit is connected, sufficient for The Company to determine where the MW generated by each Generating Unit would appear onto the National Electricity Transmission System;
- any Reactive Dispatch Network Restrictions (in MVA);
  - Network Operator System constraints on Offshore Transmission Systems, specifying outturn and forecast maximum import and export capacities (MW) for each Offshore Transmission System at an Interface Point where the Network Operator's System places a constraint on the capacity of the Offshore Transmission System.

Commented [AC116]: Defined term

Commented [SA117]: Does this refer to the curtailed capacity? is the requirement to identify the curtailed capacity and forecasted curtailed capacity? Further clarity on the requirement is needed.

Commented [AC118]: I think this is a defined term

Commented [AC119]: ...in which the Large Power Station is Embedded.

Commented [VG120]: Active Power?

Commented [VG121]: bold

Commented [AC122]: Bold

AMC suggested alternative text 11 Oct 2024

PC.9.3.2.9 A copy of Data Registration Code Schedule 211, populated with information for each Connection Point detailing:

- a) Where a Network Operator's System imposes constraints on the import to or export from a Generating Unit at a Embedded Large Power Station, the following data:
1. outturn and forecast constrained capacity (MW)
  2. any Reactive Dispatch Network Restriction (MVA)

For the avoidance of doubt, a Generating Unit as referred to above includes:

1. A CCGT Unit or Synchronous Generating Unit within a Synchronous Power Generating Module;
2. A Power Park Module (including DC Connected Power Park Modules);
3. An Offshore Transmission System at an Interface Point; or
4. An Embedded HVDC System or DC Converter at an Embedded DC Converter Station.

Constrained capacity is a limitation of the import to or export from a Generating Unit at an Embedded Large Power Station, due to the Network Operator's System in which the Large Power Station is Embedded, arising from an intrinsic limitations of the Network Operator's System or an automated or manual control system designed to limit power flows in the Network Operator's System in certain scenarios.

Where Generating Units are connected to a Network Operator's User System via a busbar arrangement which is or is expected to be operated in separate sections, details of busbar running arrangements and connected circuits at the substation to which the Embedded Generating Unit is connected, sufficient for The Company to determine where the MW generated by each Generating Unit would appear onto the National Electricity Transmission System, shall be provided.

Formatted: Not Highlight

Commented [P123]: Do we want to preface all the other schedule descriptions with this wording, too?

Commented [AC124R123]: I think so.

Commented [SM125R123]: resolved

Formatted: Font color: Auto, Not Highlight

Formatted: Font color: Auto, Not Highlight

Formatted: Indent: Left: 0 cm, Hanging: 2.5 cm

Formatted: Not Highlight

Commented [P126]: Either remove the 'an' or the 's' on the end of limitations.

Commented [AC127R126]: Agreed.....arising from intrinsic limitations.....

Commented [SM128R126]: resolved

Formatted: Font color: Auto, Not Highlight

Formatted: Not Highlight

Formatted: Not Highlight

Formatted: Not Highlight

Commented [P129]: The previous 2 paragraph are 'whole' sentences which explain a concept. They are not really part of a list. It would probably be better if this were a whole sentence, too.

Commented [AC130R129]: Apologies, Pat, I'm not sure I follow the point.

Commented [SM131R129]: Resolved

Formatted: Font: Not Bold, Not Highlight

Formatted: Not Highlight

Formatted: Not Highlight

b) Where a **Network Operator System** imposes constraints on the operation of a **Offshore Transmission System** at an **Interface Point** the following data:

1.      outturn and forecast maximum import capacity (MW); and  
         —outturn and forecast maximum export capacity (MW)
2.

PC.9.3.2.10 Schedule 21J, populated with the **Network Operator's** forecast of **Registered Capacity from Power Stations** and **Customer Generating Plant**, aggregated by **Aggregated Energy Source per Connection Point**.

PC.9.3.3 The data submitted in calendar week 28 shall comprise:

PC.9.3.3.1 A **Solved PSM** of the **Network Operator's System**, which conforms to the **Subtransmission PSM** requirements as described in PC.9.4.2 and which includes:

- a) **Structural Data** as of the time of the **Data Freeze Date** for the submission in calendar week 28;
- b) **Situation Data** corresponding to the date and time of **NETS peak** as specified by **The Company** annually in calendar week 17;
- c) **Solution Data** resulting from a power flow calculation executed on the **Structural** and **Situation Data**;
- d) **Solution Data** which includes results from a maximum fault level study executed on the **Structural** and **Situation Data**; and
- e) **Diagram Layout Data** describing diagrams of **Structural** and a subset of **Situational Data**.

PC.9.3.3.2 A **PSM Scenario Document** and a **PSM Change Document**, conformant to the requirements described in PC.G.5 and PC.G.6, respectively.

PC.9.3.3.3 A collection of individual **PSDMs** describing new or modified connections or proposed alterations to the **Network Operator's System** that the **Network Operator** is aware of at the **Data Freeze Date**. Individual **PSDMs** shall be supplied for all of the following not represented in the **Structural Data** of the **Solved PSM**:

- a) each new or modified generation and/or load connection where the relevant customer has accepted a connection offer from **Network Operator**; and
- b) each authorised reinforcement, asset replacement scheme or similar related to the **Network Operator's System**

PC.9.3.3.4 Schedule 21A populated with demand and generation data corresponding to the date and time of **NETS peak** as specified by **The Company** annually in calendar week 17. Schedule 21A provides information including:

- a) **Group Demand** and the output from **Embedded Generation** for each **Connection Point** at:
  - i. the time of **NETS peak** specified by **The Company**; and
  - ii. forecasts for future times of **NETS peak** specified by **The Company**.

PC.9.3.3.5 Schedule 21B, populated with demand and generation data relating to a date and time established by the **Network Operator** as being the time and date of the peak **Connection Point peak Group Demand**. Schedule 21B provides information including:

- a) **Group Demand**, the output from **Embedded Generation** for each **Connection Point** at:
  - i. the time of peak **Connection Point Group Demand**; and

**Formatted:** Outline numbered + Level: 2 + Numbering Style: 1, 2, 3, ... + Start at: 1 + Alignment: Left + Aligned at: 4.44 cm + Tab after: 5.08 cm + Indent at: 5.08 cm

**Formatted:** Outline numbered + Level: 2 + Numbering Style: 1, 2, 3, ... + Start at: 1 + Alignment: Left + Aligned at: 4.44 cm + Tab after: 5.08 cm + Indent at: 5.08 cm

**Formatted:** Outline numbered + Level: 2 + Numbering Style: 1, 2, 3, ... + Start at: 1 + Alignment: Left + Aligned at: 4.44 cm + Tab after: 5.08 cm + Indent at: 5.08 cm

**Commented [AC132]:** Change to: Data Registration Code Schedule 21J, populated with the **Network Operator's** forecast of **Power Station Registered Capacity** aggregated by **Aggregated Energy Source**, per **Connection Point**.

**Commented [PT(133R132)]:** SuB Group Accepts

**Commented [RS134]:** Is this now all Registered Capacity (including at LV) or just 1-99MW as previously in Week 28?

**Commented [AC135]:** Is this different than Power Station?

**Commented [PT(136R135)]:** Sub Group - Customer Generating Plant is a subset of Generating Plant as defined in Glossary, so should be removed. AC to review Electric Act to confirm if term can be removed. For consistency term to be removed?

**Commented [AC137]:** Delete space

**Commented [BS138]:** The requirement not specify which ...

**Commented [AC139]:** ...time on the ...

**Commented [PT(140R139)]:** Sub-group Accept

**Commented [AC141]:** ..NETS peak demand ....

**Commented [PT(142R141)]:** Sub-group Accept

**Commented [VG143]:** Structural Data

**Commented [VG144]:** Structural Data

**Commented [AC145]:** See comment above - not a define ...

**Commented [AC146]:** See comment above - not a define ...

**Commented [PT(147R146)]:** Sub-group action - term to b ...

**Commented [VG148]:** Structural Data

**Commented [VG149]:** Situation

**Commented [AC150]:** Full stop

**Commented [PT(151R150)]:** Sub-group Accept

**Commented [AC152]:** Data Registration Code Schedule.....

**Commented [PT(153R152)]:** Sub-group Accept

**Commented [VG154]:** Bold?

**Commented [AC155]:** ...NETS peak demand....

**Commented [PT(156R155)]:** Sub-group Accept

**Commented [AC157]:** ..NETS peak demand....

**Commented [PT(158R157)]:** Sub-group Accept

**Commented [AC159]:** ..NETS peak demand....

**Commented [AC160]:** Data Registration Code Schedule.....

**Commented [PT(161R160)]:** Sub-group Accept

**Commented [VG162]:** Bold?

**Commented [PT(163)]:** Sub-group Delete (,) and replace ...

**Commented [AC164]:** ...the time and date of the peak.....

**Commented [PT(165R164)]:** Sub-group Accept

**Commented [AC166]:** ...Connection Point peak Group ...

**Commented [PT(167R166)]:** Sub-group Accept

- ii. forecasts of the peak **Connection Point Group Demand**.
- b) Associated **Connection Point** data at the time of peak **Connection Point Group Demand**. Where an associated **Connection Point** is normally operated in parallel with the **Connection Point**, consideration shall be given to presenting data for the associated **Connection Point** and the **Connection Point** as if it was a single **Connection Point**.
- c) A reference to the post fault actions, associated network reconfigurations and demand transfers which shall be described in more detail in the **PSM Scenario Document**.

PC.9.3.3.6 **Schedule 21F**, populated with demand and generation data relating to a date and time established by the **Network Operator** as being the time and date of the **Connection Point peak Group Demand** during the **Access Period**. **Schedule 21F** provides information including:

- a) **Group Demand** and the output from **Embedded Generation** for each **Connection Point** at:
  - i. the time of the **peak Connection Point Group Demand** during the **Access Period**; and
  - ii. forecasts of the **Connection Point Group Demand** during the **Access Period**.

b) Associated **Connection Point** data at the time of peak **Connection Point Group Demand** during during during during the **Access Period**. Where an associated **Connection Point** is normally operated in parallel with the **Connection Point**, consideration shall be given to presenting data for the associated **Connection Point** and the **Connection Point** as if it was a single **Connection Point**.

c) A reference to the post fault actions, associated network reconfigurations and demand transfers which shall be described in more detail in the **PSM Scenario Document**.

PC.9.3.3.7 **Schedule 17**, populated with **Access Group(s)** and **Access Periods** data demonstrating the maintainability of the **Transmission Interface Circuits**.

PC.9.3.3.8 **Schedule 21G**, as described in PC.9.3.2.7, **Schedule 21H** as described in PC.9.3.2.8, and **Schedule 21I**, as described in PC.9.3.2.9.

PC.9.3.3.9 **Schedules 12a, 12b and 12c**, populated in relation to **Demand Control** as described in OC.6.6.2, OC.6.5.3 and OC.6.7.2.

PC.9.3.3.10 **Schedule 10a**, populated with:

- a) The forecast **Demand (Active Power)** profile for the **Network Operator's System** (summed over all **Grid Supply Points**) for the days of the forecast yearly peak **Demand** on the **Network Operator's System** (as determined by the **Network Operator**) giving the numerical value of the maximum half-hourly average **Demand** that, in the **Network Operator's** opinion, could reasonably be imposed on on on on the **National Electricity Transmission System**; and
- b) The forecast half-hourly average **Demand** with generation netted out on the **Network Operator's System** for the forecast peak half-hours of the **Network Operator's System Demand**.

PC.9.3.3.11 **Schedule 10b**, populated with:

- a) The forecast **Demand (Active Power)** profile for the **Network Operator's System** (summed over all **Grid Supply Points**) for the days of the forecast **NETS** peak demand specified by **The Company**, giving the numerical value of the maximum half-hourly average **Demand** that, in the **Network Operator's** opinion, could reasonably be imposed on the **NETS**;

- Commented [AC168]: forecasts for future times of ....
- Commented [PT(169R168)]: Sub-group Accept change to (forecasts of the **Connection Point Peak Group Demand** times and dates)
- Commented [AC170]: ...**Connection Point peak Group Demand**....
- Commented [AC171]: ....the date and time of the **Connection Point peak Group Demand**....
- Commented [PT(172R171)]: Sub-group Accept
- Commented [AC173]: Missing full stop
- Commented [PT(174R173)]: Sub-group Accept
- Commented [AC175]: ...any post fault actions.....
- Commented [PT(176R175)]: Sub-group Accept
- Commented [AC177]: Data Registration Code Schedule.....
- Commented [PT(178R177)]: Sub-group Accept
- Commented [AC179]: As mentioned earlier, I wonder if this should be provided in week 2 rather than 28.
- Commented [PT(180R179)]: Work Group Consultation to decide
- Commented [PT(181)]: Sub-group - move to **Connection Point Peak Group Demand**
- Commented [PT(182)]: Sub-group - move to **Connection Point Peak Group Demand**
- Commented [AC183]: ....the date and time of the **Connection Point peak Group Demand**....
- Commented [PT(184R183)]: Sub-group Accept
- Commented [AC185]: ...any post fault actions.....
- Commented [PT(186R185)]: Sub-group Accept
- Commented [AC187]: Data Registration Code Schedule.....
- Commented [PT(188R187)]: Sub-group Accept
- Commented [AC189]: We are proposing a post CIM schedule which is different to the existing **Schedule 17** (which may have been superseded by the ESO guidance document 17). The new **Schedule** needs to have a different number. (...)
- Commented [PT(190R189)]: Sub-group Accept - New (...)
- Commented [AC191]: ..**Access Period**... singular
- Commented [PT(192R191)]: Sub-group - with the (...)
- Commented [AC193]: Data Registration Code Schedule.....
- Commented [PT(194R193)]: Sub-group Accept
- Commented [AC195]: There are existing schedules 12 ar (...)
- Commented [PT(196R195)]: Sub-group - propose new (...)
- Commented [AC197]: Assuming these references are (...)
- Commented [PT(198R197)]: Sub-group Accept
- Commented [AC199]: Data Registration Code Schedule .....
- Commented [PT(200R199)]: Sub-group Accept
- Commented [AC201]: Looking at **Schedule 10** I think we (...)
- Commented [PT(202R201)]: Sub-group Accept
- Commented [AC203]: ..average **Active Power Demand** (...)
- Commented [AC204]: Is this what the ESO wants? Net / (...)
- Commented [AC205]: Replace with (...)
- Commented [AC206]: Data Registration Code Schedule.....
- Commented [AC207]: This proposed **10A** needs a new p (...)
- Commented [AC208]: ...forecast **Active Power Demand** (...)
- Commented [PT(209R208)]: Sub-group - except refer to (...)

- b) The actual and weather corrected outturn half-hourly average Demand (Active Power) on the Network Operator's System for the theeethe half-hour of the NETS peak specified by The Company;
- c) The actual outturn Demand with generation netted out on the Network Operator's System for the half-hour of the NETS peak demand specified by The Company; and
- d) The forecast half-hourly average Demand with generation netted out on the Network Operator's System for the forecast peak half-hours of the NETS demand specified by The Company;

PC.9.3.3.12 Schedule 10d, populated with:

- a) The forecast Demand (Active Power) profile for the Network Operator's System (summatmed over all Grid Supply Points) for the days of the forecast NETS minimum demand specified by The Company, giving the numerical value of the maximum half-hourly average Demand that, in the Network Operator's opinion, could reasonably be imposed on the NETS; and
- b) The forecast half-hourly average with generation netted out Demand on the Network Operator's System for the forecast minimum half-hours of the NETS demand specified by The Company;

PC.9.3.3.13 Table 11d, populated with the total Active Energy used on the Network Operator's System (summatmed over all Grid Supply Points) in the preceding Financial Year, both outturn and weather corrected, together with a prediction for the current financial year. Each Active Energy submission shall be subdivided into the following categories of Customer tariff:

- LV1
- LV2
- LV3
- HV
- EHV
- Traction
- Lighting

In addition, the total Network Operator System losses and the Active Energy provided by Embedded Small Power Stations and Embedded Medium Power Stations shall be supplied.

PC.9.3.4 The information in support of a request to The Company by a Network Operator for an Evaluation of Transmission Impact assessment shall comprise:

- a) Technical information in compliance with PC.9.4.2.2.3, as appropriate, and the proposed connection date in respect of the Power Stations associated with the Evaluation of Transmission Impact assessment and a description of any proposed alteration to the Network Operator System required to accommodate the proposed connection(s); and
- b) A representation of the Network Operator System at the time of the proposed connection(s), either as a PSM or a combination of a PSM and PSDMs, as appropriate.

PC.9.4 Network Operator Subtransmission PSM

PC.9.4.1 Scope

PC.9.4.1.1 The Subtransmission PSM is intended to provide data sufficient for power system studies which support the activities outlined in PC.9.2.1, including:

- a) power flow calculations; and
- b) short circuit calculations in accordance with EREC G74.

**Commented [AC210]:** The is no place in 10B to enter this.

10A refers to ACS not weather corrected - which is correct?

**Commented [PT(211R210)]:** Sub-group Accept - tidy up 10 a, b, c in new schedules  
Review Weather correcting terms to ensure the correct ones are used.

**Commented [AC212]:** ...forecast Active Power Demand for the Network Operator's User System (summatmed over all Connection Points) for the half hour of the date and time of the forecast NETS peak demand specified by .....

**Commented [PT(213R212)]:** Sub-group Accept

**Commented [AC214]:** Replace with d) the forecast half-hourly average Active Power Demand with generation netted out for the Network Operator's System (summatmed over all Connection Points) for the days of the forecast yearly NETS peak Demand as specified by The Company.

**Commented [PT(215R214)]:** Sub-group Accept

**Commented [SA216]:** The min date and times are to be shared with DNOs in Week 43 according to to allow them produce Week 2. To identify min forecast demand in Schedule 10C, we need to align with min data provided by NG. Is it still required to submit schedule 10C in Week 28? If yes, will NG provide min date and time in Week 17 as well ?

**Commented [AC217]:** See comments on 10 A and B, which are relevant here as well. The descriptions of 10C should be similar to 10B (rather than 10a).

There should be a new 10A schedule.

I've not commented further on this section.

**Commented [PT(218R217)]:** Sub-group Accept

**Commented [SA219]:** Is it maximum or minimum ?

**Commented [AC220]:** This should be a new post CIM Schedule

**Commented [PT(221R220)]:** Sub-group Accept

**Commented [AC222]:** Connection Point

**Commented [PT(223R222)]:** Sub-group reject

**Commented [AC224]:** Bold - defined term

**Commented [PT(225R224)]:** Sub-group Accept

**Commented [AC226]:** What does weather corrected mean? Its is defined in PC.A.4 - need to make sure this is included in PCG - or better still as a definition of weather corrected.

**Commented [PT(227R226)]:** Sub-group Accept

**Commented [AC228]:** ...with a forecast for the .....

**Commented [PT(229R228)]:** Sub-group Accept  
Financial Year to be bolded as defined terms

**Commented [AC230]:** ..Financial Year...

**Commented [PT(231R230)]:** Sub-group Accept

**Commented [VG232]:** Are these still appropriate?

**Commented [AC233]:** In the Schedule this is Public Lighting

**Commented [PT(234R233)]:** Sub-group Accept

**Commented [AC235]:** Is this information actually used by anyone?

**Commented [AC236]:** ...connection dates in....

**Commented [PT(237R236)]:** Sub-group Accept

Support for dynamic power system studies, including RMS dynamic stability type studies, is not required by the **Subtransmission PSM**.

PC.9.4.1.2 The scope of the **Network Operator's System** to be represented by a **Subtransmission PSM** shall include:

- a) all parts of the **Network Operator's System** operating at **Supergrid Voltage**;
- b) all parts of the **Network Operator's Subtransmission System** operating at a nominal voltage greater than 30kV;
- c) all parts of the **Network Operator's Subtransmission System** at any **Transmission Site** operating at a voltage of 30kV or less;
- d) **Network Operator's** assets (including transformers and switchgear) at substations connecting the **Network Operator's Subtransmission System** to a lower voltage;
- e) all parts of the **Network Operator's System** operating at the voltage level below the **Subtransmission System** which, under either intact network or **Planned Outage** conditions:
  - i. interconnects and operates in parallel between **Connection Points**; or
  - ii. interconnects busbars at a **Connection Point**, which are normally run as separate sections;
- f) the relevant assets in **Power Stations** connected to the **Network Operator's Subtransmission System**;
- g) aggregated representation of **Power Stations** connected to a voltage less than that of the **Subtransmission System**;
- h) any **OTSUA** connected to the **Network Operator's System**; and
- i) any parts of the **Offshore Transmission System** connected to the **Network Operator's System**.

For the avoidance of doubt, any assets owned or operated by a **Relevant Transmission Licensee** shall not be included in the **Subtransmission PSM**.

PC.9.4.1.3 The **Situation Data** of all **Subtransmission PSMs** shall reflect an intact system, with each switching device in its normal operational state.

PC.9.4.2 Components of the **Solved PSM**

PC.9.4.2.1 The **Solved PSM** has three main types of data:

- a) **Structural Data**, which represents the components of a **Network Operator's System**, including their capabilities and connectivity, at a specified date. The **Structural Data** of the **Solved PSM** describes the electrical characteristics of all relevant grid components within the scope set out in PC.9.4.1, including assets (for example overhead lines, underground cables, circuit breakers, switches, power transformers, reactive compensation equipment and similar equipment) as well as **Generators'** assets and the load connection points;
- b) **Situation Data**, which represents an operational state of the system, under specific conditions (i.e. **NETS peak** and **NETS minimum** as specified by **The Company**). The **Situation Data** of the **Solved PSM** describes the appropriate circuit breaker and/or switch positions, generation/load injections, and transformer tap positions etc.; and
- c) **Solution Data**, which represents the results of calculations executed using a coordinated set of **Structural Data** and **Situation Data**. The **Solution Data** of the **Solved PSM** includes both steady-state power flow calculation results (which include topology, voltage, and power flow data) and short circuit calculation results (which include short circuit power and current data).

PC.9.4.2.2 Structural Data

Commented [AC238]: Network Operator User System

Commented [BS239]: Will this be under normal operation?

Commented [BS240]: Does this cover 33kV feeders up to primary substations or are we reducing the network to BSPs?

Commented [AC241]: unbold

Commented [PT(242R241)]: Sub-group Accept

Commented [BS243]: Including Power Stations above 100MW?

Commented [BS244]: So CIM model provided should be reduced to DNO networks only.

Commented [AC245]: .... NETS peak demand and NETS minimum demand....

Commented [PT(246R245)]: Sub-group Accept



PC.9.4.2.2.1 All equipment in scope as set out in PC.9.4.1 shall be described by the **Structural Data** of the **Solved PSM**, including **Network Operator** assets, **Generators'** assets and the load connection points. Where the **Network Operator** and **The Company** agree, a **Solved PSM** can also contain additional details of the **Network Operator's System**.

Commented [AC247]: ..additional to what....

PC.9.4.2.2.2 The following assets, with their associated data, shall be modelled:

- a) Circuit breakers and/or switches that are required to facilitate network reconfiguration. For all circuit breakers and/or switches modelled, the supplied data shall be the data specified in PC.G.1, which includes information relating to any substation infrastructure where it limits the capability of the circuit breaker and/or switch. Alternatively, supplied circuit breaker and/or switch data may relate to the most restrictive equipment at that site;
- b) All transformers with their associated tap changers within the scope of the model. Supplied data shall be the data specified in PC.G.1;
- c) All circuits within the scope of the model. Supplied data shall be the data specified in PC.G.1;
- d) All reactive compensation assets, for example series compensators, shunt compensators and static VAR compensators, within the scope of the model. Supplied data shall be the data as specified in PC.G.1;
- e) All assets comprising an HVDC System within the scope of the model. Supplied data shall be the data specified in PC.G.1; and
- f) Any assets not specified above, but considered necessary as part of the Subtransmission PSM. Where the currently utilised data exchange specification does not support data about such assets, the data shall be exchanged by agreement.

- Commented [AC248]: ...by agreement between The Company and the relevant Network Operator.
- Commented [PT(249R248)]: Sub-group Accept
- Commented [AC250]: ...to the Subtransmission System.
- Commented [PT(251R250)]: Sub-group Accept
- Commented [AC252]: ...shall be an equivalent....
- Commented [PT(253R252)]: Sub-group Accept
- Commented [AC254]: unbold
- Commented [PT(255R254)]: Sub-group Accept
- Commented [AC256]: unbold
- Commented [PT(257R256)]: Sub-group Accept

PC.9.4.2.2.3 Each **Synchronous Power Generating Module** and **Power Park Module** in a **Power Station** shall be modelled:

- a) Where connected to the Subtransmission System, individually, at its actual grid location, accompanied by information regarding the substation assets via which it is connected to the grid. In the case of each Power Park Module, the representation is an equivalent; and
- b) Where connected at a voltage below that of the Subtransmission System, as an aggregated equivalent, connected to the relevant substation busbar in the Subtransmission PSM, grouped by Aggregated Energy Source (as defined in PC.G.8.2).

Commented [BS258]: This is new and we need to prepare our models. Any guidance how to model aggregated generators in terms of Fault level contributions?  
Formatted: Font: Bold

Supplied data shall be the data as specified in PC.G.1.

The sum of the generation described in (a) and (b) above should equal the sum of generation provided in 21G and 21H.

Commented [AC259]: ...in a) and b) above.....  
Commented [PT(260R259)]: Sub-group Accept

Where **The Company** reasonably requires it, the **Network Operator** shall supply individual modelling of specific generation or storage connected at a voltage level below the Subtransmission System.

Commented [AC261]: I don't think it should be equal to it because it all depends on the connection dates compared with the data freeze dates of the models.  
I get the intent though, so suggest:  
...above should be consistent with the generation provided in .....

PC.9.4.2.2.4 Load shall be modelled according to the following guidelines:

- a) Each load connected to the Subtransmission System shall be represented as an equivalent, together with any associated substation assets, at the relevant Connection Point, recognising the existence of the following:
  - i. Identifiable large motors;
  - ii. Any Synchronous Power Generating Modules or Power Park Modules in a Non-Embedded Customer's site; and
  - iii. Asynchronous motors, that are not individually represented, which form part of the general load, and which are modelled, in accordance with EREC G74 requirements, as a suitable equivalent motor.

- Commented [PT(262R261)]: Sub-group Accept  
Add- "Schedules" in front of 21G and 21H  
Formatted: Highlight
- Formatted: Highlight
- Formatted: Highlight
- Commented [VG263]: ....Schedules 21G and 21H.
- Commented [AC264]: ...in Data Registration Code Schedules 21.....
- Commented [PT(265R264)]: Sub-group Accept  
Formatted: Highlight
- Commented [AC266]: Storage is generation  
....specific generation connected.....
- Commented [PT(267R266)]: Sub-group Accept
- Commented [AC268]: These are more than guidelines  
...modelled as follows:
- Commented [PT(269R268)]: Sub-group Accept

b) All load connected at a voltage below that of the **Subtransmission System** shall be represented as aggregated load equivalents, which are modelled connected to the relevant substation busbar in the **Subtransmission PSM**. The load object shall be modelled as per EREC G74 requirements.

Supplied data shall be the data specified in PC.G.1.

PC.9.4.2.2.5 Relevant equipment shall have nominal voltage ratings and nominal current or **apparent power** ratings. Supplied data shall be the data specified in PC.G.1.

Normal capability/operational ratings, including seasonal and post-fault ratings, shall be stated according to the following guidelines:

a) All busbars and connection nodes shall have operational voltage **limits**.

b) All circuits and transformers shall have current or **apparent power** operational ratings. Transformers shall have both normal direction flow ratings and reverse flow ratings.

The supplied normal capability/operational limits and ratings data shall be as specified in PC.G.1.

PC.9.4.2.2.6 At the **Network Operator's** discretion the geospatial location of substations and lines may be modelled.

PC.9.4.2.2.7 The **Structural Data** of the **Subtransmission PSM** shall connect to the **Structural Data** of **PSMs** of adjacent **Systems** by means of **PSM Interface Nodes**, which are points that represent a modelling boundary either side of which different parties are responsible for data. The grid locations of **PSM Interface Nodes**, between **Network Operators** and **The Company**, shall be agreed by the parties based on the ownership boundaries detailed in Appendix A of the relevant Bilateral Agreements. The grid locations of **PSM Interface Nodes**, between **Network Operators**, shall be agreed by the parties. Additional detail on the application of **PSM Interface Nodes** is specified in PC.G.3.

PC.9.4.2.3 Situation Data

PC.9.4.2.3.1 **Situation Data** refers to a specific set of **Structural Data**. The **Solved PSMs** required by PC.9.3.2.1 and PC.9.3.3.1 have **Situation Data** which reflect to a specific **NETS** condition that has been adjusted to fit with the underlying **Structural Data** as of the **Data Freeze Date**.

PC.9.4.2.3.2 **Situation Data** correlating to the prescribed grid condition shall be provided for each relevant component present in the **Structural Data** of the **Solved PSM** as specified in PC.G.1.

PC.9.4.2.4 Solution Data

PC.9.4.2.4.1 Power flow **Solution Data** shall describe the output resulting from a successful power flow calculation based on each specified set of **Situation Data**, and its related **Structural Data**, as input.

PC.9.4.2.4.2 Short circuit **Solution Data** shall describe the output resulting from a specific short circuit calculation based on each specified set of **Situation Data**, and its related **Structural Data**, as input.

PC.9.4.2.5 Diagram Data

The **Solved PSM** shall include diagrams as described in PC.G.1.6.

PC.9.5 Assessment of Site Compliance

PC.9.5.1 The process that ensures the compliance and operability at **Connection Points** during the maintenance of **Transmission Interface Circuits** and the obligations of **Network Operators** in that process are detailed in PC.G.7.

PC.9.5.3 **Network Operators** shall, in calendar week 28, submit to **The Company** the data detailed in PC.G.7.1.7.

PC.9.6 Confidentiality and Sharing

- Commented [AC270]: ...load equivalents connected to the .....
- Commented [PT(271R270)]: Sub-group Accept
- Commented [AC272]: Missing full stop
- Commented [PT(273R272)]: Sub-group Accept
- Commented [VG274]: Apparent Power (? - it is a defined term)
- Commented [AC275]: ...limits; and
- Commented [PT(276R275)]: Sub-group Accept
- Commented [VG277]: As above
- Commented [AC278]: ??
- ...and lines may be included in the **Structural Data**.
- Commented [PT(279R278)]: Sub-group Accept
- Commented [AC280]: The interface nodes are not between NOs and ESO - but between assets owned/operated by those parties ie where they have modelling responsibility:  
Suggest:  
The grid locations of **PSM Interface Nodes**, relevant to **Network Operators** and **The Company**, shall be agreed by the parties based on the ownership boundaries detailed in Appendix A of the relevant Bilateral Agreements. The grid locations of **PSM Interface Nodes** relevant to multiple **Network Operators**, shall be agreed by the parties. Additional detail on the application of **PSM Interface Nodes** is specified in PC.G.3.  
  
OR as per PC.10:  
The grid locations of **PSM Interface Nodes**, shall be agreed by the parties based on the ownership boundaries detailed in Appendix A of the relevant Bilateral Agreements.
- Commented [PT(281R280)]: Sub-group Accept  
Align text with that from PC10 to replace text:  
The grid locations of **PSM Interface Nodes**, between **Network Operators** and **The Company**, shall be agreed by the parties based on the ownership boundaries detailed in Appendix A of the relevant Bilateral Agreements. The grid locations of **PSM** ...
- Commented [AC282]: ..which reflect to a ??
- Commented [PT(283R282)]: Sub-group Accept  
Change to - which represents ...
- Commented [AC284]: I'm sure this is correct but is a bit cryptic. Might it be possible to expand on this (or point to ...
- Commented [PT(285R284)]: Sub-group - delete "underlying" ...
- Commented [AC286]: unbold
- Commented [PT(287R286)]: Sub-group Accept
- Commented [AC288]: There is also material in PC.7
- Commented [PT(289R288)]: Sub-group Accept confirm PC.7 doesn't apply post CIM.
- Commented [AC290]: Have I unintentionally deleted PC.9.5.2
- Commented [PT(291R290)]: Sub-group Accept - renumber
- Commented [AC292]: bold
- Commented [PT(293R292)]: Sub-group Accept
- Commented [AC294]: Check reference
- Commented [PT(295R294)]: Sub-group Accept - reference to be corrected
- Commented [AC296]: unbold
- Commented [PT(297R296)]: Sub-group Accept
- Formatted: Font: Bold

- PC.9.6.1 The models, supporting documentation and associated data submitted to **Network Operators** pursuant to PC.10 are provided in order that **Network Operators** may carry out their responsibilities to meet their **Electricity Distribution Licence** obligations to develop an efficient, coordinated and economical **Network Operator System**. In that regard, a **Network Operator** may share such models, supporting document and associated data with companies/contractors employed by the **Network Operator** to carry out those responsibilities.
- PC.9.6.2 A suitable secure platform, to support the physical exchange of information submitted by **Network Operators** pursuant to PC.9 and **The Company** pursuant to PC.10, shall be established by **The Company**.
- PC.9.6.3 A system shall be agreed and implemented by **The Company** and **Network Operators** to support the creation, editing, storage and retrieval by appropriate parties, of data related to the **PSM Interface Nodes**.

Commented [VG298]: User System?

Commented [AC299]: Delete 'In that regard, a'

Commented [PT(300R299)]: Sub-group Accept  
Replace with A **Network Operator**....

Commented [AC301]: Add full stop

Commented [PT(302R301)]: Sub-group Accept

Commented [AC303]: Is it clear which party should take the lead on this - the ESO? Perhaps there is something in PC10?

PC.10 SUBMISSION OF SYSTEM MODELS AND INFORMATION BY THE COMPANY TO NETWORK OPERATORS

PC.10.1 General

PC.10.1.1 PC.10 details the **minimum** planning data to be submitted by **The Company to Network Operators**.

**Commented [AC304]:** Delete - it specifies all the planning data if only because there are provisions providing more data where reasonably required etc.

PC.10.1.2 Compliance with the data submission requirements within PC.10 shall only apply after the **PSM Implementation Date**.

**Commented [PT(305R304)]:** Sub-group Accept

PC.10.1.3 **The Company** shall use reasonable endeavours to obtain all applicable information required by PC.10 from any **User** connected to the **NETS** and from **Relevant Transmission Licensees**, such that the information provided is the best information available at the time of submission.

**Commented [VG306]:** Ok with the action as it is on the ESO but this will need to be reflected into the STC as TOs do not have any obligations under the Grid Code

PC.10.2 Purpose

PC.10.2.1 The purpose of the data submission set out in PC.10 is to ensure that **The Company** provide sufficient information to **Network Operators** so that they:

- a) Have models of the **NETS** which can be used in the creation of the **Network Operator's** own system model;
- b) Can establish that their distribution system complies with relevant technical standards; and
- c) Are aware of proposed changes to the **NETS** and connections to the **NETS** that may have an impact on the distribution system, hence facilitating a distribution impact assessment.

PC.10.3 Submissions

PC.10.3.1 Submissions by **The Company to Network Operators** include:

- c) Routine submissions each year in calendar week 12 and calendar week 38. These are described in PC.10.3.2 and PC.10.3.3 respectively. A diagram illustrating the coordination of submissions between the **Network Operators** and **The Company** is provided in PC.G.9: and
- d) Additional supplementary information when **The Company** reasonably believes that a new or modified **User** connection, or proposed alteration to the **NETS** may have an impact on a **Network Operator's System**, or on request by the **Network Operator**. This information, together with the routine submissions, shall provide sufficient data so that the **Network Operator** can assess its impact. The supplementary information is described in PC.10.3.4.

**Commented [AC307]:** Bullet should be a) b) etc

**Commented [PT(308R307)]:** Sub-group Accept

**Commented [VG309]:** As this is in PC10 would it be better to reword as 'between The Company and Network Operators' to maintain the logical flow of NESO to NO.

Nothing shall prevent the submission of data detailed in PC.10 at additional points during the year were agreed between **The Company** and the **Network Operator(s)**.

At a **Network Operator's** reasonable request and where agreed by **The Company**, additional data on the **NETS** beyond that described in PC.10 shall be provided by **The Company**, for example dynamic model data or more detailed **HVDC System** models.

**Commented [AC310]:** ...can assess the impact of such a change, modification or alteration.

**Commented [PT(311R310)]:** Sub-group Accept

PC.10.3.1.1 **The Company** shall use the information in the submission from **Network Operators** in calendar week 2 and calendar week 28:

- a) **When establishing the forecast dates and times of the summer and winter Structural Data** referred to in PC.10.3.2 and PC.10.3.3 respectively. Those dates shall be provided in the **PSM Scenario Document**. The **Situation Data** of the demand scenarios reflecting those dates and times shall be estimated by **The Company** based on historical information and forecasts of future demand and generation; and
- b) To derive, in a reasonable manner, a cohesive forecast to be used in preparing **Forecast Demand** information in the **Electricity Ten Year Statement** and for use in **The Company's Operational Planning**. If any **Network Operator** believes that the cohesive forecast **Demand** information in the **Electricity Ten Year Statement** does

**Commented [AC312]:** Suggested tweak for clarity.  
When establishing the forecast dates and times of the summer and winter **Structural Data to be used in the models** referred to in PC.10.3.2 and PC.10.3.3 respectively

**Commented [PT(313R312)]:** Sub-group Accept  
Change- to be used in the **Solved PSMs**...

**Commented [AC314]:** Not a defined term

**Commented [PT(315R314)]:** Sub-group Accept  
Un bold and un capitalise

**Commented [AC316]:** Does the ESO share the ETYS with an expectation that the DNOs will review the document and identify any concerns? This reads as though there is an obligation on the DNOs to do this - I don't believe that there is.

**Commented [AC317]:** Check the defined term

**Commented [PT(318R317)]:** Sub-group Accept  
Bold - Electricity

not reflect its assumptions on Demand, it should contact The Company to explain its concerns and may require The Company, on reasonable request, to discuss these forecasts. In the absence of such expressions, The Company will assume that Network Operators concur with The Company's cohesive forecast.

PC.10.3.1.2 The Company shall notify the Network Operators, in calendar week 43, of:

a) The date and time of the preceding NETS summer minimum demand.

PC.10.3.1.3 The Company shall notify the Network Operators, in calendar week 17, of:

a) The date and time of the preceding NETS winter peak demand; and

b) For the current Financial Year and for each of the following nine Financial Years, the forecast date and time of:

i. The NETS winter peak demand; and

ii. The NETS summer minimum demand.

PC.10.3.2 The data submitted in calendar week 12 shall comprise:

PC.10.3.2.1 A set of Solved PSMs of the NETS which conform to the NETS PSM requirements as described in PC.10.4.2. Each Solved PSM shall be based on the same Structural Data, referred to as summer Structural Data, which reflects The Company's best view of the System as it is expected to be at the next summer minimum and which contains asset characteristics sufficient to support both power flow and short circuit calculations. The Solved PSMs are:

f) A minimum demand Solved PSM which includes:

i. Summer Structural Data;

ii. Situation Data corresponding to the date and time of the forecast NETS minimum demand between calendar weeks 13 and 43;

iii. Solution Data resulting from a power flow calculation executed on the Structural Data and Situation Data; and

iv. Diagram Layout Data describing diagrams of Structural and a subset of Situational Data [PC.G.2.5.5].

g) A minimum daylight demand Solved PSM which includes:

i. Summer Structural Data;

ii. Situation Data corresponding to the date and time of the forecast NETS minimum demand during the period 10:00 to 16:00 between calendar weeks 13 and 43;

iii. Solution Data resulting from a power flow calculation executed on the Structural Data and Situation Data; and

iv. Diagram Layout Data describing diagrams of Structural and a subset of Situational Data [PC.G.2.5.5].

h) A low power transfer Solved PSM which includes:

i. Summer Structural Data;

ii. Situation Data corresponding to the date and time of a forecast NETS low power transfer between calendar weeks 13 and 43;

iii. Solution Data resulting from a power flow calculation executed on the Structural Data and Situation Data; and

iv. Diagram Layout Data describing diagrams of Structural and a subset of Situational Data [PC.G.2.5.5].

i) A minimum fault level Solved PSM which includes:

i. Summer Structural Data;

ii. Situation Data, including demand short circuit contributions, corresponding to the forecast date and time of the estimated NETS minimum fault level between

Commented [AC319]: .....it should contact The Company to explain its concerns and may request that The Company explain the rationale underpinning these forecasts.

Commented [PT(320R319)]: Sub-group Accept

Commented [AC321]: I don't think this is a reasonable statement. All the ESO can assume is that no issues have been identified - but because the DNO has no obligation to check then the ESO can't take silence as assent.

I can see that this is a reasonable think for the ESO to assume - it jus should be in the GCode.

Delete

Commented [PT(322R321)]: Sub-group Accept  
Delete last sentence in claus

Commented [AC323]: ..of the preceding summer NETS minimum demand.

It's the summer that is preceding.

Commented [PT(324R323)]: Sub-group Accept  
Change - preceding to most recent summer NETS minimum demand.

Commented [AC325]: ...preceding winter NETS peak demand

Commented [PT(326R325)]: Sub-group Accept  
Change - preceding to most recent summer NETS minimum demand.

Commented [AC327]: ...the date and time of the forthcoming summer minimum NETS demand and which....

Commented [AC328]: The set of Solved PSMs include:

Commented [AC329]: Start at a) rather than f)

Commented [PT(330R329)]: Sub-group Accept

Commented [AC331]: unbold

Commented [PT(332R331)]: Sub-group Accept

Commented [VG333]: Structural Data

Commented [AC334]: unbold

Commented [PT(335R334)]: Sub-group Accept

Commented [VG336]: Situation

Commented [AC337]: ...as described in PC.G.2.5.5.

I couldn't find 2.5.5, so this may not be the correct reference.

Commented [AC338]: unbold

Commented [PT(339R338)]: Sub-group Accept

Commented [VG340]: Structural Data

Commented [AC341]: ditto

Commented [VG342]: Structural Data

Commented [VG343]: Situation

Commented [AC344]: ditto

Commented [AC345]: unbold

Commented [PT(346R345)]: Sub-group Accept

calendar weeks 13 and 43;

iii. **Solution Data** resulting from a short circuit calculation executed on the **Structural Data** and **Situation Data**; and

iv. **Diagram Layout Data** describing diagrams of **Structural** and a subset of **Situational Data** PC.G.2.5.5.

Where two or more of the **Solved PSM** defined under PC.10.3.2.1 are identical, only a single **Solved PSM** need be provided for these conditions. The conditions represented by such a single **Solved PSM** shall be noted in the **PSM Scenario Document**.

PC.10.3.2.2 A **PSM Scenario Document** and a **PSM Change Document**, conformant to the requirements described in PC.G.5 and PC.G.6, respectively.

PC.10.3.2.3 A collection of individual **PSDMs** describing new or modified **User** connections or proposed alterations to the **NETS** that **The Company** reasonably believes may have a material impact on this submission's set of **Solved PSMs**. Individual **PSDMs** shall be supplied for:

a) each new or modified generation and/or load connection not represented in the **Summer** **Structural Data** where the relevant customer has accepted a connection offer from **The Company** to connect to the **NETS**; and

b) each authorised **NETS** reinforcement, asset replacement scheme or similar not included in the **Summer** **Structural Data**.

PC.10.3.3 The data submitted in calendar week 38 shall comprise:

PC.10.3.3.1 A set of **Solved PSMs** of the **NETS** which conform to the **NETS PSM** requirements as described in PC.10.4.2. Each **Solved PSM** shall be based on the same **Structural Data**, referred to as winter **Structural Data**, which reflects **The Company's** best view of the **System** as it is expected to be at the next winter peak and which contains asset characteristics sufficient to support both power flow and short circuit calculations. The **Solved PSMs** are:

a) A peak demand **Solved PSM** which includes:

i. Winter **Structural Data**;

ii. **Situation Data** corresponding to the date and time of the forecast **NETS** peak demand between calendar weeks 43 and 13;

iii. **Solution Data** resulting from a power flow calculation executed on the **Structural Data** and **Situation Data**; and

iv. **Diagram Layout Data** describing diagrams of **Structural** and a subset of **Situational Data** PC.G.2.5.5.

b) A high power transfer **Solved PSM** which includes:

i. Winter **Structural Data**;

ii. **Situation Data** corresponding to the date and time of a forecast **NETS** high power transfer between calendar weeks 43 and 13;

iii. **Solution Data** resulting from a power flow calculation executed on the **Structural Data** and **Situation Data**; and

iv. **Diagram Layout Data** describing diagrams of **Structural** and a subset of **Situational Data** PC.G.2.5.5.

c) A maximum fault level **Solved PSM** which includes:

i. Winter **Structural Data**;

ii. **Situation Data** based on **Situation Data** of the maximum demand **Solved PSM**, defined under PC.10.3.3.1 a), and additionally includes:

a. Demand short circuit contributions; and

b. All generation connected and energised to the **System**;

- Commented [VG347]: This isn't a proposed defined term in the G&D - should it be?
- Commented [VG348]: Structural Data
- Commented [VG349]: Situation Data
- Commented [AC350]: ditto
- Commented [AC351]: ..those...
- Commented [AC352]: ...described...

- Commented [AC353]: Should the materiality assessment be based on the implications for the Solved PSM or the materiality of the impact on a Users System? - the latter
- Commented [AC354]: Where material, individual .....
- Commented [AC355]: Lower case s
- Commented [PT(356R355)]: Sub-group Accept
- Commented [SM357]: Subgroup suggests "summer"
- Commented [AC358]: Lower case s
- Commented [PT(359R358)]: Sub-group Accept Change to - summer
- Commented [SM360]: Subgroup suggests "summer"
- Commented [AC361]: .....at the date and time of the forthcoming winter peak NETS demand and which....
- Commented [AC362]: The set of **Solved PSMs** include:
- Commented [AC363]: unbold
- Commented [PT(364R363)]: Sub-group Accept
- Commented [VG365]: Structural Data
- Commented [AC366]: unbold
- Commented [PT(367R366)]: Sub-group Accept
- Commented [VG368]: Situation
- Commented [AC369]: Some words missing here. Check reference
- Commented [AC370]: unbold
- Commented [PT(371R370)]: Sub-group Accept
- Commented [VG372]: This is a proposed define term - should it be?
- Commented [VG373]: unbold
- Commented [PT(374)]: Sub-group un bold
- Commented [VG375]: Structural Data
- Commented [VG376]: unbold
- Commented [PT(377)]: Sub-group un bold
- Commented [VG378]: Situation
- Commented [PT(379)]: Sub-group check reference
- Commented [AC380]: Ditto previous comments on this clause
- Commented [AC381]: Delete 'includes' as its unnecessary
- Commented [AC382]: Short circuit contribution from demand; and
- Commented [AC383]: All generation connected to the **System** and energised.

Solution Data reflecting the theoretical maximum NETS bus fault levels which results from short circuit calculations executed on the Structural Data and Situation Data; and

iii. Diagram Layout Data describing diagrams of Structural and a subset of Situational Data [PC.G.2.5.5].

Where two or more of the Solved PSM defined under PC.10.3.3.1 are identical, only a single Solved PSM need be provided for these conditions. The conditions represented by such a single Solved PSM shall be noted in the PSM Scenario Document.

PC.10.3.3.2 A PSM Scenario Document and a PSM Change Document, conformant to the requirements described in PC.G.5 and PC.G.6, respectively.

PC.10.3.3.3 A collection of individual PSDMs describing new or modified User connections or proposed alterations to the NETS that The Company reasonably believes may have a material impact on this submission's set of Solved PSMs. Individual PSDMs shall be supplied for:

- a) Each new or modified generation and/or load connection not represented in the Winter/Winter/Winter Structural Data where the relevant customer has accepted a connection offer from The Company to connect to the NETS; and
- b) Each authorised NETS reinforcement, asset replacement scheme or similar not included in the Winter/Winter/Winter Structural Data.

PC.10.3.4 The supplementary information required under the conditions outlined in PC.10.3.1 b) shall comprise:

- a) A PSDM describing the new or modified User connection or proposed alteration to the NETS; and
- b) A representation of the NETS and its User connections at the time the new or modified User connection, or proposed NETS alteration is planned to be commissioned, supplied in the form of a Structural Data PSM or Solved PSM and PSDMs as required, where:
  - i. The PSM reflects the time of commissioning; or
  - ii. The PSM reflects any earlier time supplemented by PSDMs sufficient to enable updating of the PSM to reflect the time of commissioning.

PC.10.4 The Company's NETS PSM

PC.10.4.1 Scope

PC.10.4.1.1 The NETS PSM is intended to provide data sufficient for power system studies which support the activities outlined in PC.10.2.1, including:

- c) power/power/power flow calculations; and
- d) short circuit calculations in accordance with EREC G74.

Support for dynamic power system studies, including RMS dynamic stability type studies, is not required by the NETS PSM.

PC.10.4.1.2 The scope of the NETS PSM includes the entirety of the NETS, including any HVDC Systems, together with representation of Users' Systems, other than Network Operators User Systems, connected to the NETS.

PC.10.4.1.3 The Structural Data of the NETS PSM shall include:

- j) all assets forming the NETS including transformers and switchgear at substations connecting Users to the NETS;
- k) the relevant assets in Power Stations directly connected to the NETS;
- l) the relevant assets of Non-Embedded Customers, aggregated representation of Power Stations and the load shall be modelled as per EREC G74 requirements; and
- m) any OTSUA connected to the NETS.

For the avoidance of doubt, any assets owned or operated by a Network Operator shall not be included in the NETS PSM.

- Commented [AC384]: Should this be iii ?
- Commented [PT(385R384)]: Sub-group Accept
- Commented [AC386]: ...busbar....?
- Commented [AC387]: Should this be iv ?
- Commented [PT(388R387)]: Sub-group Accept
- Commented [PT(389)]: Sub-group Un bold
- Commented [VG390]: Structural Data
- Commented [VG391]: unbold
- Commented [PT(392)]: Sub-group un bold text
- Commented [VG393]: Situation
- Commented [PT(394)]: Sub-group check reference
- Commented [AC395]: Ditto previous comments on similar clauses
- Commented [AC396]: ....PSMs...
- Commented [PT(397R396)]: Sub-group Accept
- Commented [AC398]: ...be described in...
- Commented [VG399]: AS per PC.9 what is a PSDM?
- Commented [AC400]: Should the materiality assessment be based on the implications for the Solved PSM or the materiality of the impact on a Users System? - the latter
- Commented [AC401]: unbold
- Commented [PT(402R401)]: Sub-group Accept
- Commented [AC403]: Where material, individual....
- Commented [AC404]: Lower case w
- Commented [PT(405R404)]: Sub-group Accept
- Commented [AC406]: Lower case w
- Commented [PT(407R406)]: Sub-group Accept

- Commented [AC408]: The NETS PSMs are....
- Commented [PT(409R408)]: Sub-group Accept
- Commented [AC410]: Restart from a) rather than c)
- Commented [PT(411R410)]: Sub-group Accept

- Commented [AC412]: ...in the NETS PSM.
- Commented [PT(413R412)]: Sub-group Accept
- Commented [AC414]: Generally we've used the term Network Operators System in PC9 and PC10 - although it could be argued that the correct (although more confusing term) Network Operators User System should be used. Consistency.

- Commented [AC415]: Restart bullets from a)
- Commented [PT(416R415)]: Sub-group Accept
- Commented [AC417]: I think this is a separate bullet
- Commented [AC418]: Do we need to clarify that by Power Station, we mean a Power Station connected to the NETS rather than embedded?
- Commented [AC419]: It would be good to clarify if this meant the generation at Power Stations, the load at Power Stations and the load at Non-Embedded Customers shall be modelled as per G74.

PC.10.4.1.4 The **Situation Data** of all **NETS PSMs** shall reflect an intact system, with each switching device in its normal operational state.

#### PC.10.4.2 Components of the **Solved PSM**

PC.10.4.2.1 The **Solved PSM** has three main types of data:

- d) **Structural Data**, which represents the equipment forming the **NETS**, including their capabilities and connectivity, at a specified date. The **Structural Data** of the **Solved PSM** describes the electrical characteristics of all relevant **NETS** equipment within the scope set out in PC.10.4.1, including assets (for example overhead lines, underground cables, circuit breakers, switches, power transformers, reactive compensation equipment, quadrature boosters, and similar equipment) as well as **Generators'** assets and the load connection points;
- e) **Situation Data**, which represents an operational state of the **system** under specific conditions (i.e. **NETS** peak and **NETS** minimum as specified by **The Company**). The **Situation Data** of the **Solved PSM** describes the appropriate circuit breaker and/or switch positions, generation/load injections, and transformer tap positions etc.; and
- f) **Solution Data**, which represents the results of calculations executed using a coordinated set of **Structural Data** and **Situation Data**. The **Solution Data** of the **Solved PSM** can represent either steady-state power flow calculation results (which include topology, voltage, and power flow data) or short circuit calculation results (which include short circuit power and current data).

#### PC.10.4.2.2 Structural Data

PC.10.4.2.2.1 All equipment in scope as set out in PC.10.4.1 shall be described by the **Structural Data** of the **Solved PSM**.

PC.10.4.2.2.2 The following assets, with their associated data, shall be modelled:

- g) All circuit breakers within the scope of the model and switches that are required to facilitate system reconfiguration. For all circuit breakers and/or switches modelled, the supplied data shall be the data specified in PC.G.1, which includes information relating to any substation infrastructure where it limits the capability of the circuit breaker and/or switch. Alternatively, supplied circuit breaker and/or switch data may relate to the most restrictive equipment at that site;
- h) All transformers (including quadrature boosters) with their associated tap changers within the scope of the model. Supplied data shall be the data specified in PC.G.1;
- i) All circuits within the scope of the model. Supplied data shall be the data specified in PC.G.1;
- j) All reactive compensation assets, for example series compensators, shunt compensators and static VAR compensators, within the scope of the model. Supplied data shall be the data specified in PC.G.1;
- k) All assets comprising an **HVDC System** within the scope of the model. Supplied data shall be the data specified in PC.G.1.  
  
In relation to **HVDC Systems** where not all the **HVDC Interface Points** connect to the **NETS**, the model may include an equivalent representation of the **HVDC Systems**. Reference to the operation of these equivalents shall be made in the **PSM Scenario Document**; and
- l) Any assets not specified above, but considered necessary as part of the **NETS PSM**. Where the currently utilised data exchange specification does not support data about such assets, the data shall be exchanged by agreement.

PC.10.4.2.2.3 **Synchronous Power Generating Modules** in **Power Stations** shall be individually represented, and accompanied by information regarding the substation assets, at the relevant **Connection Point**. **Power Park Modules** in **Power Stations** shall be represented as an equivalent, together with any associated substation assets, at the relevant **Connection Point**. Supplied data shall be the data specified in PC.G.1.

Commented [AC420]: Restart at a)

Commented [PT(421R420)]: Sub-group Accept

Commented [AC422]: Agreed, but includes non NETS equipment as well - do we need to clarify this as per the second part of the sentence?

Commented [AC423]: ...as well as relevant **Generators'** assets and relevant **Non-Embedded Customers'** assets.

Is reference to the load connection points relevant?

Commented [AC424]: Do we mean ...of the **System**...?

Commented [PT(425R424)]: Sub-group Accept

Commented [AC426]: Restart at a)

Commented [PT(427R426)]: Sub-group Accept

Commented [AC428]: ...infrastructure which limits the....

Commented [AC429]: ...**System**. singular

Commented [AC430]: Just wondered if we meant :  
Where the current **CIM Standard** does not....

Commented [AC431]: ...by agreement between **The Company** and the relevant **Network Operator**.

Commented [AC432]: Do we need to clarify that by Power Station, we mean a Power Station connected to the NETS rather than embedded?

...in directly connected **Power Stations** shall....

Commented [AC433]: unbold

Commented [PT(434R433)]: Sub-group Accept

Commented [AC435]: ditto

Commented [AC436]: unbold

Commented [PT(437R436)]: Sub-group Accept



PC.10.4.2.2.4 **Non-Embedded Customer's** assets shall be represented as an equivalent, together with any associated substation assets, at the relevant **Connection Point**, recognising the existence of the following:

- a) Identifiable large motors;
- b) Any **Synchronous Power Generating Modules** or **Power Park Modules** in a **Non-Embedded Customer's** site; and
- c) Asynchronous motors, that are not individually represented, which form part of the general load, and which are modelled, in accordance with EREC G74 requirements, as a suitable equivalent motor.

Supplied data shall be the data specified in PC.G.1

PC.10.4.2.2.5 Relevant equipment shall have nominal voltage ratings and nominal current or **apparent power** ratings. Supplied data shall be the data specified in PC.G.1.

Normal capability/operational ratings, including seasonal and post-fault ratings, shall be stated according to the following guidelines:

- a) All busbars and connection nodes shall have operational voltage limits.
- b) All circuits and transformers shall have current or apparent power operational ratings. Transformers shall have both normal direction flow ratings and reverse flow ratings.

The supplied normal capability/operational limits and ratings data shall be as specified in PC.G.1.

PC.10.4.2.2.6 At **The Company's** discretion the geospatial location of substations and lines may be modelled.

PC.10.4.2.2.7 The **Structural Data** of the **NETS PSM** shall connect to the **Structural Data** of **Subtransmission PSMs** by means of **PSM Interface Nodes**, which are points that represent a modelling boundary either side of which different parties are responsible for data. The grid locations of **PSM Interface Nodes** shall be agreed by the relevant parties based on the ownership boundaries detailed in Appendix A of the relevant Bilateral Agreements. Additional detail on the application of **PSM Interface Nodes** is specified in PC.G.3.

PC.10.4.2.3 Situation Data

PC.10.4.2.3.1 Both the summer and winter **Structural Data** sets shall have one or more sets of related **Situation Data** reflecting each of the forecast operational conditions set out in PC.10.3.2.1 and PC.10.3.3.1.

PC.10.4.2.3.2 **Situation Data** correlating to the prescribed **grid condition** shall be provided for each relevant component present in the **Structural Data** of the **Solved PSM** as specified in PC.G.1.

PC.10.4.2.4 Solution Data

PC.10.4.2.4.1 Power flow **Solution Data** shall describe the output resulting from a successful power flow calculation based on each specified set of **Situation Data**, and its related **Structural Data**, as input.

PC.10.4.2.4.2 Short circuit **Solution Data** shall describe the output resulting from a specific short circuit calculation based on each specified set of **Situation Data**, and its related **Structural Data**, as input.

PC.10.4.2.5 Diagram Data

The **Solved PSM** shall include diagrams as described in PC.G.1.6.

PC.10.5 Assessment of Site Compliance

PC.10.5.1 The process to ensure the compliance and operability at **Connection Points** during the maintenance of **Transmission Interface Circuit** and the obligations of **The Company** in that process are detailed in PC.G.7.

Commented [VG438]: Apparent Power

Commented [AC439]: ...and lines may be included in the Structural Data.

Commented [AC440]: ..NETS condition...?

Commented [AC441]: unbold

Commented [PT(442R441)]: Sub-group Accept

Commented [AC443]: There is also material in PC.7

PC.10.5.2 **The Company** shall, no later than calendar week 7 of each year, submit in writing to the **Network Operators**, the information detailed in [PC.G.7.1.2](#)

PC.10.5.3 **The Company** shall notify **The Authority**, where an **Access Period** is amended pursuant to [PC.G.7.1.6](#)

PC.10.5.4 Following the submission of data by a **Network Operator** by calendar week 28 of each year, **The Company** shall, by calendar week 6 of the following year, submit in writing to the **Network Operator**, the assessment results detailed in [PC.G.7.1.9](#)

PC.10.6 Confidentiality and Sharing

PC.10.6.1 The models, supporting documentation and associated data submitted to **The Company** pursuant to PC.9 are provided in order that **The Company** and **Transmission Licensees** may carry out their responsibilities to meet their **Electricity Transmission Licence obligations** to develop efficient, coordinated and economical **NETS** and **Transmission Systems**. In regards, **a** **The Company** and **Transmission Licensees** may share such models, supporting document and associated data with companies/contractors employed by **The Company** and **Transmission Licensees** to carry out those responsibilities.

PC.10.6.2 A suitable secure platform shall be agreed and implemented by **The Company** and **Network Operators** to support the physical exchange of information submitted by **Network Operators** and **The Company**.

PC.10.6.3 A system shall be agreed and implemented by **The Company** and **Network Operators** to support the creation, editing, storage and retrieval by appropriate parties, of data related to the **PSM Interface Nodes**.

- Commented [AC444]: PC.G.7.1
- Commented [AC445]: Missing full stop
- Commented [PT(446R445)]: Sub-group Accept
- Commented [AC447]: PC.G.7.6
- Commented [AC448]: Check reference
- Commented [AC449]: Missing full stop
- Commented [PT(450R449)]: Sub-group Accept
- Commented [AC451]: unbold
- Commented [PT(452R451)]: Sub-group Accept
- Commented [VG453]: Need to reflect the new System Operator licence.
- Commented [AC454]: unbold
- Commented [PT(455R454)]: Sub-group Accept
- Commented [VG456]: *an efficient....*
- Commented [VG457]: Delete 'a'
- Commented [AC458]: Delete 'In regards, a'
- Commented [AC459]: unbold
- Commented [PT(460R459)]: Sub-group Accept
- Commented [AC461]: Is it clear which party should take the lead on this - the ESO is implied in PC.9.6.2
- A suitable secure platform shall be agreed by **The Company** and **Network Operators** and implemented by **The Company** to support the physical exchange of information submitted by **Network Operators** and **The Company**.
- Commented [AC462]: Is it clear which party should take the lead on this

## APPENDIX A - PLANNING DATA REQUIREMENTS

### PC.A.1 INTRODUCTION

PC.A.1.1 The Appendix specifies data requirements to be submitted to **The Company** by **Users**, and in certain circumstances to **Users** by **The Company**.

### PC.A.1.2 Submissions by Users

- (a) Planning data submissions by **Users** shall be:
- (i) with respect to each of the seven succeeding **Financial Years** (other than in the case of **Registered Data** which will reflect the current position and data relating to **Demand** forecasts which relates also to the current year);
  - (ii) provided by **Users** in connection with a **CUSC Contract** (PC.4.1, PC.4.4 and PC.4.5 refer);
  - (iii) provided by **Users** on a routine annual basis in calendar week 24 of each year to maintain an up-to-date data bank (although **Network Operators** may delay the submission of data (other than that to be submitted pursuant to PC.3.2(c) and PC.3.2(d)) until calendar week 28). In addition the structural data in **DRC Schedule 5** (Tables 5(a), 5(b), 5(d), 5(e), 5(f) and DRC Schedule 13 (Lumped system susceptance (PC.A.2.3) only) provided by **Network Operators** by calendar week 28 shall be updated by calendar week 50 of each year (again which may be delayed as above until week 2 of the following calendar year). Where from the date of one annual (or in the case of Schedule 5 or Schedule 13 the calendar week 50) submission to another there is no change in the data (or in some of the data) to be submitted, instead of re-submitting the data, a **User** may submit a written statement that there has been no change from the data (or some of the data) submitted the previous time; and
  - (iv) provided by **Network Operators** in connection with **Embedded Development** (PC.4.4 refers).
- (b) Where there is any change (or anticipated change) in **Committed Project Planning Data** or a significant change in **Connected Planning Data** in the category of **Forecast Data** or any change (or anticipated change) in **Connected Planning Data** in the categories of **Registered Data** or **Estimated Registered Data** supplied to **The Company** under the **PC**, notwithstanding that the change may subsequently be notified to **The Company** under the **PC** as part of the routine annual update of data (or that the change may be a **Modification** under the **CUSC**), the **User** shall, subject to PC.A.3.2.3 and PC.A.3.2.4, notify **The Company** in writing without delay.
- (c) The notification of the change will be in the form required under this **PC** in relation to the supply of that data and will also contain the following information:
- (i) the time and date at which the change became, or is expected to become, effective;
  - (ii) if the change is only temporary, an estimate of the time and date at which the data will revert to the previous registered form.
- (d) The routine annual update of data, referred to in (a)(iii) above, need not be submitted in respect of **Small Power Stations** or **Embedded** installations of direct current converters which do not form a **DC Converter Station** or **HVDC System** (except as provided in PC.3.2.(c)), or unless specifically requested by **The Company**, or unless otherwise specifically provided.

### PC.A.1.3 Submissions by The Company

**Network Data** release by **The Company** shall be:

- (a) with respect to the current **Financial Year**;

**Commented [RS463]:** Are Schedule 5 requirements being retained. (spreadsheets and single-line diagrams?) PC A.1.2. iii) in the legal text suggests these remain a requirement in Week 28 and Week 50 based on NETS maximum (Gpeak), but Schedule 5 is not included in the pack of spreadsheets. If not being retained, when would they be retired and would this be tied to specific CIM profiles being produced? E.g. equipment (EQ), diagram layout (DL) or otherwise. Noting CIM is being introduced for LTDS in stages by profile.

**Commented [RS464R463]:** Looks like PC 3.1.1.1 indicates applies until PSM Implementation date, currently listed in glossary as PSM Implementation Date

- (b) provided by **The Company** on a routine annual basis in calendar week 42 of each year. Where from the date of one annual submission to another there is no change in the data (or in some of the data) to be released, instead of repeating the data, **The Company** may release a written statement that there has been no change from the data (or some of the data) released the previous time.

The three parts of the Appendix

PC.A.1.4 The data requirements listed in this Appendix are subdivided into the following four parts:

(a) Standard Planning Data

This data (as listed in Part 1 of the Appendix) is first to be provided by a **User** at the time of an application for a **CUSC Contract** or in accordance with PC.4.4.3. It comprises data which is expected normally to be sufficient for **The Company** to investigate the impact on the **National Electricity Transmission System** of any **User Development** or **Embedded Development** associated with an application by the **User** for a **CUSC Contract**. **Users** should note that the term **Standard Planning Data** also includes the information referred to in PC.4.4.1.(a) and PC.4.4.3.(a). In the case of **OTSUA**, this data is first to be provided by a **User** in accordance with the time line in Appendix F.

(b) Detailed Planning Data

This data (as listed in Part 2 of the Appendix) includes both **DPD I** and **DPD II** and is to be provided in accordance with PC.4.4.2 and PC.4.4.4. It comprises additional, more detailed, data not normally expected to be required by **The Company** to investigate the impact on the **National Electricity Transmission System** of any **User Development** associated with an application by the **User** for a **CUSC Contract** or **Embedded Development Agreement**. **Users** and **Network Operators** in respect of **Embedded Developments** should note that the term **Detailed Planning Data** also includes **Operation Diagrams** and **Site Common Drawings** produced in accordance with the **CC** and **ECC**.

The **User** may, however, be required by **The Company** to provide the **Detailed Planning Data** in advance of the normal timescale before **The Company** can make an offer for a **CUSC Contract**, as explained in PC.4.5.

(c) Network Data

The data requirements for **The Company** in this Appendix are in Part 3.

(d) Offshore Transmission System (OTSUW) Data

**Generators** who are undertaking **OTSUW** are required to submit data in accordance with Appendix A as summarised in Schedule 18 of the **Data Registration Code**.

Forecast Data, Registered Data and Estimated Registered Data

PC.A.1.5 As explained in PC.5.4 and PC.5.5, **Planning Data** is divided into:

- (i) those items of **Standard Planning Data** and **Detailed Planning Data** known as **Forecast Data**; and
- (ii) those items of **Standard Planning Data** and **Detailed Planning Data** known as **Registered Data**; and
- (iii) those items of **Standard Planning Data** and **Detailed Planning Data** known as **Estimated Registered Data**.

PC.A.1.6 The following paragraphs in this Appendix relate to **Forecast Data**:

3.2.2(b), (h), (i) and (j)

4.2.1

4.3.1

4.3.2

4.3.3

4.3.4

4.3.5

4.5

4.7.1

5.2.1

5.2.2

5.6.1

PC.A.1.7 The following paragraphs in this Appendix relate to **Registered Data** and **Estimated Registered Data**:

2.2.1

2.2.4

2.2.5

2.2.6

2.3.1

2.4.1

2.4.2

3.2.2(a), (c), (d), (e), (f), (g), (i)(part) and (j)

3.4.1

3.4.2

4.2.3

4.5(a)(i), (a)(iii), (b)(i) and (b)(iii)

4.6

5.3.2

5.4

5.4.2

5.4.3

5.5

5.6.3

6.2

6.3

PC.A.1.8 The data supplied under PC.A.3.3.1, although in the nature of **Registered Data**, is only supplied either upon application for a **CUSC Contract**, or in accordance with PC.4.4.3, and therefore does not fall to be **Registered Data**, but is **Estimated Registered Data**.

PC.A.1.9 **Forecast Data** must contain the **User's** best forecast of the data being forecast, acting as a reasonable and prudent **User** in all the circumstances.

- PC.A.1.10 **Registered Data** must contain validated actual values, parameters or other information (as the case may be) which replace the estimated values, parameters or other information (as the case may be) which were given in relation to those data items when they were **Preliminary Project Planning Data** and **Committed Project Planning Data**, or in the case of changes, which replace earlier actual values, parameters or other information (as the case may be). Until amended pursuant to the Grid Code, these actual values, parameters or other information (as the case may be) will be the basis upon which the **National Electricity Transmission System** is planned, designed, built and operated in accordance with, amongst other things, the **Transmission Licences**, the **STC** and the Grid Code, and on which **The Company** therefore relies. In following the processes set out in the **BC**, **The Company** will use the data which has been supplied to it under the **BC** and the data supplied under **OC2** in relation to **Gensets**, but the provision of such data will not alter the data supplied by **Users** under the **PC**, which may only be amended as provided in the **PC**.
- PC.A.1.11 **Estimated Registered Data** must contain the **User's** best estimate of the values, parameters or other information (as the case may be), acting as a reasonable and prudent **User** in all the circumstances.
- PC.A.1.12 Certain data does not need to be supplied in relation to **Embedded Power Stations** or **Embedded DC Converter Stations** or **Embedded HVDC Systems** where these are connected at a voltage level below the voltage level directly connected to the **National Electricity Transmission System** except in connection with a **CUSC Contract**, or unless specifically requested by **The Company**.
- PC.A.1.13 In the case of **OTSUA**, Schedule 18 of the **Data Registration Code** shall be construed in such a manner as to achieve the intent of such provisions by reference to the **OTSUA** and the **Interface Point** and all **Connection Points**.

## PART 1 - STANDARD PLANNING DATA

### PC.A.2 USER'S SYSTEM (AND OTSUA) DATA

#### PC.A.2.1 Introduction

PC.A.2.1.1 Each **User**, whether connected directly via an existing **Connection Point** to the **National Electricity Transmission System**, or seeking such a direct connection, or providing terms for connection of an **Offshore Transmission System** to its **User System** to **The Company**, shall provide **The Company** with data on its **User System** (and any **OTSUA**) which relates to the **Connection Site** (and in the case of **OTSUA**, the **Interface Point**) and/or which may have a system effect on the performance of the **National Electricity Transmission System**. Such data, current and forecast, is specified in PC.A.2.2 to PC.A.2.5. In addition each **Generator** in respect of its **Embedded Large Power Stations** and its **Embedded Medium Power Stations** subject to a **Bilateral Agreement** and each **Network Operator** in respect of **Embedded Medium Power Stations** within its **System** not subject to a **Bilateral Agreement** connected to the **Subtransmission System**, shall provide **The Company** with fault infeed data as specified in PC.A.2.5.5 and each **DC Converter** owner with **Embedded DC Converter Stations** subject to a **Bilateral Agreement** and **Embedded HVDC System Owner** subject to a **Bilateral Agreement**, or **Network Operator** in the case of **Embedded DC Converter Stations** not subject to a **Bilateral Agreement** or **Embedded HVDC Systems** not subject to a **Bilateral Agreement**, connected to the **Subtransmission System** shall provide **The Company** with fault infeed data as specified in PC.A.2.5.6.

PC.A.2.1.2 Each **User** must reflect the system effect at the **Connection Site(s)** of any third party **Embedded** within its **User System** whether existing or proposed.

PC.A.2.1.3 Although not itemised here, each **User** with an existing or proposed **Embedded Small Power Station, Embedded Medium Power Station, Embedded DC Converter Station or HVDC System** with a **Registered Capacity** of less than 100MW or an **Embedded** installation of direct current converters which does not form a **DC Converter Station** or **HVDC System** in its **User System** may, at **The Company's** reasonable discretion, be required to provide additional details relating to the **User's System** between the **Connection Site** and the existing or proposed **Embedded Small Power Station, Embedded Medium Power Station, Embedded DC Converter Station, Embedded HVDC System** or **Embedded** installation of direct current converters which does not form a **DC Converter Station** or **Embedded** installation which does not form an **HVDC System**.

PC.A.2.1.4 At **The Company's** reasonable request, additional data on the **User's System** (or **OTSUA**) will need to be supplied. Some of the possible reasons for such a request, and the data required, are given in PC.A.6.2, PC.A.6.4, PC.A.6.5 and PC.A.6.6.

#### PC.A.2.2 User's System (and OTSUA) Layout

PC.A.2.2.1 Each **User** shall provide a **Single Line Diagram**, depicting both its existing and proposed arrangement(s) of load current carrying **Apparatus** relating to both existing and proposed **Connection Points** (including in the case of **OTSUA, Interface Points**).

PC.A.2.2.2 The **Single Line Diagram** (three examples are shown in Appendix B) must include all parts of the **User System** operating at **Supergrid Voltage** throughout **Great Britain** and, in Scotland and **Offshore**, also all parts of the **User System** operating at 132kV or greater, and those parts of its **Subtransmission System** at any **Transmission Site**. In the case of **OTSDUW**, the **Single Line Diagram** must also include the **OTSUA**. In addition, the **Single Line Diagram** must include all parts of the **User's Subtransmission System** (and any **OTSUA**) throughout **Great Britain** operating at a voltage greater than 50kV, and, in Scotland and **Offshore**, also all parts of the **User's Subtransmission System** (and any **OTSUA**) operating at a voltage greater than 30kV, which, under either intact network or **Planned Outage** conditions:

- (a) normally interconnects separate **Connection Points**, or busbars at a **Connection Point** which are normally run in separate sections; or

**Commented [BS465]:** This will increase the scope of SLDs significantly up to primary substation level.

- (b) connects **Embedded Large Power Stations**, or **Embedded Medium Power Stations**, or **Embedded DC Converter Stations**, or **Embedded HVDC Systems** or **Offshore Transmission Systems** connected to the **User's Subtransmission System**, to a **Connection Point** or **Interface Point**.

At the **User's** discretion, the **Single Line Diagram** can also contain additional details of the **User's Subtransmission System** (and any **OTSUA**) not already included above, and also details of the transformers connecting the **User's Subtransmission System** to a lower voltage. With **The Company's** agreement, the **Single Line Diagram** can also contain information about the **User's System** (and any **OTSUA**) at a voltage below the voltage of the **Subtransmission System**.

The **Single Line Diagram** for a **Power Park Module** (including **DC Connected Power Park Modules**) must include all parts of the System connecting generating equipment to the **Grid Entry Point** (or **User System Entry Point** if **Embedded**). As an alternative, the **User** may choose to submit a **Single Line Diagram** with the equipment between the equivalent **Power Park Unit** and the **Common Collection Busbar** reduced to an electrically equivalent network. The format for a **Single Line Diagram** for a **Power Park Module** (including **DC Connected Power Park Modules**) electrically equivalent system is shown in Appendix B.

The **Single Line Diagram** must include the points at which **Demand** data (provided under PC.A.4.3.4 and PC.A.4.3.5, or in the case of **Generators**, PC.A.5.) and fault infeed data (provided under PC.A.2.5) are supplied.

PC.A.2.2.3 The above-mentioned **Single Line Diagram** shall include:

- (a) electrical circuitry (i.e. overhead lines, identifying which circuits are on the same towers, underground cables, power transformers, reactive compensation equipment and similar equipment); and
- (b) substation names (in full or abbreviated form) with operating voltages.

In addition, for all load current carrying **Apparatus** operating at **Supergrid Voltage** throughout **Great Britain** and, in Scotland and **Offshore**, also at 132kV or greater, (and any **OTSUA**) the **Single Line Diagram** shall include:

- (a) circuit breakers
- (b) phasing arrangements.

PC.A.2.2.3.1 For the avoidance of doubt, the **Single Line Diagram** to be supplied is in addition to the **Operation Diagram** supplied pursuant to CC.7.4 or ECC.7.4.

PC.A.2.2.4 For each circuit shown on the **Single Line Diagram** provided under PC.A.2.2.1, each **User** shall provide the following details relating to that part of its **User System** and **OTSUA**:

- Circuit Parameters:
- Rated voltage (kV)
  - Operating voltage (kV)
  - Positive phase sequence reactance
  - Positive phase sequence resistance
  - Positive phase sequence susceptance
  - Zero phase sequence reactance (both self and mutual)
  - Zero phase sequence resistance (both self and mutual)
  - Zero phase sequence susceptance (both self and mutual)

**Commented [BS466]:** Phasing arrangements requirement is not clear. This is always going to be RYB in our network.

**Commented [BS467]:** Not sure what is required here



In the case of a **Single Line Diagram** for a **Power Park Module** (including **DC Connected Power Park Modules**) electrically equivalent system the data should be on a 100MVA base. Depending on the equivalent system supplied an equivalent tap changer range may need to be supplied. Similarly mutual values, rated voltage and operating voltage may be inappropriate. Additionally in the case of **OTSUA**, seasonal maximum continuous ratings and circuit lengths are to be provided in addition to the data required under PC.A.2.2.4.

PC.A.2.2.5 For each transformer shown on the **Single Line Diagram** provided under PC.A.2.2.1, each **User** (including those undertaking **OTSDUW**) shall provide the following details:

- Rated MVA
- Voltage Ratio
- Winding arrangement
- Positive sequence reactance (max, min and nominal tap)
- Positive sequence resistance (max, min and nominal tap)
- Zero sequence reactance

Formatted: English (United Kingdom)

PC.A.2.2.5.1. In addition, for all interconnecting transformers between the **User's Supergrid Voltage System** and the **User's Subtransmission System** throughout **Great Britain** and, in Scotland and **Offshore**, also for all interconnecting transformers operating at 132kV or greater between the **User's System** and the **User's Subtransmission System** (and any **OTSUA**) the **User** shall supply the following information:-

Formatted: English (United Kingdom)

- Tap changer range
- Tap change step size
- Tap changer type: on load or off circuit
- Earthing method: Direct, resistance or reactance
- Impedance (if not directly earthed )

Commented [BS468]: We currently not showing "Tap changer type: on load or off circuit "

PC.A.2.2.6 Each **User** shall supply the following information about the **User's** equipment installed at a **Transmission Site** (or in the case of **OTSUA**, all **OTSDUW Plant and Apparatus**):-

- (a) **Switchgear**. For all circuit breakers:-
  - Rated voltage (kV)
  - Operating voltage (kV)
  - Rated 3-phase rms short-circuit breaking current, (kA)
  - Rated 1-phase rms short-circuit breaking current, (kA)
  - Rated 3-phase peak short-circuit making current, (kA)
  - Rated 1-phase peak short-circuit making current, (kA)
  - Rated rms continuous current (A)
  - DC time constant applied at testing of asymmetrical breaking abilities (secs)In the case of **OTSDUW Plant and Apparatus** operating times for circuit breaker, **Protection**, trip relay and total operating time should be provided.
- (b) **Substation Infrastructure**. For the substation infrastructure (including, but not limited to, switch disconnectors, disconnectors, current transformers, line traps, busbars, through bushings, etc):-
  - Rated 3-phase rms short-circuit withstand current (kA)
  - Rated 1-phase rms short-circuit withstand current (kA).
  - Rated 3-phase short-circuit peak withstand current (kA)

Rated 1- phase short-circuit peak withstand current (kA)

Rated duration of short circuit withstand (secs)

Rated rms continuous current (A)

A single value for the entire substation may be supplied, provided it represents the most restrictive item of current carrying apparatus.

PC.A.2.2.7 In the case of **OTSUA** the following should also be provided

- (a) Automatic switching scheme schedules including diagrams and an explanation of how the **System** will operate and what plant will be affected by the schemes **Operation**.
- (b) **Intertipping** schemes both **Generation** and **Demand**. In each case a diagram of the scheme and an explanation of how the **System** will operate and what **Plant** will be affected by the schemes **Operation**.

PC.A.2.3 Lumped System Susceptance

PC.A.2.3.1 For all parts of the **User's Subtransmission System** (and any **OTSUA**) which are not included in the **Single Line Diagram** provided under PC.A.2.2.1, each **User** shall provide the equivalent lumped shunt susceptance at nominal **Frequency**.

PC.A.2.3.1.1 This should include shunt reactors connected to cables which are not normally in or out of service independent of the cable (ie. they are regarded as part of the cable).

PC.A.2.3.1.2 This should not include:

- (a) independently switched reactive compensation equipment connected to the **User's System** specified under PC.A.2.4, or;
- (b) any susceptance of the **User's System** inherent in the **Demand (Reactive Power)** data specified under PC.A.4.3.1.

PC.A.2.4 Reactive Compensation Equipment

PC.A.2.4.1 For all independently switched reactive compensation equipment (including any **OTSUA**), including that shown on the **Single Line Diagram**, not operated by **The Company** and connected to the **User's System** at 132kV and above in England and Wales and 33kV and above in Scotland and **Offshore** (including any **OTSDUW Plant and Apparatus** operating at **High Voltage**), other than **Power Factor** correction equipment associated directly with **Customers' Plant and Apparatus**, the following information is required:

- (a) type of equipment (eg. fixed or variable);
- (b) capacitive and/or inductive rating or its operating range in MVAR;
- (c) details of any automatic control logic to enable operating characteristics to be determined;
- (d) the point of connection to the **User's System** (including **OTSUA**) in terms of electrical location and **System** voltage.
- (e) In the case of **OTSDUW Plant and Apparatus** the **User** should also provide:-
  - (i) Connection node, voltage, rating, power loss, tap range and connection arrangement.
  - (ii) A mathematical representation in block diagram format to model the control of any dynamic compensation plant. The model should be suitable for RMS dynamic stability type studies where each time constant should be no less than 10ms.
  - (iii) For Static Var Compensation equipment the **User** should provide:

HV Node

LV Node

Control Node

Nominal Voltage (kV)

Target Voltage (kV)

Maximum MVA<sub>r</sub> at HV  
 Minimum MVA<sub>r</sub> at HV  
 Slope %  
 Voltage dependant Q Limit  
 Normal Running Mode  
 Positive and zero phase sequence resistance and reactance  
 Transformer winding type  
 Connection arrangements

PC.A.2.4.2 **DC Converter Station** owners, **HVDC System Owners** (and a **User** where the **OTSUA** includes an **OTSDUW DC Converter**) are also required to provide information about the reactive compensation and harmonic filtering equipment required to ensure that their **Plant** and **Apparatus** (and the **OTSUA**) complies with the criteria set out in CC.6.1.5 or ECC.6.1.5 (as applicable).

PC.A.2.5 Short Circuit Contribution to National Electricity Transmission System

PC.A.2.5.1 General

- (a) To allow **The Company** to calculate fault currents, each **User** is required to provide data, calculated in accordance with **Good Industry Practice**, as set out in the following paragraphs of PC.A.2.5.
- (b) The data should be provided for the **User's System** with all **Generating Units** (including **Synchronous Generating Units**), **Power Park Units**, **HVDC Systems** and **DC Converters Synchronised** to that **User's System** (and any **OTSUA** where appropriate). The **User** must ensure that the pre-fault network conditions reflect a credible **System** operating arrangement.
- (c) The list of data items required, in whole or part, under the following provisions, is set out in PC.A.2.5.6. Each of the relevant following provisions identifies which data items in the list are required for the situation with which that provision deals.  
  
 The fault currents in sub-paragraphs (a) and (b) of the data list in PC.A.2.5.6 should be based on an a.c. load flow that takes into account any pre-fault current flow across the **Point of Connection** (and in the case of **OTSUA**, **Interface Points** and **Connection Points**) being considered.  
  
 Measurements made under appropriate **System** conditions may be used by the **User** to obtain the relevant data.
- (d) **The Company** may at any time, in writing, specifically request for data to be provided for an alternative **System** condition, for example minimum plant, and the **User** will, insofar as such request is reasonable, provide the information as soon as reasonably practicable following the request.

PC.A.2.5.2 **Network Operators** and **Non-Embedded Customers** are required to submit data in accordance with PC.A.2.5.4. **Generators**, **DC Converter Station** owners, **HVDC System Owners** and **Network Operators**, in respect of **Embedded Medium Power Stations** not subject to a **Bilateral Agreement** and **Embedded DC Converter Stations** not subject to a **Bilateral Agreement** and **Embedded HVDC Systems** within such **Network Operator's Systems** are required to submit data in accordance with PC.A.2.5.5.

PC.A.2.5.3 Where prospective short-circuit currents on **Transmission** equipment are close to the equipment rating, and in **The Company's** reasonable opinion more accurate calculations of the prospective short circuit currents are required, then **The Company** will request additional data as outlined in PC.A.6.6 below.

PC.A.2.5.4 Data from Network Operators and Non-Embedded Customers

PC.A.2.5.4.1 Data is required to be provided at each node on the **Single Line Diagram** provided under PC.A.2.2.1 at which motor loads and/or **Embedded Small Power Stations** and/or **Embedded Medium Power Stations** and/or **Embedded** installations of direct current converters which do not form a **DC Converter Station** or **HVDC System** are connected, assuming a fault at that location, as follows:-

The data items listed under the following parts of PC.A.2.5.6:-

- (a) (i), (ii), (iii), (iv), (v) and (vi);

and the data items shall be provided in accordance with the detailed provisions of PC.A.2.5.6(c) - (f).

PC.A.2.5.4.2 **Network Operators** shall provide the following data items in respect of each **Interface Point** within their **User System**:

- (a) **Maximum Export Capacity**;  
(b) **Maximum Import Capacity**; and,  
(c) **Interface Point Target Voltage/Power Factor**

**Network Operators** shall alongside these parameters include details of any manual or automatic post fault actions to be taken by the owner / operator of the **Offshore Transmission System** connected to such **Interface Point** that are required by the **Network Operator**.

PC.A.2.5.5 Data from Generators (including Generators undertaking OTSDUW and those responsible for DC Connected Power Park Modules), DC Converter Station owners, HVDC System Owners and from Network Operators in respect of Embedded Medium Power Stations not subject to a Bilateral Agreement and Embedded DC Converter Stations not subject to a Bilateral Agreement and Embedded HVDC Systems within such Network Operator's Systems.

PC.A.2.5.5.1 For each **Generating Unit** (including **Synchronous Generating Units** forming part of a **Synchronous Power Generating Module**) with one or more associated **Unit Transformers**, the **Generator**, or the **Network Operator** in respect of **Embedded Medium Power Stations** not subject to a **Bilateral Agreement** and **Embedded DC Converter Stations** not subject to a **Bilateral Agreement** and **Embedded HVDC Systems** within such **Network Operator's System** is required to provide values for the contribution of the **Power Station Auxiliaries** (including **Auxiliary Energy Supplies**) to the fault current flowing through the **Unit Transformer(s)**.

The data items listed under the following parts of PC.A.2.5.6(a) should be provided:-

- (i), (ii) and (v);  
(iii) if the associated **Generating Unit** (including **Synchronous Generating Units** forming part of a **Synchronous Power Generating Module**) step-up transformer can supply zero phase sequence current from the **Generating Unit** side to the **National Electricity Transmission System**;  
(iv) if the value is not 1.0 p.u;

and the data items shall be provided in accordance with the detailed provisions of PC.A.2.5.6(c) - (f), and with the following parts of this PC.A.2.5.5.

PC.A.2.5.5.2 Auxiliary motor short circuit current contribution and any **Auxiliary Gas Turbine Unit** contribution through the **Unit Transformers** must be represented as a combined short circuit current contribution at the **Generating Unit's** (including **Synchronous Generating Units** forming part of a **Synchronous Power Generating Module**) terminals, assuming a fault at that location.

PC.A.2.5.5.3 If the **Power Station** or **HVDC System** or **DC Converter Station** (or **OTSDUW Plant and Apparatus** which provides a fault infeed) has separate **Station Transformers**, data should be provided for the fault current contribution from each transformer at its high voltage terminals, assuming a fault at that location, as follows:-

The data items listed under the following parts of PC.A.2.5.6

(a) (i), (ii), (iii), (iv), (v) and (vi);

and the data items shall be provided in accordance with the detailed provisions of PC.A.2.5.6(b) - (f).

PC.A.2.5.5.4 Data for the fault infeeds through both **Unit Transformers** and **Station Transformers** shall be provided for the normal running arrangement when the maximum number of **Generating Units** (including **Synchronous Generating Units** forming part of a **Synchronous Power Generating Module**) are **Synchronised** to the **System** or when all the **DC Converters** at a **DC Converter Station** or **HVDC Converters** within an **HVDC System** are transferring **Rated MW** in either direction. Where there is an alternative running arrangement (or transfer in the case of a **DC Converter Station** or **HVDC System**) which can give a higher fault infeed through the **Station Transformers**, then a separate data submission representing this condition shall be made.

PC.A.2.5.5.5 Unless the normal operating arrangement within the **Power Station** is to have the **Station** and **Unit Boards** interconnected within the **Power Station**, no account should be taken of the interconnection between the **Station Board** and the **Unit Board**.

PC.A.2.5.5.6 Auxiliary motor short circuit current contribution and any auxiliary **DC Converter Station** contribution or **HVDC System** contribution through the **Station Transformers** must be represented as a combined short circuit current contribution through the **Station Transformers**.

PC.A.2.5.5.7 Where a **Manufacturer's Data & Performance Report** exists in respect of the model of the **Power Park Unit**, the **User** may opt to reference the **Manufacturer's Data & Performance Report** as an alternative to the provision of data in accordance with this PC.A.2.5.5.7. For the avoidance of doubt, all other data provision pursuant to the Grid Code shall still be provided including a Single Line Diagram and those data pertaining thereto.

For each **Power Park Module** (including **DC Connected Power Park Modules**) and each type of **Power Park Unit** (eg. a Doubly Fed Induction Generator) (and any **OTSDUW Plant and Apparatus** which provides a fault infeed), including any **Auxiliaries**, positive, negative and zero sequence root mean square current values are to be provided of the contribution to the short circuit current flowing at:

- (i) the **Power Park Unit** terminals, or the **Common Collection Busbar** if an equivalent **Single Line Diagram** and associated data as described in PC.A.2.2.2 is provided, and
- (ii) the **Grid Entry Point** (and in case of **OTSUA, Transmission Interface Point**), or **User System Entry Point** if **Embedded**

for the following solid faults at the **Grid Entry Point** (and in case of **OTSUA, Interface Point**), or **User System Entry Point** if **Embedded**:

- (i) a symmetrical three phase short circuit
- (ii) a single phase to earth short circuit
- (iii) a phase to phase short circuit
- (iv) a two phase to earth short circuit

For a **Power Park Module** (including **DC Connected Power Park Modules**) in which one or more of the **Power Park Units** utilise a protective control such as a crowbar circuit, the data should indicate whether the protective control will act in each of the above cases and the effects of its action shall be included in the data. For any case in which the protective control will act, the data for the fault shall also be submitted for the limiting case in which the protective circuit will not act, which may involve the application of a non-solid fault, and the positive, negative and zero sequence retained voltages at;

- (i) the **Power Park Unit** terminals, or the **Common Collection Busbar** if an equivalent **Single Line Diagram** and associated data is provided and
  - (ii) the **Grid Entry Point**, or **User System Entry Point if Embedded**
- in this limiting case shall be provided.

For each fault for which data is submitted, the data items listed under the following parts of PC.A.2.5.6(a) shall be provided:-

- (iv), (vii), (viii), (ix), (x);

In addition, if an equivalent **Single Line Diagram** has been provided the data items listed under the following parts of PC.A.2.5.6(a) shall be provided:-

- (xi), (xii), (xiii);

In addition, for a **Power Park Module** (including **DC Connected Power Park Modules**) in which one or more of the **Power Park Units** utilise a protective control such as a crowbar circuit:-

the data items listed under the following parts of PC.A.2.5.6(a) shall be provided:-

- (xiv), (xv);

All of the above data items shall be provided in accordance with the detailed provisions of PC.A.2.5.6(c), (d), (f).

Should actual data in respect of fault infeeds be unavailable at the time of the application for a **CUSS Contract** or **Embedded Development Agreement**, a limited subset of the data, representing the maximum fault infeed that may result from all of the plant types being considered, shall be submitted. This data will, as a minimum, represent the root mean square of the positive, negative and zero sequence components of the fault current for both single phase and three phase solid faults at the **Grid Entry Point** (or **User System Entry Point if Embedded**) at the time of fault application and 50ms following fault application. Actual data in respect of fault infeeds shall be submitted to **The Company** as soon as it is available, in line with PC.A.1.2

PC.A.2.5.6

Data Items

- (a) The following is the list of data utilised in this part of the **PC**. It also contains rules on the data which generally apply:-
  - (i) Root mean square of the symmetrical three-phase short circuit current infeed at the instant of fault, ( $I_1''$ );
  - (ii) Root mean square of the symmetrical three-phase short circuit current after the subtransient fault current contribution has substantially decayed, ( $I_1'$ );
  - (iii) the zero sequence source resistance and reactance values of the **User's System** as seen from the node on the **Single Line Diagram** provided under PC.A.2.2.1 (or **Power Generating Module** or **Station Transformer** high voltage terminals or **Generating Unit** terminals or **DC Converter** terminals or **HVDC System** terminals, as appropriate) consistent with the infeed described in PC.A.2.5.1.(b);
  - (iv) root mean square of the pre-fault voltage at which the maximum fault currents were calculated;
  - (v) the positive sequence X/R ratio at the instant of fault;
  - (vi) the negative sequence resistance and reactance values of the **User's System** seen from the node on the **Single Line Diagram** provided under PC.A.2.2.1 (or **Power Generating Module** or **Station Transformer** high voltage terminals, or **Generating Unit** terminals or **DC Converter** terminals or **HVDC System** terminals as appropriate) if substantially different from the values of positive sequence resistance and reactance which would be derived from the data provided above;

- (vii) A continuous trace and a table showing the root mean square of the positive, negative and zero sequence components of the short circuit current between zero and 140ms at 10ms intervals;
  - (viii) The **Active Power** (or **Interface Point Capacity** being exported pre-fault by the **OTSDUW Plant and Apparatus**) being generated pre-fault by the **Power Park Module** (including **DC Connected Power Park Modules**) and by each type of **Power Park Unit**;
  - (ix) The reactive compensation shown explicitly on the **Single Line Diagram** that is switched in;
  - (x) The **Power Factor** of the **Power Park Module** (including **DC Connected Power Park Modules**) and of each **Power Park Unit** type;
  - (xi) The positive sequence X/R ratio of the equivalent at the **Common Collection Busbar** or **Interface Point** in the case of **OTSUA**;
  - (xii) The minimum zero sequence impedance of the equivalent seen from the **Common Collection Busbar** or **Interface Point** in the case of **OTSUA**;
  - (xiii) The number of **Power Park Units** represented in the equivalent **Power Park Unit**;
  - (xiv) The additional rotor resistance and reactance (if any) that is applied to the **Power Park Unit** under a fault condition;
  - (xv) A continuous trace and a table showing the root mean square of the positive, negative and zero sequence components of the retained voltage at the fault point and **Power Park Unit** terminals, or the **Common Collection Busbar** if an equivalent **Single Line Diagram** and associated data as described in PC.A.2.2.2 is provided or **Interface Point** in the case of **OTSUA**, representing the limiting case, which may involve the application of a non-solid fault, required to not cause operation of the protective control;
- (b) In considering this data, unless the **User** notifies **The Company** accordingly at the time of data submission, **The Company** will assume that the time constant of decay of the subtransient fault current corresponding to the change from  $I_1''$  to  $I_1'$ , ( $T''$ ) is not significantly different from 40ms. If that assumption is not correct in relation to an item of data, the **User** must inform **The Company** at the time of submission of the data.
  - (c) The value for the X/R ratio must reflect the rate of decay of the d.c. component that may be present in the fault current and hence that of the sources of the initial fault current. All shunt elements and loads must therefore be deleted from any system model before the X/R ratio is calculated.
  - (d) In producing the data, the **User** may use "time step analysis" or "fixed-point-in-time analysis" with different impedances.
  - (e) If a fixed-point-in-time analysis with different impedances method is used, then in relation to the data submitted under (a) (i) above, the data will be required for "time zero" to give  $I_1''$ . The figure of 120ms is consistent with a decay time constant  $T''$  of 40ms, and if that figure is different, then the figure of 120ms must be changed accordingly.
  - (f) Where a "time step analysis" is carried out, the X/R ratio may be calculated directly from the rate of decay of the d.c. component. The X/R ratio is not that given by the phase angle of the fault current if this is based on a system calculation with shunt loads, but from the Thévenin equivalent of the system impedance at the instant of fault with all non-source shunts removed.

- PC.A.3 POWER GENERATING MODULE, GENERATING UNIT, HVDC SYSTEM AND DC CONVERTER DATA
- PC.A.3.1 Introduction  
Directly Connected
- PC.A.3.1.1 Each **Generator, HVDC System Owner** and **DC Converter Station** owner (and a **User** where the **OTSUA** includes an **OTSDUW DC Converter**) with an existing, or proposed, **Power Station** or **DC Converter Station** or **HVDC System** directly connected, or to be directly connected, to the **National Electricity Transmission System** (or in the case of **OTSUA**, the **Interface Point**), shall provide **The Company** with data relating to that **Power Station** or **DC Converter Station** or **HVDC System**, both current and forecast, as specified in PC.A.3.2 to PC.A.3.4.
- Embedded
- PC.A.3.1.2 (a) Each **Generator, HVDC System Owner** and **DC Converter Station** owner in respect of its existing, and/or proposed, **Embedded Large Power Stations** and/or **Embedded HVDC Systems** and/or **Embedded DC Converter Stations** and/or its **Embedded Medium Power Stations** subject to a **Bilateral Agreement** and each **Network Operator** in respect of its **Embedded Medium Power Stations** not subject to a **Bilateral Agreement** and/or **Embedded DC Converter Stations** not subject to a **Bilateral Agreement** and/or **Embedded HVDC Systems** not subject to a **Bilateral Agreement** within such **Network Operator's System** in each case connected to the **Subtransmission System**, shall provide **The Company** with data relating to that **Power Station** or **DC Converter Station** or **HVC System**, both current and forecast, as specified in PC.A.3.2 to PC.A.3.4.
- (b) No data need be supplied in relation to any **Small Power Station** or any **Medium Power Station** or installations of direct current converters which do not form a **DC Converter Station** or **HVDC System**, connected at a voltage level below the voltage level of the **Subtransmission System** except:-
- (i) in connection with an application for, or under, a **CUSC Contract**, or
- (ii) unless specifically requested by **The Company** under PC.A.3.1.4.
- PC.A.3.1.3 (a) Each **Network Operator** shall provide **The Company** with the data specified in PC.A.3.2.2(c)(i) and (ii) and PC.A.3.2.2(i).
- (b) **Network Operators** need not submit planning data in respect of an **Embedded Small Power Station** unless required to do so under PC.A.1.2(b) or unless specifically requested under PC.A.3.1.4 below, in which case they will supply such data.
- PC.A.3.1.4 (a) PC.A.4.2.4(b) and PC.A.4.3.2(a) explain that the forecast **Demand** submitted by each **Network Operator** must be net of the output of all **Small Power Stations** and **Medium Power Stations** and **Customer Generating Plant** and all installations of direct current converters which do not form a **DC Converter Station** or **HVDC System**, **Embedded** within that **Network Operator's System**. The **Network Operator** must inform **The Company** of:
- (i) the number of such **Embedded Power Stations** and such **Embedded** installations of direct current converters (including the number of **Generating Units** or **Power Park Modules** (including **DC Connected Power Park Modules**) or **DC Converters** or **HVDC Systems**) together with their summated capacity; and
- (ii) beginning from the 2015 Week 24 data submission, for each **Embedded Small Power Station** of registered capacity (as defined in the **Distribution Code**) of 1MW or more:
1. A reference which is unique to each **Network Operator**;
  2. The production type as follows:
    - a) In the case of an **Embedded Small Power Station** first connected on or after 1 January 2015, the production type must be selected from the list



below:

- Biomass;
- Fossil brown coal/lignite;
- Fossil coal-derived gas;
- Fossil gas;
- Fossil hard coal;
- Fossil oil;
- Fossil oil shale;
- Fossil peat;
- Geothermal;
- Hydro pumped storage;
- Hydro run-of-river and poundage;
- Hydro water reservoir;
- Marine;
- Nuclear;
- Other renewable;
- Solar;
- Waste;
- Wind offshore;
- Wind onshore; or
- Other;

together with a statement as to whether the generation forms part of a CHP scheme;

(iii) beginning from the 2019 Week 24 data submission, for **Embedded Power Stations** with **Registered Capacity** of less than 1MW, their best estimate of the aggregated capacity of all such **Embedded Power Stations** per production type as defined in the list in PC.A.3.1.4 (a)(ii)(2)(a).

b) In the case of an **Embedded Small Power Station** first connected to the **Users' System** before 1 January 2015, as an alternative to the production type, the technology type(s) used, selected from the list set out at paragraph 2.23 in Version 2 of the Regulatory Instructions and Guidance relating to the distributed generation incentive, innovation funding incentive and registered power zones, reference 83/07, published by Ofgem in April 2007;

c) In the case of an **Embedded Small Power Station** comprising **Electricity Storage Modules** or **Electricity Storage Units** first connected to the **User's System** on or after May 20 2020, the storage type must be selected from the list below:

- Chemical
  - Ammonia
  - Hydrogen
  - Synthetic Fuels
  - Drop-in Fuels
  - Methanol
  - Synthetic Natural Gas

- Electrical
  - Supercapacitors
  - Superconducting Magnetic ES (SMES)
- Mechanical
  - Adiabatic Compressed Air
  - Diabatic Compressed Air
  - Liquid Air Energy Storage
  - Pumped Hydro
  - Flywheels
- Thermal
  - Latent Heat Storage
  - Thermochemical Storage
  - Sensible Heat Storage
- Electrochemical
  - Classic Batteries
    - Lead Acid
    - Lithium Polymer (Li-Polymer)
    - Metal Air
    - Nickle Cadmium (Ni-Cd)
    - Sodium Nickle Chloride (Na-NiCl<sub>2</sub>)
    - Lithium Ion (Li-ion)
    - Sodium Ion (Na-ion)
    - Lithium Sulphur (Li-S)
    - Sodium Sulphur(Na-S)
    - Nickle –Metal Hydride (Ni-MH)
  - Flow Batteries
    - Vanadium Red-Oxide
    - Zinc – Iron (Zn –Fe)
    - Zinc – Bromine (Zn –Br)
  - Other

Formatted: Portuguese (Brazil)

together with a statement as to whether the storage forms part of a CHP scheme. Where this information is not held by the **Network Operator** it should provide its best view of the type of storage technology.

3. The registered capacity (as defined in the **Distribution Code**) in MW;
  4. The lowest voltage level node that is specified on the most up-to-date **Single Line Diagram** to which it connects or where it will export most of its power;
  5. Where it generates electricity from wind or PV, the geographical location using either latitude or longitude or grid reference coordinates of the primary or higher voltage substation to which it connects;
  6. The reactive power and voltage control mode, including the voltage set-point and reactive range, where it operates in voltage control mode, or the target **Power Factor**, where it operates in **Power Factor** mode;
  7. Details of the types of loss of mains **Protection** in place and their relay settings which in the case of **Embedded Small Power Stations** first connected to the **Users' System** before 1 January 2015 shall be provided on a reasonable endeavours basis.
- (b) On receipt of this data, the **Network Operator** or **Generator** (if the data relates to **Power Stations** referred to in PC.A.3.1.2) may be further required, at **The Company's** reasonable discretion, to provide details of **Embedded Small Power Stations** and **Embedded Medium Power Stations** and **Customer Generating Plant** and **Embedded** installations of direct current converters which do not form a **DC Converter Station** or **HVDC System**, both current and forecast, as specified in PC.A.3.2 to PC.A.3.4. Such requirement would arise where **The Company** reasonably considers that the collective effect of a number of such **Embedded Power Stations** and **Customer Generating Plants** and **Embedded** installations of direct current converters may have a significant system effect on the **National Electricity Transmission System**.

### Busbar Arrangements

PC.A.3.1.5 Where **Generating Units**, which term includes **CCGT Units** and **Synchronous Generating Units** within a **Synchronous Power Generating Module** and **Power Park Modules** (including **DC Connected Power Park Modules**), and **DC Converters**, and **HVDC Systems** are connected to the **National Electricity Transmission System** via a busbar arrangement which is or is expected to be operated in separate sections, the section of busbar to which each **Generating Unit** (including **Synchronous Generating Units** within a **Synchronous Power Generating Module**), **DC Converter**, **HVDC System** or **Power Park Module** (including **DC Connected Power Park Modules**) is connected is to be identified in the submission.

### PC.A.3.2 Output Data

#### PC.A.3.2.1 (a) **Large Power Stations and Gensets**

Data items PC.A.3.2.2 (a), (b), (c), (d), (e), (f) and (h) are required with respect to each **Large Power Station** and each **Generating Unit** (including **Synchronous Generating Units** within a **Synchronous Power Generating Module**) and **Power Park Module** (including **DC Connected Power Park Modules**) of each **Large Power Station** and for each **Genset** (although (a) is not required for **CCGT Units** and (b), (d) and (e) are not normally required for **CCGT Units** and (a), (b), (c), (d), (e), (f) and (h) are not normally required for **Power Park Units**).

#### (b) **Embedded Small Power Stations and Embedded Medium Power Stations**

Data item PC.A.3.2.2 (a) is required with respect to each **Embedded Small Power Station** and **Embedded Medium Power Station** and each **Generating Unit** (including **Synchronous Generating Units** within a **Synchronous Power Generating Module**) and **Power Park Module** (including **DC Connected Power Park Modules**) of each **Embedded Small Power Station** and **Embedded Medium Power Station** (although (a) is not required for **CCGT Units** or **Power Park Units**). In addition, data item PC.A.3.2.2(c)(ii) is required with respect to each **Embedded Medium Power Station**.

#### (c) **CCGT Units/Modules**

- (i) Data item PC.A.3.2.2 (g) is required with respect to each **CCGT Unit**;
- (ii) data item PC.A.3.2.2 (a) is required with respect to each **CCGT Module**; and
- (iii) data items PC.A.3.2.2 (b), (c), (d) and (e) are required with respect to each **CCGT Module** unless **The Company** informs the relevant **User** in advance of the submission that it needs the data items with respect to each **CCGT Unit** for particular studies, in which case it must be supplied on a **CCGT Unit** basis.

Where any definition utilised or referred to in relation to any of the data items does not reflect **CCGT Units**, such definition shall be deemed to relate to **CCGT Units** for the purposes of these data items. Any **Schedule** in the **DRC** which refers to these data items shall be interpreted to incorporate the **CCGT Unit** basis where appropriate;

#### (d) **Cascade Hydro Schemes**

Data item PC.A.3.2.2(i) is required with respect to each **Cascade Hydro Scheme**.

#### (e) **Power Park Units/Modules**

Data items PC.A.3.2.2 (k) is required with respect to each **Power Park Module** (including **DC Connected Power Park Modules**).

#### (f) **DC Converters and HVDC Systems**

Data items PC.A.3.2.2 (a), (b), (c), (d) (e) (f) (h) and (i) are required with respect of each **HVDC System**, each **DC Converter Station** and each **DC Converter** in each **DC Converter Station**. For installations of direct current converters which do not form a **DC Converter Station** only data item PC.A.3.2.2.(a) is required.

PC.A.3.2.2 Items (a), (b), (d), (e), (f), (g), (h), (i), (j) and (k) are to be supplied by each **Generator, DC Converter Station owner, HVDC System Owner or Network Operator** (as the case may be) in accordance with PC.A.3.1.1, PC.A.3.1.2, PC.A.3.1.3 and PC.A.3.1.4. Items (a), and (f)(iv) are to be supplied (as applicable) by a **User** in the case of **OTSUA** which includes an **OTSDUW DC Converter**. Item (c) is to be supplied by each **Network Operator** in all cases:-

- (a) **Registered Capacity (MW), Maximum Capacity** (in the case of **Power Generating Modules** in addition to **Registered Capacity** on a **Power Station** basis) or **Interface Point Capacity** in the case of **OTSDUW**;
- (b) **Output Usable (MW)** on a monthly basis;
- (c) (i) **System Constrained Capacity (MW)** ie. any constraint placed on the capacity of the **Embedded Generating Unit** (including a **Synchronous Generating Unit** within a **Synchronous Power Generating Module**), **Embedded Power Park Module** (including **DC Connected Power Park Modules**) an **Offshore Transmission System** at an **Interface Point, Embedded HVDC System** or **DC Converter** at an **Embedded DC Converter Station** due to the **Network Operator's System** in which it is **Embedded**. Where **Generating Units** (which term includes **CCGT Units** and **Synchronous Generating Units** within a **Synchronous Power Generating Module**), **Power Park Modules** (including **DC Connected Power Park Modules**), **Offshore Transmission Systems** at an **Interface Point, HVDC Systems** or **DC Converters** are connected to a **Network Operator's User System** via a busbar arrangement which is or is expected to be operated in separate sections, details of busbar running arrangements and connected circuits at the substation to which the **Embedded Generating Unit** (including **Synchronous Generating Units** within an **Embedded Synchronous Power Generating Module**), **Embedded Power Park Module** (including **DC Connected Power Park Modules**), **Offshore Transmission System** at an **Interface Point, or Embedded HVDC System** or **Embedded DC Converter** is connected sufficient for **The Company** to determine where the MW generated by each **Generating Unit** (including **Synchronous Generating Units** within a **Synchronous Power Generating Module**), **Power Park Module** (including **DC Connected Power Park Modules**), **HVDC System** or **DC Converter** at that **Power Station** or **DC Converter Station** or **Offshore Transmission System** at an **Interface Point** would appear onto the **National Electricity Transmission System**;
  - (ii) any **Reactive Despatch Network Restrictions**;
- (d) **Minimum Generation (MW)**, and in the case of **Power Generating Modules** only **Minimum Stable Operating Level (MW)** and **Minimum Regulating Level**;
- (e) MW obtainable from **Generating Units** (including **Synchronous Generating Units** within a **Synchronous Power Generating Module**), **Power Park Modules** (including **DC Connected Power Park Modules**), **HVDC Systems** or **DC Converters** at a **DC Converter Station** in excess of **Registered Capacity** or **Maximum Capacity**;
- (f) **Generator Performance Chart**:
  - (i) **GB Code User(s)** in respect of **Generating Units** shall provide a **Generator Performance Chart** and **EU Code Users** in respect of **Power Generating Modules** shall provide a **Power Generating Module Performance Chart** and a **Synchronous Generating Unit Performance Chart**.
  - (ii) at the electrical point of connection to the **Offshore Transmission System** for an **Offshore Synchronous Generating Unit** and **Offshore Synchronous Power Generating Module**.
  - (iii) at the electrical point of connection to the **National Electricity Transmission System** (or **User System** if **Embedded**) for a **Non Synchronous Generating Unit** (excluding a **Power Park Unit**), **Power Park Module** (including **DC Connected Power Park Modules**), **HVDC System** and **DC Converter** at a **DC Converter Station**;
  - (iv) at the **Interface Point** for **OTSDUW Plant and Apparatus**

Where a **Reactive Despatch Network Restriction** applies, its existence and details should be highlighted on the **Generator Performance Chart**, in sufficient detail for **The Company** to determine the nature of the restriction.

- (g) a list of the **CCGT Units** within a **CCGT Module**, identifying each **CCGT Unit**, and the **CCGT Module** of which it forms part, unambiguously. In the case of a **Range CCGT Module**, details of the possible configurations should also be submitted, together:-
  - (i) (in the case of a **Range CCGT Module** connected to the **National Electricity Transmission System**) with details of the single **Grid Entry Point** (there can only be one) at which power is provided from the **Range CCGT Module**;
  - (ii) (in the case of an **Embedded Range CCGT Module**) with details of the single **User System Entry Point** (there can only be one) at which power is provided from the **Range CCGT Module**;

Provided that, nothing in this sub-paragraph (g) shall prevent the busbar at the relevant point being operated in separate sections;

- (h) expected running regime(s) at each **Power Station**, **HVDC System** or **DC Converter Station** and type of **Power Generating Module** or **Generating Unit** (as applicable), eg. **Steam Unit**, **Gas Turbine Unit**, **Combined Cycle Gas Turbine Unit**, **Power Park Module** (including **DC Connected Power Park Modules**), **Novel Units** (specify by type), etc;
- (i) a list of **Power Stations** and **Generating Units** within a **Cascade Hydro Scheme**, identifying each **Generating Unit** (including **Synchronous Generating Units** within a **Synchronous Power Generating Module**) and **Power Station** and the **Cascade Hydro Scheme** of which each form part unambiguously. In addition:
  - (i) details of the **Grid Entry Point** at which **Active Power** is provided, or if **Embedded** the **Grid Supply Point(s)** within which the **Generating Unit** (including **Synchronous Generating Units** within a **Synchronous Power Generating Module**) is connected;
  - (ii) where the **Active Power** output of a **Generating Unit** is split between more than one **Grid Supply Points** the percentage that would appear under normal and outage conditions at each **Grid Supply Point**.
- (j) The following additional items are only applicable to **DC Converters** at **DC Converter Stations** and **HVDC Systems**.
  - Registered Import Capacity (MW)**;
  - Import Usable (MW)** on a monthly basis;
  - Minimum Import Capacity (MW)**;
  - MW that may be absorbed by a **DC Converter** or **HVDC System** in excess of **Registered Import Capacity** and **Maximum HVDC Active Power Transmission Capacity** under importing conditions and the duration for which this is available;
- (k) the number and types of the **Power Park Units** within a **Power Park Module** (including **DC Connected Power Park Modules**), identifying each **Power Park Unit**, the **Power Park Module** of which it forms part and identifying the **BM Unit** of which each **Power Park Module** forms part, unambiguously. In the case of a **Power Station** directly connected to the **National Electricity Transmission System** with multiple **Power Park Modules** (including **DC Connected Power Park Modules**) where **Power Park Units** can be selected to run in different **Power Park Modules** and/or **Power Park Modules** can be selected to run in different **BM Units**, details of the possible configurations should also be submitted. In addition, for **Offshore Power Park Modules** (including **DC Connected Power Park Modules**), the number of **Offshore Power Park Strings** that are aggregated into one **Offshore Power Park Module** should also be submitted.

- (l) the number and types of the **Synchronous Generating Units** within a **Synchronous Power Generating Module**, identifying each **Synchronous Generating Unit**, the **Synchronous Power Generating Module** of which it forms part and identifying the **BM Unit** of which each **Synchronous Power Generating Module** forms part, unambiguously. In the case of a **Power Station** directly connected to the **National Electricity Transmission System** with multiple **Synchronous Power Generating Modules** where **Synchronous Generating Units** can be selected to run in different **Synchronous Power Generating Modules** and/or **Synchronous Power Generating Modules** can be selected to run in different **BM Units**, details of the possible configurations should also be submitted.

PC.A.3.2.3 Notwithstanding any other provision of this PC, the **CCGT Units** within a **CCGT Module**, details of which are required under paragraph (g) of PC.A.3.2.2, can only be amended in accordance with the following provisions:-

- (a) if the **CCGT Module** is a **Normal CCGT Module**, the **CCGT Units** within that **CCGT Module** can only be amended such that the **CCGT Module** comprises different **CCGT Units** if **The Company** gives its prior consent in writing. Notice of the wish to amend the **CCGT Units** within such a **CCGT Module** must be given at least 6 months before it is wished for the amendment to take effect;
- (b) if the **CCGT Module** is a **Range CCGT Module**, the **CCGT Units** within that **CCGT Module** and the **Grid Entry Point** at which the power is provided can only be amended as described in BC1.A1.6.4.

PC.A.3.2.4 Notwithstanding any other provision of this PC, the **Power Park Units** within a **Power Park Module** (including **DC Connected Power Park Modules**), and the **Power Park Modules** (including **DC Connected Power Park Modules**) within a **BM Unit**, details of which are required under paragraph (k) of PC.A.3.2.2, can only be amended in accordance with the following provisions:-

- (a) if the **Power Park Units** within that **Power Park Module** can only be amended such that the **Power Park Module** comprises different **Power Park Units** due to repair/replacement of individual **Power Park Units** if **The Company** gives its prior consent in writing. Notice of the wish to amend a **Power Park Unit** within such a **Power Park Module** (including **DC Connected Power Park Modules**) must be given at least 4 weeks before it is wished for the amendment to take effect;
- (b) if the **Power Park Units** within that **Power Park Module** (including **DC Connected Power Park Modules**) and/or the **Power Park Modules** (including **DC Connected Power Park Modules**) within that **BM Unit** can be selected to run in different **Power Park Modules** and/or **BM Units** as an alternative operational running arrangement the **Power Park Units** within the **Power Park Module**, the **BM Unit** of which each **Power Park Module** forms part, and the **Grid Entry Point** at which the power is provided can only be amended as described in BC1.A.1.8.4.

PC.A.3.2.5 Notwithstanding any other provision of this PC, the **Synchronous Generating Units** within a **Synchronous Power Generating Module**, and the **Synchronous Power Generating Modules** within a **BM Unit**, details of which are required under paragraph (l) of PC.A.3.2.2, can only be amended in accordance with the following provisions:-

- (a) if the **Synchronous Generating Units** within that **Synchronous Power Generating Module** can only be amended such that the **Synchronous Power Generating Module** comprises different **Synchronous Generating Units** due to repair/replacement of individual **Synchronous Generating Units** if **The Company** gives its prior consent in writing. Notice of the wish to amend a **Synchronous Generating Unit** within such a **Synchronous Power Generating Module** must be given at least 4 weeks before it is wished for the amendment to take effect;

- (b) if the **Synchronous Generating Units** within that **Synchronous Power Generating Module** and/or the **Synchronous Power Generating Modules** within that **BM Unit** can be selected to run in different **Synchronous Power Generating Modules** and/or **BM Units** as an alternative operational running arrangement the **Synchronous Generating Units** within the **Synchronous Power Generating Module**, the **BM Unit** of which each **Synchronous Power Generating Module** forms part, and the **Grid Entry Point** at which the power is provided can only be amended as described in BC1.A.1.9.4(c). The requirements of PC.A.3.2.5 need not be satisfied if **Generators** have already submitted data in respect of PC.A.3.2.3, PC.A.3.2.4 and PC.A.3.2.5 for the same **Power Generating Module**.

PC.A.3.3. Rated Parameters Data

PC.A.3.3.1 The following information is required to facilitate an early assessment, by **The Company**, of the need for more detailed studies;

- (a) for all **Generating Units** (excluding **Power Park Units**) and **Power Park Modules** (including **DC Connected Power Park Modules**):

Rated MVA

**Rated MW;**

- (b) for each **Synchronous Generating Unit** (including **Synchronous Generating Units** within a **Synchronous Power Generating Module**):

Short circuit ratio

Direct axis transient reactance;

Inertia constant (for whole machine), MWsecs/MVA;

- (c) for each **Synchronous Generating Unit** step-up transformer (including the step up transformer of a **Synchronous Generating Unit** within a **Synchronous Power Generating Module**):

Rated MVA

Positive sequence reactance (at max, min and nominal tap);

- (d) for each **DC Converter** at a **DC Converter Station**, **HVDC System**, **DC Converter** connecting a **Power Park Module** (including a **DC Connected Power Park Module**) and **Transmission DC Converter** (forming part of an **OTSUA**).

**DC Converter** or **HVDC Converter** type (e.g. current/voltage sourced)

**Rated MW** per pole for import and export

Number of poles and pole arrangement

Rated DC voltage/pole (kV)

Return path arrangement

Remote AC connection arrangement (excluding **OTSDUW DC Converters**)

**Maximum HVDC Active Power Transmission Capacity**

**Minimum Active Power Transmission Capacity**

- (e) for each type of **Power Park Unit** in a **Power Park Module** not connected to the **Total System** by a **DC Converter** or **HVDC System**:

Rated MVA

**Rated MW**

Rated terminal voltage

Inertia constant, (MWsec/MVA)

Additionally, for **Power Park Units** that are squirrel-cage or doubly-fed induction generators driven by wind turbines:

Stator reactance.

Magnetising reactance.

Rotor resistance (at rated running)

Rotor reactance (at rated running)

The generator rotor speed range (minimum and maximum speeds in RPM) (for doubly-fed induction generators only)

Converter MVA rating (for doubly-fed induction generators only)

For a **Power Park Unit** consisting of a synchronous machine in combination with a back-to-back **DC Converter** or **HVDC Converter**, or for a **Power Park Unit** not driven by a wind turbine, the data to be supplied shall be agreed with **The Company** in accordance with PC.A.7.

This information should only be given in the data supplied in accordance with PC.4.4 and PC.4.5.

PC.A.3.4 General Generating Unit, Power Park Module (including DC Connected Power Park Modules), Power Generating Module, HVDC System and DC Converter Data

PC.A.3.4.1 The point of connection to the **National Electricity Transmission System** or the **Total System**, if other than to the **National Electricity Transmission System**, in terms of geographical and electrical location and system voltage is also required.

PC.A.3.4.2 (a) Type of **Generating Unit** (ie **Synchronous Power Generating Unit** within a **Power Generating Module, Synchronous Generating Unit, Non-Synchronous Generating Unit, DC Converter, Power Park Module** (including **DC Connected Power Park Modules**) or **HVDC System**).

(b) In the case of a **Synchronous Generating Unit** (including **Synchronous Generating Units** within a **Synchronous Power Generating Module**) details of the **Exciter** category, for example whether it is a rotating **Exciter** or a static **Exciter** or in the case of a **Non-Synchronous Generating Unit** the voltage control system.

(c) Whether a **Power System Stabiliser** is fitted.

PC.A.3.4.3 Each **Generator** shall supply **The Company** with the production type(s) used as the primary source of power in respect of each **Generating Unit** (including **Synchronous Generating Units** within a **Synchronous Power Generating Module**), selected from the list set out below:

- Biomass
- Fossil brown coal/lignite
- Fossil coal-derived gas
- Fossil gas
- Fossil hard coal
- Fossil oil
- Fossil oil shale
- Fossil peat
- Geothermal
- Hydro pumped storage
- Hydro run-of-river and poundage
- Hydro water reservoir
- Marine



- Nuclear
- Other renewable
- Solar
- Waste
- Wind offshore
- Wind onshore
- Other

PC.A.3.4.4 In the case of an **Electricity Storage Module** or **Electricity Storage Unit**, each **Generator** shall supply **The Company** with the production type(s) used as the primary **Electricity Storage** source (including **Synchronous Electricity Storage Units** within a **Synchronous Electricity Storage Module**), selected from the list set out below:

- Chemical
  - Ammonia
  - Hydrogen
  - Synthetic Fuels
  - Drop-in Fuels
  - Methanol
  - Synthetic Natural Gas
- Electrical
  - Supercapacitors
  - Superconducting Magnetic ES (SMES)
- Mechanical
  - Adiabatic Compressed Air
  - Diabatic Compressed Air
  - Liquid Air Energy Storage
  - Pumped Hydro
  - Flywheels
- Thermal
  - Latent Heat Storage
  - Thermochemical Storage
  - Sensible Heat Storage
- Electrochemical
  - Classic Batteries
    - Lead Acid
    - Lithium Polymer (Li-Polymer)
    - Metal Air
    - Nickle Cadmium (Ni-Cd)
    - Sodium Nickle Chloride (Na-NiCl<sub>2</sub>)
    - Lithium Ion (Li-ion)
    - Sodium Ion (Na-ion)
    - Lithium Sulphur (Li-S)
    - Sodium Sulphur(Na-S)
    - Nickle –Metal Hydride (Ni-MH)
  - Flow Batteries
    - Vanadium Red-Oxide
    - Zinc – Iron (Zn –Fe)
    - Zinc – Bromine (Zn –Br)
  - Other

Formatted: Portuguese (Brazil)

PC.A.4 DEMAND AND ACTIVE ENERGY DATA

PC.A.4.1 Introduction

- PC.A.4.1.1 Each **User** directly connected to the **National Electricity Transmission System** with **Demand** shall provide **The Company** with the **Demand** data, historic, current and forecast, as specified in PC.A.4.2 and PC.A.4.3. Paragraphs PC.A.4.1.2 and PC.A.4.1.3 apply equally to **Active Energy** requirements as to **Demand** unless the context otherwise requires.
- PC.A.4.1.2 Data will need to be supplied by:
- (a) each **Network Operator**, in relation to **Demand** and **Active Energy** requirements on its **User System**;
  - (b) each **Non-Embedded Customer, Pumped Storage Generators** (with respect to Pumping **Demand**) and **Generators** in relation to **Electricity Storage Modules** in relation to their **Demand** and **Active Energy** requirements.
  - (c) each **DC Converter Station** owner or **HVDC System Owner** in relation to **Demand** and **Active Energy** transferred (imported) to its **DC Converter Station** or **HVDC System**.
  - (d) each **OTSDUW DC Converter** in relation to the Demand at each **Interface Point** and **Connection Point**.
- Demand** of **Power Stations** directly connected to the **National Electricity Transmission System** is to be supplied by the **Generator** under PC.A.5.2.
- PC.A.4.1.3 References in this **PC** to data being supplied on a half hourly basis refer to it being supplied for each period of 30 minutes ending on the hour or half-hour in each hour.
- PC.A.4.1.4 **Access Periods** and **Access Groups**
- PC.A.4.1.4.1 Each **Connection Point** must belong to one, and only one, **Access Group**.
- PC.A.4.1.4.2 Each **Transmission Interface Circuit** must have an **Access Period**.
- PC.A.4.1.4.3 The **Access Period** shall
- (a) normally be a minimum of 8 continuous weeks and can occur in any one of three maintenance years during the period from calendar week 13 to calendar week 43 (inclusive) in each year; or,
  - (b) exceptionally and provided that agreement is reached between **The Company** and the relevant **User(s)**, such agreement to be sought in accordance with PC.7, the **Access Period** may be of a period not less than 4 continuous weeks and can occur in any one of three maintenance years during the period from calendar week 10 to calendar week 43 (inclusive) in each year.
- PC.A.4.1.4.4 **The Company** shall submit in writing no later than calendar week 6 in each year:
- (a) the calendar weeks defining the proposed start and finish of each **Access Period** for each **Transmission Interface Circuit**; and
  - (b) the **Connection Points** in each **Access Group**.
- The submission by **The Company** under PC.A.4.1.4.4 (a) above shall commence in 2010 and shall then continue each year thereafter. The submission by **The Company** under PC.A.4.1.4.4 (b) shall commence in 2009 and then continue each year thereafter.
- PC.A.4.1.4.5 It is permitted for **Access Periods** to overlap in the same **Access Group** and in the same maintenance year. However, where possible **Access Periods** will be sought by **The Company** that do not overlap with any other **Access Period** within that **Access Group** for each maintenance year. Where it is not possible to avoid overlapping **Access Periods**, **The Company** will indicate to **Users** by calendar week 6 its initial view of which **Transmission Interface Circuits** will need to be considered out of service concurrently for the purpose of assessing compliance to **Licence Standards**. The obligation on **The Company** to indicate which **Transmission Interface Circuits** will need to be considered out of service concurrently for the purpose of assessing compliance to **Licence Standards** shall commence in 2010 and shall continue each year thereafter.

PC.A.4.1.4.6 Following the submission(s) by **The Company** by week 6 in each year and where required by either party, both **The Company** and the relevant **User(s)** shall use their reasonable endeavours to agree the appropriate **Access Group(s)** and **Access Period** for each **Transmission Interface Circuit** prior to week 17 in each year. The requirement on **The Company** and the relevant **User(s)** to agree, shall commence in respect of **Access Groups** only in 2010. This paragraph PC.A.4.1.4.6 shall apply in its entirety in 2011 and shall then continue each year thereafter.

PC.A.4.1.4.7 In exceptional circumstances, and with the agreement of all parties concerned, where a **Connection Point** is specified for the purpose of the **Planning Code** as electrically independent **Subtransmission Systems**, then data submissions can be on the basis of two (or more) individual **Connection Points**.

PC.A.4.2 User's User System Demand (Active Power) and Active Energy Data

PC.A.4.2.1 Forecast daily **Demand (Active Power)** profiles, as specified in (a), (b) and (c) below, in respect of each of the **User's User Systems** (each summated over all **Grid Supply Points** in each **User System**) are required for:

- (a) peak day on each of the **User's User Systems** (as determined by the **User**) giving the numerical value of the maximum **Demand (Active Power)** that in the **Users'** opinion could reasonably be imposed on the **National Electricity Transmission System**;
- (b) day of peak **National Electricity Transmission System Demand (Active Power)** as notified by **The Company** pursuant to PC.A.4.2.2;
- (c) day of minimum **National Electricity Transmission System Demand (Active Power)** as notified by **The Company** pursuant to PC.A.4.2.2.

In addition, the total **Demand (Active Power)** in respect of the time of peak **National Electricity Transmission System Demand** in the preceding **Financial Year** in respect of each of the **User's User Systems** (each summated over all **Grid Supply Points** in each **User System**) both outturn and weather corrected shall be supplied.

PC.A.4.2.2 No later than calendar week 17 each year, **The Company** shall notify each **Network Operator** and **Non-Embedded Customer** in writing of the following, for the current **Financial Year** and for each of the following seven **Financial Years**, which will, until replaced by the following year's notification, be regarded as the relevant specified days and times under PC.A.4.2.1:

- (a) the date and time of the annual peak of the **National Electricity Transmission System Demand**;
- (b) the date and time of the annual minimum of the **National Electricity Transmission System Demand**;
- (c) the relevant **Access Period** for each **Transmission Interface Circuit**; and,
- (d) concurrent **Access Periods** of two or more **Transmission Interface Circuits** (if any) that are situated in the same **Access Group**.

The submissions by **The Company** made under PC.A.4.2.1 (c) and PC.A.4.2.1 (d) above shall commence in 2010 and shall then continue in respect of each year thereafter.

PC.A.4.2.3 The total **Active Energy** used on each of the **Network Operators'** or **Non-Embedded Customers' User Systems** (each summated over all **Grid Supply Points** in each **User System**) in the preceding **Financial Year**, both outturn and weather corrected, together with a prediction for the current financial year, is required. Each **Active Energy** submission shall be subdivided into the following categories of **Customer** tariff:

- LV1
- LV2
- LV3
- HV
- EHV

Traction

Lighting

In addition, the total **User System** losses and the **Active Energy** provided by **Embedded Small Power Stations** and **Embedded Medium Power Stations** shall be supplied.

PC.A.4.2.4 All forecast **Demand (Active Power)** and **Active Energy** specified in PC.A.4.2.1 and PC.A.4.2.3 shall:

- (a) in the case of PC.A.4.2.1(a), (b) and (c), be such that the profiles comprise average **Active Power** levels in 'MW' for each time marked half hour throughout the day;
- (b) in the case of PC.A.4.2.1(a), (b) and (c), be that remaining after any deductions reasonably considered appropriate by the **User** to take account of the output profile of all **Embedded Small Power Stations** and **Embedded Medium Power Stations** and **Customer Generating Plant** and imports across **Embedded External Interconnections** including imports across **Embedded** installations of direct current converters which do not form a **DC Converter Station** or **HVDC System** and **Embedded DC Converter Stations** and **Embedded HVDC Systems** with a **Registered Capacity** or **HVDC Active Power Transmission Capacity** of less than 100MW;
- (c) be based upon **Annual ACS Conditions** for times that occur during week 44 through to week 12 (inclusive) and based on **Average Conditions** for weeks 13 to 43 (inclusive).

PC.A.4.3 Connection Point Demand (Active and Reactive Power)

PC.A.4.3.1 Forecast **Demand (Active Power)** and **Power Factor** (values of the **Power Factor** at maximum and minimum continuous excitation may be given instead where more than 95% of the total **Demand** at a **Connection Point** is taken by synchronous motors) to be met at each **Connection Point** within each **Access Group** is required for:

- (a) the time of the maximum **Demand (Active Power)** at the **Connection Point** (as determined by the **User**) that in the **User's** opinion could reasonably be imposed on the **National Electricity Transmission System**;
- (b) the time of peak **National Electricity Transmission System Demand** as provided by **The Company** under PC.A.4.2.2;
- (c) the time of minimum **National Electricity Transmission System Demand** as provided by **The Company** under PC.A.4.2.2;
- (d) the time of the maximum **Demand (Apparent Power)** at the **Connection Point** (as determined by the **User**) during the **Access Period** of each **Transmission Interface Circuit**;
- (e) at a time specified by either **The Company** or a **User** insofar as such a request is reasonable.

Instead of such forecast **Demand** to be met at each **Connection Point** within each **Access Group** the **User** may (subject to PC.A.4.3.4) submit such **Demand** at each node on the **Single Line Diagram**.

In addition, the **Demand** in respect of each of the time periods referred to in PC.A.4.3.1 (a) to (e) in the preceding **Financial Year** in respect of each **Connection Point** within each **Access Group** both outturn and weather corrected shall be supplied. The "weather correction" shall normalise outturn figures to **Annual ACS Conditions** for times that occur during calendar week 44 through to calendar week 12 (inclusive) or **Average Conditions** for the period calendar weeks 13 to calendar week 43 (inclusive) and shall be performed by the relevant **User** on a best endeavours basis.

The submission by a **User** pursuant to PC.A.4.3.1 (d) shall commence in 2011 and shall then continue each year thereafter.

PC.A.4.3.2 All forecast **Demand** specified in PC.A.4.3.1 shall:

- (a) be that remaining after any deductions reasonably considered appropriate by the **User** to take account of the output of all **Embedded Small Power Stations** and **Embedded Medium Power Stations** and **Customer Generating Plant** and imports across **Embedded External Interconnections**, including **Embedded** installations of direct current converters which do not form a **DC Converter Station, HVDC System** and **Embedded DC Converter Stations** and **Embedded HVDC Systems** and such deductions should be separately stated;
- (b) include any **User's System** series reactive losses but exclude any reactive compensation equipment specified in PC.A.2.4 and exclude any network susceptance specified in PC.A.2.3;
- (c) be based upon **Annual ACS Conditions** for times that occur during calendar week 44 through to calendar week 12 (inclusive) and based on **Average Conditions** for calendar weeks 13 to calendar week 43 (inclusive), both corrections being made on a best endeavours basis;
- (d) reflect the **User's** opinion of what could reasonably be imposed on the **National Electricity Transmission System**.

PC.A.4.3.3 The date and time of the forecast maximum **Demand (Apparent Power)** at the **Connection Point** as specified in PC.A.4.3.1 (a) and (d) is required.

PC.A.4.3.4 Each **Single Line Diagram** provided under PC.A.2.2.2 shall include the **Demand (Active Power)** and **Power Factor** (values of the **Power Factor** at maximum and minimum continuous excitation may be given instead where more than 95% of the **Demand** is taken by synchronous motors) at the time of the peak **National Electricity Transmission System Demand** (as provided under PC.A.4.2.2) at each node on the **Single Line Diagram**. These **Demands** shall be consistent with those provided under PC.A.4.3.1(b) above for the relevant year.

PC.A.4.3.5 The **Single Line Diagram** must represent the **User's User System** layout under the period specified in PC.A.4.3.1(b) (at the time of peak **National Electricity Transmission System Demand**). Should the **User's User System** layout during the other times specified in PC.A.4.3.1 be planned to be materially different from the **Single Line Diagram** submitted to **The Company** pursuant to PC.A.2.2.1 the **User** shall in respect of such other times submit:

- (i) an alternative **Single Line Diagram** that accurately reflects the revised layout and in such case shall also include appropriate associated data representing the relevant changes, or;
- (ii) submit an accurate and unambiguous description of the changes to the **Single Line Diagram** previously submitted for the time of peak **National Electricity Transmission System Demand**.

Where a **User** does not submit any changes, **The Company** will assume that the **Single Line Diagram** (and associated circuit and node data) provided at the time of peak **National Electricity Transmission System Demand** will be valid for all other times. In respect of such other times, where the **User** does not submit such nodal demands at the times defined in PC.A.4.3.1(a), (c), (d) and (e), the nodal demands will be pro-rata, to be consistent with the submitted **Connection Point Demands**.

PC.A.4.4 **The Company** will assemble and derive in a reasonable manner, the forecast information supplied to it under PC.A.4.2.1, PC.A.4.3.1, PC.A.4.3.4 and PC.A.4.3.5 above into a cohesive forecast and will use this in preparing **Forecast Demand** information in the **Seven Year Statement** and for use in **The Company's Operational Planning**. If any **User** believes that the cohesive forecast **Demand** information in the **Seven Year Statement** does not reflect its assumptions on **Demand**, it should contact **The Company** to explain its concerns and may require **The Company**, on reasonable request, to discuss these forecasts. In the absence of such expressions, **The Company** will assume that **Users** concur with **The Company's** cohesive forecast.

PC.A.4.5 Post Fault User System Layout

PC.A.4.5.1 Where for the purposes of **The Company** assessing against the Licence Standards an **Access Group**, the **User** reasonably considers it appropriate that revised post fault **User System** layouts should be taken into account by **The Company**, the following information is required to be submitted by the **User**:

- (i) the specified **Connection Point** assessment period (PC.A.4.3.1,(a)-(e)) that is being evaluated;
- (ii) an accurate and unambiguous description of the **Transmission Interface Circuits** considered to be switched out due to a fault;
- (iii) appropriate revised **Single Line Diagrams** and/or associated revised nodal **Demand** and circuit data detailing the revised **User System(s)** conditions;
- (iv) where the **User's** planned post fault action consists of more than one component, each component must be explicitly identified using the **Single Line Diagram** and associated nodal **Demand** and circuit data;
- (v) the arrangements for undertaking actions (eg the time taken, automatic or manual and any other appropriate information);.

The **User** must not submit any action that it does not have the capability or the intention to implement during the assessment period specified (subject to there being no further unplanned outages on the **User's User System**).

PC.A.4.6 Control of Demand or Reduction of Pumping Load Offered as Reserve

Magnitude of <b>Demand</b> or pumping load or <b>Electricity Storage Module</b> charging load which is tripped	MW
<b>System Frequency</b> at which tripping is initiated	Hz
Time duration of <b>System Frequency</b> below trip setting for tripping to be initiated	S
Time delay from trip initiation to tripping	S

PC.A.4.7 General Demand Data

PC.A.4.7.1 The following information is infrequently required and should be supplied (wherever possible) when requested by **The Company**:

- (a) details of any individual loads (including (as applicable) the load behaviour of an **Electricity Storage Module** when operating in a mode analogous to demand) which have characteristics significantly different from the typical range of Domestic, Commercial, **Electricity Storage** or Industrial loads supplied;
- (b) the sensitivity of the **Demand (Active and Reactive Power)** to variations in voltage and **Frequency** on the **National Electricity Transmission System** at the time of the peak **Demand (Active Power)**. The sensitivity factors quoted for the **Demand (Reactive Power)** should relate to that given under PC.A.4.3.1 and, therefore, include any **User's System** series reactive losses but exclude any reactive compensation equipment specified in PC.A.2.4 and exclude any network susceptance specified in PC.A.2.3;
- (c) details of any traction loads, e.g. connection phase pairs and continuous load variation with time;
- (d) the average and maximum phase unbalance, in magnitude and phase angle, which the **User** would expect its **Demand** to impose on the **National Electricity Transmission System**;
- (e) the maximum harmonic content which the **User** would expect its **Demand** to impose on the **National Electricity Transmission System**;
- (f) details of all loads which may cause **Demand** fluctuations greater than those permitted under **Engineering Recommendation P28 Issue 2, Stage 1** at a **Point of Common Coupling** including the **Flicker Severity Short Term** and the **Flicker Severity Long Term**.

(g) In the case of **Electricity Storage Modules**, details of the **Maximum Capacity, Maximum Import Power, Registered Import Capability**, charge time, discharge time and operating periods.

## PART 2 - DETAILED PLANNING DATA

PC.A.5 POWER GENERATING MODULE, GENERATING UNIT, POWER PARK MODULE (INCLUDING DC CONNECTED POWER PARK MODULES), DC CONVERTER, HVDC EQUIPMENT AND OTSDUW PLANT AND APPARATUS DATA

PC.A.5.1 Introduction

### Directly Connected

PC.A.5.1.1 Each **Generator** (including those undertaking **OTSDUW**), with existing or proposed **Power Stations** directly connected, or to be directly connected, to the **National Electricity Transmission System**, shall provide **The Company** with data relating to that **Plant** and **Apparatus**, both current and forecast, as specified in PC.A.5.2, PC.A.5.3, PC.A.5.4 and PC.A.5.7 as applicable.

Each **DC Converter Station** owner or **HVDC System Owner**, with existing or proposed **DC Converter Stations** or **HVDC Systems** (including **Generators** undertaking **OTSDUW** which includes an **OTSDUW DC Converter**) directly connected, or to be directly connected, to the **National Electricity Transmission System**, shall provide **The Company** with data relating to that **Plant** and **Apparatus**, both current and forecast, as specified in PC.A.5.2 and PC.A.5.4.

**GB Generators, DC Converter Station** owners, **EU Generators** and **HVDC System Owners** shall ensure that the models supplied in respect of their **Plant** and **Apparatus** provide a true and accurate behaviour of the plant as built as required under PC.A.5.3.2(c), PC.A.5.4.2(a) and PC.A.5.4.3 and verified through the **Compliance Processes (CP)** or **European Compliance Processes (ECP)** as applicable.

### Embedded

PC.A.5.1.2 Each **Generator**, in respect of its existing, or proposed, **Embedded Large Power Stations** and its **Embedded Medium Power Stations** subject to a **Bilateral Agreement** and each **Network Operator** in respect of **Embedded Medium Power Stations** not subject to a **Bilateral Agreement** within its **System** shall provide **The Company** with data relating to each of those **Large Power Stations** and **Medium Power Stations**, both current and forecast, as specified in PC.A.5.2, PC.A.5.3, PC.A.5.4 and PC.A.5.7 as applicable.

Each **DC Converter Station** owner or **HVDC System Owner**, or **Network Operator** in the case of an **Embedded DC Converter Station** or **Embedded HVDC System** not subject to a **Bilateral Agreement** within its **System** with existing or proposed **HVDC Systems** or **DC Converter Stations** shall provide **The Company** with data relating to each of those **HVDC Systems** or **DC Converter Stations**, both current and forecast, as specified in PC.A.5.2 and PC.A.5.4.

However, no data need be supplied in relation to those **Embedded Medium Power Stations** or **Embedded DC Converter Stations** or **Embedded HVDC Systems** if they are connected at a voltage level below the voltage level of the **Subtransmission System** except in connection with an application for, or under a, **CUSC Contract** or unless specifically requested by **The Company** under PC.A.5.1.4.

**GB Generators, DC Converter Station** owners, **EU Generators** and **HVDC System Owners** shall ensure that the models supplied in respect of their **Plant** and **Apparatus** provide a true and accurate behaviour of the plant as built as required under PC.A.5.3.2(c), PC.A.5.4.2(a) and PC.A.5.4.3 and verified through the **Compliance Processes (CP)** or **European Compliance Processes (ECP)** as applicable

PC.A.5.1.3 Each **Network Operator** need not submit **Planning Data** in respect of **Embedded Small Power Stations** unless required to do so under PC.A.1.2(b), PC.A.3.1.4 or unless specifically requested under PC.A.5.1.4 below, in which case they will supply such data.



PC.A.5.1.4 PC.A.4.2.4(b) and PC.A.4.3.2(a) explained that the forecast **Demand** submitted by each **Network Operator** must be net of the output of all **Medium Power Stations** and **Small Power Stations** and **Customer Generating Plant Embedded** within that **User's System**. In such cases, the **Network Operator** must provide **The Company** with the relevant information specified under PC.A.3.1.4 . On receipt of this data further details may be required at **The Company's** discretion as follows:

- (i) in the case of details required from the **Network Operator** for **Embedded Medium Power Stations** not subject to a **Bilateral Agreement** and **Embedded DC Converter Stations** not subject to a **Bilateral Agreement** and **Embedded HVDC Systems** not subject to a **Bilateral Agreement** and **Embedded Small Power Stations** and **Embedded DC Converters** and **Embedded HVDC Systems** in each case within such **Network Operator's System** and **Customer Generating Plant**; and
- (ii) in the case of details required from the **Generator** of **Embedded Large Power Stations** and **Embedded Medium Power Stations** subject to a **Bilateral Agreement**; and
- (iii) in the case of details required from the **DC Converter Station** owner of an **Embedded DC Converter** or **DC Converter Station** or **HVDC System Owner** of an **Embedded HVDC System Owner** subject to a **Bilateral Agreement**.

both current and forecast, as specified in PC.A.5.2 and PC.A.5.3. Such requirement would arise when **The Company** reasonably considers that the collective effect of a number of such **Embedded Small Power Stations**, **Embedded Medium Power Stations**, **Embedded DC Converter Stations**, **Embedded HVDC Systems**, **DC Converters** and **Customer Generating Plants** may have a significant system effect on the **National Electricity Transmission System**.

PC.A.5.1.5 DPD I and DPD II

The **Detailed Planning Data** described in this Part 2 of the Appendix comprises both **DPD I** and **DPD II**. The required data is listed and collated in the **Data Registration Code**. The **Users** need to refer to the **DRC** to establish whether data referred to here is **DPD I** or **DPD II**.

PC.A.5.2 Demand

PC.A.5.2.1 For each **Generating Unit** (including **Synchronous Generating Units** within a **Synchronous Power Generating Module**) which has an associated **Unit Transformer**, the value of the **Demand** supplied through this **Unit Transformer** when the **Generating Unit** is at **Rated MW** output is to be provided.

PC.A.5.2.2 Where the **Power Station** or **DC Converter Station** or **HVDC System** has associated **Demand** additional to the unit-supplied **Demand** of PC.A.5.2.1 which is supplied from either the **National Electricity Transmission System** or the **Generator's User System** the **Generator**, **DC Converter Station** owner, **HVDC System Owner** or the **Network Operator** (in the case of **Embedded Medium Power Stations** not subject to a **Bilateral Agreement** within its **System**), as the case may be, shall supply forecasts for each **Power Station** or **DC Converter Station** or **HVDC System** of:

- (a) the maximum **Demand** that, in the **User's** opinion, could reasonably be imposed on the **National Electricity Transmission System** or the **Generator's User System** as appropriate;
- (b) the **Demand** at the time of the peak **National Electricity Transmission System Demand**
- (c) the **Demand** at the time of minimum **National Electricity Transmission System Demand**.

PC.A.5.2.3 No later than calendar week 17 each year **The Company** shall notify each **Generator** in respect of its **Large Power Stations** and its **Medium Power Stations** and each **DC Converter** owner in respect of its **DC Converter Station** and each **HVDC System Owner** in respect of its **HVDC System** subject to a **Bilateral Agreement** and each **Network Operator** in respect of each **Embedded Medium Power Station** not subject to a **Bilateral Agreement** and each **Embedded DC Converter Station** or **Embedded HVDC System** not subject to a **Bilateral Agreement** within such **Network Operator's System** in writing of the following, for the current **Financial Year** and for each of the following seven **Financial Years**, which will be regarded as the relevant specified days and times under PC.A.5.2.2:

- (a) the date and time of the annual peak of the **National Electricity Transmission System Demand at Annual ACS Conditions**;
- (b) the date and time of the annual minimum of the **National Electricity Transmission System Demand at Average Conditions**.

PC.A.5.2.4 At its discretion, **The Company** may also request further details of the **Demand** as specified in PC.A.4.6

PC.A.5.2.5 In the case of **OTSDUW Plant and Apparatus** the following data shall be supplied:

- (a) The maximum **Demand** that could occur at the **Interface Point** and each **Connection Point** (in MW and MVA);
- (b) **Demand** at specified time of annual peak half hour of **National Electricity Transmission System Demand at Annual ACS Conditions** (in MW and MVA); and
- (c) **Demand** at specified time of annual minimum half-hour of **National Electricity Transmission System Demand** (in MW and MVA).

For the avoidance of doubt, **Demand** data associated with **Generators** undertaking **OTSDUW** which utilise an **OTSDUW DC Converter** should supply data under PC.A.4.

PC.A.5.3 Synchronous Power Generating Modules, Synchronous Generating Unit and Associated Control System Data

PC.A.5.3.1 The data submitted below are not intended to constrain any **Ancillary Services Agreement**

PC.A.5.3.2 The following **Synchronous Generating Unit** (including **Synchronous Generating Units** within a **Synchronous Power Generating Module**) and **Power Station** data should be supplied:

(a) **Synchronous Generating Unit** Parameters

Rated terminal volts (kV)

Maximum terminal voltage set point (kV)

Terminal voltage set point step resolution – if not continuous (kV)

\* Rated MVA

\* **Rated MW**

\* Minimum Generation MW

\* Short circuit ratio

Direct axis synchronous reactance

\* Direct axis transient reactance

Direct axis sub-transient reactance

Direct axis short-circuit transient time constant

Direct axis short-circuit sub-transient time constant

Quadrature axis synchronous reactance

Quadrature axis sub-transient reactance

Quadrature axis short-circuit sub-transient time constant.

Stator time constant

Stator leakage reactance

Armature winding direct-current resistance.

Note: The above data item relating to armature winding direct-current resistance need only be supplied with respect to **Generating Units** commissioned after 1st March 1996 and in cases where, for whatever reason, the **Generator** or the **Network Operator**, as the case may be is aware of the value of the relevant parameter.

- \* Turbogenerator inertia constant (MWsec/MVA)

Rated field current (amps) at **Rated MW** and MVA<sub>r</sub> output and at rated terminal voltage.

Field current (amps) open circuit saturation curve for **Generating Unit** terminal voltages ranging from 50% to 120% of rated value in 10% steps as derived from appropriate manufacturers test certificates.

- (b) Parameters for **Generating Unit** Step-up Transformers

- \* Rated MVA

Voltage ratio

- \* Positive sequence reactance (at max, min, & nominal tap)

Positive sequence resistance (at max, min, & nominal tap)

Zero phase sequence reactance

Tap changer range

Tap changer step size

Tap changer type: on load or off circuit

- (c) Excitation Control System parameters

Note: The data items requested under Option 1 below may continue to be provided in relation to **Generating Units** connected to the **System** at 09 January 1995 (in this paragraph, the "relevant date") or the new data items set out under Option 2 may be provided. **Generators** or **Network Operators**, as the case may be, must supply the data as set out under Option 2 (and not those under Option 1) for **Generating Unit** excitation control systems commissioned after the relevant date, those **Generating Unit** excitation control systems recommissioned for any reason such as refurbishment after the relevant date and **Generating Unit** excitation control systems where, as a result of testing or other process, the **Generator** or **Network Operator**, as the case may be, is aware of the data items listed under Option 2 in relation to that **Generating Unit**.

For any excitation control systems associated with a **Generating Unit** or **Synchronous Power Generating Module** with a **Completion Date** after 1 September 2022 and any **Generating Unit** or **Synchronous Power Generating Module** excitation control systems subject to a control system change or **Modification** after 1 September 2022, the **Generator** should supply the control system model in accordance with PC.A.9. For the avoidance of doubt, excitation control system models as detailed in PC.A.9 maybe submitted for any **Generating Unit** regardless of **Completion Date** as an alternative to block diagrams detailed below. The control system model of the **Excitation System** shall include but not limited to, the **PSS** if fitted, **Over-excitation Limiter**, **Under-excitation Limiter** and should have been verified as far as reasonably practicable by simulation studies as representing the expected behaviour of the control system. Additionally the data items listed under Option 2 below are also required.

#### Option 1

DC gain of Excitation Loop

Rated field voltage

Maximum field voltage

Minimum field voltage

Maximum rate of change of field voltage (rising)

Maximum rate of change of field voltage (falling)

Details of Excitation Loop described in block diagram form showing transfer functions of individual elements.

Dynamic characteristics of **Over-excitation Limiter**

Dynamic characteristics of **Under-excitation Limiter**

#### Option 2

**Excitation System Nominal Response**

**Rated Field Voltage**

**No-Load Field Voltage**

**Excitation System On-Load Positive Ceiling Voltage**

**Excitation System No-Load Positive Ceiling Voltage**

**Excitation System No-Load Negative Ceiling Voltage**

Stator Current Limiter (applicable only to **Synchronous Power Generating Modules**)

Details of **Excitation System** (including **PSS** if fitted) described in block diagram form showing transfer functions of individual elements.

Details of **Over-excitation Limiter** described in block diagram form showing transfer functions of individual elements.

Details of **Under-excitation Limiter** described in block diagram form showing transfer functions of individual elements.

The block diagrams submitted after 1 January 2009 in respect of the **Excitation System** (including the **Over-excitation Limiter** and the **Under-excitation Limiter**) for **Generating Units** with a **Completion date** after 1 January 2009 or subject to a **Modification** to the **Excitation System** after 1 January 2009, should have been verified as far as reasonably practicable by simulation studies as representing the expected behaviour of the system.

#### (d) Governor Parameters

Incremental **Droop** values (in %) are required for each **Generating Unit** at six MW loading points (MLP1 to MLP6) as detailed in PC.A.5.5.1 (this data item needs only be provided for **Large Power Stations**).

Note: The data items requested under Option 1 below may continue to be provided by **Generators** in relation to **Generating Units** on the **System** at 09 January 1995 (in this paragraph, the "relevant date") or they may provide the new data items set out under Option 2. **Generators** must supply the data as set out under Option 2 (and not those under Option 1) for **Generating Unit** governor control systems commissioned after the relevant date, those **Generating Unit** governor control systems recommissioned for any reason such as refurbishment after the relevant date and **Generating Unit** governor control systems where, as a result of testing or other process, the **Generator** is aware of the data items listed under Option 2 in relation to that **Generating Unit**. **EU Generators** are also required to submit the data as set out in option 2. Additional data required from **EU Generators** which own or operate **Type C** or **Type D Power Generating Modules** are marked in brackets with an asterisk (eg (\*)). For the avoidance of doubt, items marked as (\*) need not be supplied by **GB Generators**.

For any governor control systems associated with a **Generating Unit** or **Synchronous Power Generating Module** with a **Completion Date** after 1 September 2022 and any **Generating Unit** or **Synchronous Power Generating Module** governor control systems subject to a control system change or **Modification** after 1 September 2022, the **Generator** should supply the control system model in accordance with PC.A.9. For the avoidance of doubt, governor control system models as detailed in PC.A.9 maybe submitted for any **Generating Unit** regardless of **Completion Date** as an alternative to governor block diagrams. The control system model shall include but not limited to, the governor and prime mover dynamics such as steam flow, boiler, water flow which could impact on representation of the requirements required by the Grid Code. Additional the data items listed under Option 2 are also required.

#### Option 1

(i) Governor Parameters (for Reheat **Steam Units**)

- HP governor average gain MW/Hz
- Speeder motor setting range
- HP governor valve time constant
- HP governor valve opening limits
- HP governor valve rate limits
- Reheater time constant (**Active Energy** stored in reheater)

- IP governor average gain MW/Hz
- IP governor setting range
- IP governor valve time constant
- IP governor valve opening limits
- IP governor valve rate limits

Details of acceleration sensitive elements in HP & IP governor loop.

A governor block diagram showing transfer functions of individual elements.

(ii) Governor Parameters (for Non-Reheat **Steam Units** and **Gas Turbine Units**)

- Governor average gain
- Speeder motor setting range
- Time constant of steam or fuel governor valve
- Governor valve opening limits

Governor valve rate limits  
Time constant of turbine  
Governor block diagram

The following data items need only be supplied for **Large Power Stations**:

(iii) Boiler & Steam Turbine Data

Boiler Time Constant (Stored **Active Energy**) s

HP turbine response ratio:

proportion of **Primary Response** arising from HP turbine %

HP turbine response ratio:

proportion of High Frequency Response arising from HP turbine %

[End of Option 1]

Option 2

(i) Governor and associated prime mover Parameters - All **Generating Units** (including **Synchronous Generating Units** within a **Synchronous Power Generating Module**)

Governor Block Diagram showing transfer function of individual elements including acceleration sensitive elements.

Governor Time Constant (in seconds)

**Speeder Motor Setting Range (%)**

Average Gain (MW/Hz)

**Governor Deadband** need only be provided for **Large Power Stations** owned and operated by **GB Generators** (and both **Frequency Response Deadband** and **Frequency Response Insensitivity** should be supplied in respect of **Type C** and **D Power Generating Modules** within **Large Power Stations** and **Medium Power Stations** excluding **Embedded Medium Power Stations** not subject to a **Bilateral Agreement\***) owned and operated by **EU Code Generators**.

- Maximum Setting ±Hz

- Normal Setting ±Hz

- Minimum Setting ±Hz

Where the **Generating Unit** governor does not have a selectable **Governor Deadband** (or **Frequency Response Deadband** and **Frequency Response Insensitivity**)\* facility as specified above, then the actual value of the **Governor Deadband** or (**Frequency Response Deadband** and **Frequency Response Insensitivity**)\* need only be provided.

The block diagrams submitted after 1 January 2009 in respect of the governor system for **Generating Units** with a **Completion date** after 1 January 2009 or subject to a **Modification** to the governor system after 1 January 2009, should have been verified as far as reasonably practicable by simulation studies as representing the expected behaviour of the system.

(ii) Governor and associated prime mover Parameters - **Steam Units**

HP Valve Time Constant (in seconds)

HP Valve Opening Limits (%)

HP Valve Opening Rate Limits (%/second)  
HP Valve Closing Rate Limits (%/second)  
HP Turbine Time Constant (in seconds)

IP Valve Time Constant (in seconds)  
IP Valve Opening Limits (%)  
IP Valve Opening Rate Limits (%/second)  
IP Valve Closing Rate Limits (%/second)  
IP Turbine Time Constant (in seconds)

LP Valve Time Constant (in seconds)  
LP Valve Opening Limits (%)  
LP Valve Opening Rate Limits (%/second)  
LP Valve Closing Rate Limits (%/second)  
LP Turbine Time Constant (in seconds)  
Reheater Time Constant (in seconds)  
Boiler Time Constant (in seconds)  
HP Power Fraction (%)  
IP Power Fraction (%)

(iii) Governor and associated prime mover Parameters - **Gas Turbine Units**

Inlet Guide Vane Time Constant (in seconds)  
Inlet Guide Vane Opening Limits (%)  
Inlet Guide Vane Opening Rate Limits (%/second)  
Inlet Guide Vane Closing Rate Limits (%/second)  
Fuel Valve Constant (in seconds)  
Fuel Valve Opening Limits (%)  
Fuel Valve Opening Rate Limits (%/second)  
Fuel Valve Closing Rate Limits (%/second)  
Waste Heat Recovery Boiler Time Constant (in seconds)

(iv) Governor and associated prime mover Parameters - Hydro Generating Units

Guide Vane Actuator Time Constant (in seconds)  
Guide Vane Opening Limits (%)  
Guide Vane Opening Rate Limits (%/second)  
Guide Vane Closing Rate Limits (%/second)  
Water Time Constant (in seconds)

(v) Governor Parameters – Synchronous Electricity Storage Units

For **Synchronous Electricity Storage Modules** which are derived from compressed air energy storage systems, the following data should be provided. For other **Synchronous Electricity Storage Modules**, data should be supplied as required by **The Company** in accordance with PC.A.7

Valve Actuator Time Constant (in seconds)  
 Valve Opening Limits (%)  
 Valve Opening Rate Limits (%/second)  
 Valve Closing Rate Limits (%/second)

[End of Option 2]

(e) Unit Control Options

The following data items need only be supplied with respect to **Large Power Stations**:

Maximum <b>Droop</b>	%
Normal <b>Droop</b>	%
Minimum <b>Droop</b>	%
Maximum <b>Governor Deadband</b> or (maximum <b>Frequency Response Deadband</b> and maximum <b>Frequency Response Insensitivity</b> *)	±Hz
Normal <b>Governor Deadband</b> or (normal <b>Frequency Response Deadband</b> and normal <b>Frequency Response Insensitivity</b> *)	±Hz
Minimum <b>Governor Deadband</b> or (minimum <b>Frequency Response Deadband</b> and minimum <b>Frequency Response Insensitivity</b> *)	±Hz
Maximum output <b>Governor Deadband</b> (or maximum output <b>Frequency Response Deadband</b> and maximum <b>Frequency Response Insensitivity</b> *)	±MW
Normal output <b>Governor Deadband</b> (or normal output <b>Frequency Response Deadband</b> and normal output <b>Frequency Response Insensitivity</b> *)	±MW
Minimum output <b>Governor Deadband</b> (or minimum output <b>Frequency Response Deadband</b> and minimum output <b>Frequency Response Insensitivity</b> *)	±MW

**Frequency** settings between which Unit Load Controller **Droop** applies:

- Maximum	Hz
- Normal	Hz
- Minimum	Hz

▲ State if sustained response is normally selected.

Formatted: Portuguese (Brazil)

(\* **GB Generators** which are not required to satisfy the requirements of the **European Connection Conditions** are not required to supply **Frequency Response Insensitivity** or **Frequency Response Deadband** data but should instead supply **Governor Deadband** data). For the avoidance of doubt, **EU Code Generators** in respect of **Type C** and **Type D Power Generating Modules** are required to supply **Frequency Response Deadband** and **Frequency Response Insensitivity** data).

(f) Plant Flexibility Performance

The following data items need only be supplied with respect to **Large Power Stations**, and should be provided with respect to each **Genset**:

- # Run-up rate to **Registered Capacity**,
- # Run-down rate from **Registered Capacity**,
- # **Synchronising Generation**,  
 Regulating range  
 Load rejection capability while still **Synchronised** and able to supply **Load**.



Data items marked with a hash (#) should be applicable to a **Genset** which has been **Shutdown** for 48 hours.

- \* Data items marked with an asterisk are already requested under partx1, PC.A.3.3.1, to facilitate an early assessment by **The Company** as to whether detailed stability studies will be required before an offer of terms for a **CUSC Contract** can be made. Such data items have been repeated here merely for completeness and need not, of course, be resubmitted unless their values, known or estimated, have changed.

(g) **Generating Unit Mechanical Parameters**

It is occasionally necessary for **The Company** to assess the interaction between the **Total System** and the mechanical components of **Generating Units**. For **Generating Units** (including **Synchronous Generating Units** within a **Synchronous Power Generating Module**) with a **Completion Date** on or after 01 April 2015,

or:

with a **Completion Date** before 01 April 2015 when requested by **The Company** in accordance with good industry practice and without undue delay.

the following data items should be supplied:

The number of turbine generator masses.

Diagram showing the Inertia and parameters for each turbine generator mass (kgm<sup>2</sup>) and Stiffness constants and parameters between each turbine generator mass for the complete drive train (Nm/rad).

Number of poles.

Relative power applied to different parts of the turbine (%).

Torsional mode frequencies (Hz).

Modal damping decrement factors for the different mechanical modes.

PC.A.5.4 **Power Park Module, Non-Synchronous Generating Unit and Associated Control System Data**

PC.A.5.4.1 The data submitted below are not intended to constrain any **Ancillary Services Agreement**

PC.A.5.4.2 The following **Power Park Unit, Power Park Module** and **Power Station** data should be supplied in the case of a **Power Park Module** not connected to the **Total System** by a **DC Converter** or **HVDC System** (and in the case of PC.A.5.4.2(f) any **OTSUA**):

Where a **Manufacturer's Data & Performance Report** exists in respect of the model of the **Power Park Unit**, the **User** may subject to **The Company's** agreement, opt to reference the **Manufacturer's Data & Performance Report** as an alternative to the provision of data in accordance with PC.A.5.4.2 except for:

- (1) the section marked thus # at sub paragraph (b); and
- (2) all of the harmonic and flicker parameters required under sub paragraph (h); and
- (3) all of the site specific model parameters relating to the voltage or frequency control systems required under sub paragraphs (d) and (e),

which must be provided by the **User** in addition to the **Manufacturer's Data & Performance Report** reference.

- (a) **Power Park Unit** model

A mathematical model of each type of **Power Park Unit** (including **Electricity Storage Units**) capable of representing its transient and dynamic behaviour under both small and large disturbance conditions. The model shall include non-linear effects and represent all equipment relevant to the dynamic performance of the **Power Park Unit** as agreed with **The Company**. The model shall be suitable for the study of balanced, root mean square, positive phase sequence time-domain behaviour, excluding the effects of electromagnetic transients, harmonic and sub-harmonic frequencies.

The model shall accurately represent the overall performance of the **Power Park Unit** over its entire operating range including that which is inherent to the **Power Park Unit** and that which is achieved by use of supplementary control systems providing either continuous or stepwise control. Model resolution should be sufficient to accurately represent **Power Park Unit** behaviour both in response to operation of **Transmission System** protection and in the context of longer-term simulations.

The overall structure of the model shall include:

- (i) any supplementary control signal modules not covered by (c), (d) and (e) below.
- (ii) any blocking, deblocking and protective trip features that are part of the **Power Park Unit** (e.g. "crowbar").
- (iii) any other information required to model the **Power Park Unit** behaviour to meet the model functional requirement described above.

The model shall be submitted in the form of a transfer function block diagram and may be accompanied by dynamic and algebraic equations.

This model shall display all the transfer functions and their parameter values, any non wind-up logic, signal limits and non-linearities.

The submitted **Power Park Unit** model and the supplementary control signal module models covered by (c), (d) and (e) below shall have been validated and this shall be confirmed by the **Generator**. The validation shall be based on comparing the submitted model simulation results against measured test results. Validation evidence shall also be submitted and this shall include the simulation and measured test results. The latter shall include appropriate short-circuit tests. In the case of an **Embedded Medium Power Station** not subject to a **Bilateral Agreement** the **Network Operator** will provide **The Company** with the validation evidence if requested by **The Company**. The validation of the supplementary control signal module models covered by (c), (d) and (e) below applies only to a **Power Park Module** with a **Completion Date** after 1 January 2009 or **Power Park Modules** within a **Power Generating Module**.

(b) **Power Park Unit** parameters

- \* Rated MVA
- \* **Rated MW**
- \* Rated terminal voltage
- \* Average site air density ( $\text{kg/m}^3$ ), maximum site air density ( $\text{kg/m}^3$ ) and minimum site air density ( $\text{kg/m}^3$ ) for the year (as applicable)

Year for which the air density is submitted (as applicable)

Number of pole pairs (as applicable)

Blade swept area ( $\text{m}^2$ ) (as applicable)

Gear box ratio (as applicable)

Mechanical drive train (as applicable)

For each **Power Park Unit**, details of the parameters of the drive train (as applicable) represented as an equivalent two mass model should be provided. This model should accurately represent the behaviour of the complete drive train for the purposes of power system analysis studies and should include the following data

items:-

Equivalent inertia constant (MWsec/MVA) of the first mass (e.g. wind turbine rotor and blades) at minimum, synchronous and rated speeds

Equivalent inertia constant (MWsec/MVA) of the second mass (e.g. generator rotor) at minimum, synchronous and rated speeds

Equivalent shaft stiffness between the two masses (Nm/electrical radian)

Additionally, for **Power Park Units** that are induction generators (e.g. squirrel cage, doubly-fed) driven by wind turbines:

- \* Stator resistance
- \* Stator reactance
- \* Magnetising reactance.
- \* Rotor resistance.(at starting)
- \* Rotor resistance.(at rated running)
- \* Rotor reactance (at starting)
- \* Rotor reactance (at rated running)

Additionally for doubly-fed induction generators only:

The generator rotor speed range (minimum and maximum speeds in RPM)

The optimum generator rotor speed versus wind speed submitted in tabular format

Power converter rating (MVA)

The rotor power coefficient ( $C_p$ ) versus tip speed ratio ( $\lambda$ ) curves for a range of blade angles (where applicable) together with the corresponding values submitted in tabular format. The tip speed ratio ( $\lambda$ ) is defined as  $\Omega R/U$  where  $\Omega$  is the angular velocity of the rotor, R is the radius of the wind turbine rotor and U is the wind speed.

The electrical power output versus generator rotor speed for a range of wind speeds over the entire operating range of the **Power Park Unit**, together with the corresponding values submitted in tabular format.

The blade angle versus wind speed curve together with the corresponding values submitted in tabular format.

The electrical power output versus wind speed over the entire operating range of the **Power Park Unit**, together with the corresponding values submitted in tabular format.

Transfer function block diagram, including parameters and description of the operation of the power electronic converter and fault ride through capability (where applicable). For any **Power Park Units** in a **Power Park Module** with a **Completion Date** after 1 September 2022 and any **Power Park Units** subject to a control system change or **Modification** after 1 September 2022 control system models in accordance with PC.A.9 should be supplied. For the avoidance of doubt, a **User** may submit control system models as detailed in PC.A.9 for any **Power Park Unit** regardless of **Power Park Module Completion Date** as an alternative to this paragraph.

For a **Power Park Unit** consisting of a synchronous machine in combination with a back to back **DC Converter** or **HVDC System**, or for a **Power Park Unit** not driven by a wind turbine, the data to be supplied shall be agreed with **The Company** in accordance with PC.A.7.

- (c) Torque / speed and blade angle control systems and parameters
- For the type of **Power Park Unit** (as applicable), details of the torque / speed controller and blade angle controller in the case of a wind turbine and power limitation functions (where applicable) described in block diagram form showing transfer functions and parameters of individual elements.
- (d) Voltage/**Reactive Power/Power Factor** control system parameters
- For the **Power Park Unit** and **Power Park Module** details of voltage/**Reactive Power/Power Factor** controller (and **PSS** if fitted) described in block diagram form showing transfer functions and parameters of individual elements.
- (e) **Frequency** control system parameters
- For the **Power Park Unit** and **Power Park Module** details of the **Frequency** controller described in block diagram form showing transfer functions and parameters of individual elements.
- (f) **Protection**
- Details of settings for the following **Protection** relays (to include): Under **Frequency**, over **Frequency**, under voltage, over voltage, rotor over current, stator over current, high wind speed shut down level.
- (g) Complete **Power Park Unit** model, parameters and controls
- (i) For any **Power Park Units** in a **Power Park Module** with a **Completion Date** after 1 September 2022 and any **Power Park Units** and/or **Power Park Module(s)** subject to a control system change or **Modification** after 1 September 2022, control system models in accordance with PC.A.9 should be supplied covering the full information required under PC.A.5.4.2 (a), (b), (c), (d), (e) and (f).
- (ii) For any **Power Park Units** in a **Power Park Module** with a **Completion Date** before 1 September 2022 as an alternative to PC.A.5.4.2 (a), (b), (c), (d), (e) and (f), is the submission of a single complete model that consists of the full information required under PC.A.5.4.2 (a), (b), (c), (d), (e) and (f) provided that all the information required under PC.A.5.4.2 (a), (b), (c), (d), (e) and (f) individually is clearly identifiable. For the avoidance of doubt, a **User** may submit control system models as detailed in PC.A.9 for any **Power Park Unit** or **Power Park Module** regardless of **Completion Date** as an alternative to this clause.
- (h) Harmonic and flicker parameters
- When connecting a **Power Park Module**, it is necessary for **The Company** to evaluate the production of flicker and harmonics on the **National Electricity Transmission System** and **User's Systems**. At **The Company's** reasonable request, the **User** (a **Network Operator** in the case of an **Embedded Power Park Module** not subject to a **Bilateral Agreement**) is required to submit the following data (as defined in IEC 61400-21 (2001)) for each **Power Park Unit**:-
- Flicker coefficient for continuous operation.
  - Flicker step factor.
  - Number of switching operations in a 10 minute window.
  - Number of switching operations in a 2 hour window.
  - Voltage change factor.
  - Current Injection at each harmonic for each **Power Park Unit** and for each **Power Park Module**.

\* Data items marked with an asterisk are already requested under part 1, PC.A.3.3.1, to facilitate an early assessment by **The Company** as to whether detailed stability studies will be required before an offer of terms for a **CUSC Contract** can be made. Such data items have been repeated here merely for completeness and need not, of course, be resubmitted unless their values, known or estimated, have changed.

PC.A.5.4.3 DC Converter and HVDC Systems

PC.A.5.4.3.1 For a **DC Converter** at a **DC Converter Station** or an **HVDC System** connected to the **Total System** by a **DC Converter** or **HVDC System** (or in the case of **OTSUA** which includes an **OTSDUW DC Converter**) the following information for each **DC Converter**, **HVDC System** and **DC Network** should be supplied:

- (a) **DC Converter** and **HVDC System** parameters
- \* **Rated MW** per pole for transfer in each direction;
  - \* **DC Converter** type (i.e. current or voltage source (including a **HVDC Converter** in an **HVDC System**));
  - \* Number of poles and pole arrangement;
  - \* Rated DC voltage/pole (kV);
  - \* Return path arrangement;
- (b) **DC Converter** and **HVDC System** transformer parameters
- Rated MVA
  - Nominal primary voltage (kV);
  - Nominal secondary (converter-side) voltage(s) (kV);
  - Winding and earthing arrangement;
  - Positive phase sequence reactance at minimum, maximum and nominal tap;
  - Positive phase sequence resistance at minimum, maximum and nominal tap;
  - Zero phase sequence reactance;
  - Tap-changer range in %;
  - number of tap-changer steps;
- (c) **DC Network** parameters
- Rated DC voltage per pole;
  - Rated DC current per pole;
  - Single line diagram of the complete **DC Network** and **HVDC System**;
  - Details of the complete **DC Network**, including resistance, inductance and capacitance of all DC cables and/or DC lines and **HVDC System**;
  - Details of any DC reactors (including DC reactor resistance), DC capacitors and/or DC-side filters that form part of the **DC Network** and/or **HVDC System**;
- (d) AC filter reactive compensation equipment parameters
- Note: The data provided pursuant to this paragraph must not include any contribution from reactive compensation plant.
- Total number of AC filter banks.

Type of equipment (e.g. fixed or variable)

Single line diagram of filter arrangement and connections;

**Reactive Power** rating for each AC filter bank, capacitor bank or operating range of each item of reactive compensation equipment, at rated voltage;

Performance chart showing **Reactive Power** capability of the **DC Converter** and **HVDC System**, as a function of MW transfer, with all filters and reactive compensation plant, belonging to the **DC Converter Station** or **HVDC System** working correctly.

Note: Details in PC.A.5.4.3.1 are required for each **DC Converter** connected to the **DC Network** and **HVDC System**, unless each is identical or where the data has already been submitted for an identical **DC Converter** or **HVDC System** at another **Connection Point**.

Note: For a **Power Park Module** and **DC Connected Power Park Module** connected to the **Grid Entry Point** or (**User System Entry Point** if **Embedded**) by a **DC Converter** or **HVDC System** the equivalent inertia and fault infeed at the **Power Park Unit** should be given.

#### DC Converter and HVDC System Control System Models

PC.A.5.4.3.2 The following data is required by **The Company** to represent **DC Converters** and associated **DC Networks** and **HVDC Systems** (and including **OTSUA** which includes an **OTSDUW DC Converter**) in dynamic power system simulations,

- (a) For any any **DC Converters** and **HVDC Systems** with a **Completion Date** before 1 September 2022 in which the AC power system is typically represented by a positive sequence equivalent, it is acceptable to represent **DC Converters** and **HVDC Systems** by simplified equations rather than to the switching device level.
  - (i) Static  $V_{DC-I_{DC}}$  (DC voltage - DC current) characteristics, for both the rectifier and inverter modes for a current source converter. Static  $V_{DC-P_{DC}}$  (DC voltage - DC power) characteristics, for both the rectifier and inverter modes for a voltage source converter. Transfer function block diagram including parameters representation of the control systems of each **DC Converter** and of the **DC Converter Station** and the **HVDC System**, for both the rectifier and inverter modes. A suitable model would feature the **DC Converter** or **HVDC Converter** firing angle as the output variable.
  - (ii) Transfer function block diagram representation including parameters of the **DC Converter** or **HVDC Converter** transformer tap changer control systems, including time delays
  - (iii) Transfer function block diagram representation including parameters of AC filter and reactive compensation equipment control systems, including any time delays.
  - (iv) Transfer function block diagram representation including parameters of any **Frequency** and/or load control systems.
  - (v) Transfer function block diagram representation including parameters of any small signal modulation controls such as power oscillation damping controls or sub-synchronous oscillation damping controls, that have not been submitted as part of the above control system data.
  - (vi) Transfer block diagram representation of the **Reactive Power** control at converter ends for a voltage source converter.

In addition and where not provided for above, **HVDC System Owners** and **Generators** in respect of **OTSDUW DC Converters** who are also **EU Code Users** shall also provide the following dynamic simulation sub-models

- (i) **HVDC Converter** unit models
- (ii) AC component models
- (iii) DC Grid models
- (iv) Voltage and power controller

- (v) Special control features if applicable (eg power oscillation damping (POD) function, subsynchronous torsional interaction (SSTI) control;
- (vi) Multi terminal control, if applicable
- (vii) **HVDC System** protection models as agreed between **The Company** and the **HVDC System Owner**

**HVDC System Owners** are also required to supply an equivalent model of the control system when adverse control interactions may result with **HVDC Converter Stations** and other connections in close proximity if requested by **The Company**. The equivalent model shall contain all necessary data for the realistic simulation of the adverse control interactions.

- (b) For any **DC Converters** and **HVDC Systems** with a **Completion Date** after 1 September 2022 and any **DC Converters** and **HVDC Systems** subject to a control system change or **Modification** after 1 September 2022, control system models in accordance with PC.A.9 should be supplied covering the full functionality required under PC.A.5.4.3.2 (a).

For the avoidance of doubt a **User** may submit control system models as detailed in PC.A.9 for any **DC Converters** and **HVDC Systems** regardless of **Completion Date** as an alternative to PC.A.5.4.3.2(a).

Plant Flexibility Performance

PC.A.5.4.3.3 The following information on plant flexibility and performance should be supplied (and also in respect of **OTSUA** which includes an **OTSDUW DC Converter**):

- (i) Nominal and maximum (emergency) loading rate with the **DC Converter** or **HVDC Converter** in rectifier mode.
- (ii) Nominal and maximum (emergency) loading rate with the **DC Converter** or **HVDC Converter** in inverter mode.
- (iii) Maximum recovery time, to 90% of pre-fault loading, following an AC system fault or severe voltage depression.
- (iv) Maximum recovery time, to 90% of pre-fault loading, following a transient **DC Network** fault.

Harmonic Assessment Information

PC.A.5.4.3.4 **DC Converter** owners and **HVDC System Owners** shall provide such additional further information as required by **The Company** in order that compliance with CC.6.1.5 or ECC.6.1.5 can be demonstrated.

\* Data items marked with an asterisk are already requested under part 1, PC.A.3.3.1, to facilitate an early assessment by **The Company** as to whether detailed stability studies will be required before an offer of terms for a **CUSC Contract** can be made. Such data items have been repeated here merely for completeness and need not, of course, be resubmitted unless their values, known or estimated, have changed.

PC.A.5.5 Response Data For Frequency Changes

The information detailed below is required to describe the actual frequency response capability profile as illustrated in Figure CC.A.3.1 of the **Connection Conditions** or Figure ECC.A.3.1 of the **European Connection Conditions**, and need only be provided for each:

- (i) **Genset** at **Large Power Stations**; and
- (ii) **Generating Unit** (including **Synchronous Generating Units** within a **Synchronous Power Generating Module**), **Power Park Module** (including a **DC Connected Power Park Module**) or **CCGT Module** at a **Medium Power Station** or **DC Converter Station** or **HVDC System** that has agreed to provide **Frequency** response in accordance with a **CUSC Contract**.

In the case of (ii) above for the rest of this PC.A.5.5 where reference is made to **Gensets**, it shall include such **Generating Units** (including **Synchronous Generating Units** within a **Synchronous Power Generating Module**), **CCGT Modules**, **Power Park Modules** (including **DC Connected Power Park Modules**), **HVDC Systems** and **DC Converters** as appropriate, but excludes **OTSDUW Plant and Apparatus** utilising **OTSDUW DC Converters**.

In this PC.A.5.5, for a **CCGT Module** with more than one **Generating Unit**, the phrase **Minimum Generation** or **Minimum Regulating Level** applies to the entire **CCGT Module** operating with all **Generating Units** (including **Synchronous Generating Units** within a **Synchronous Power Generating Module**) **Synchronised** to the **System**. Similarly for a **Power Park Module** (including a **DC Connected Power Park Module**) with more than one **Power Park Unit**, the phrase **Minimum Generation** or **Minimum Regulating Level** applies to the entire **Power Park Module** operating with all **Power Park Units Synchronised** to the **System**.

PC.A.5.5.1 MW Loading Points At Which Data Is Required

Response values are required at six MW loading points (MLP1 to MLP6) for each **Genset**. **Primary** and **Secondary Response** values need not be provided for MW loading points which are below **Minimum Generation** or **Minimum Stable Operating Level**. MLP1 to MLP6 must be provided to the nearest MW.

Prior to the **Genset** being first **Synchronised**, the MW loading points must take the following values :

MLP1	<b>Designed Minimum Operating Level</b> or <b>Minimum Regulating Level</b>
MLP2	<b>Minimum Generation</b> or <b>Minimum Stable Operating Level</b>
MLP3	70% of <b>Registered Capacity</b> or <b>Maximum Capacity</b>
MLP4	80% of <b>Registered Capacity</b> or <b>Maximum Capacity</b>
MLP5	95% of <b>Registered Capacity</b> or <b>Maximum Capacity</b>
MLP6	<b>Registered Capacity</b> or <b>Maximum Capacity</b>

When data is provided after the **Genset** is first **Synchronised**, the MW loading points may take any value between the **Designed Minimum Operating Level** or **Minimum Regulating Level** and **Registered Capacity** or **Maximum Capacity** but the value of the **Designed Minimum Operating Level** or **Minimum Regulating Level** must still be provided if it does not form one of the MW loading points.

PC.A.5.5.2 Primary And Secondary Response To Frequency Fall

**Primary** and **Secondary Response** values for a -0.5Hz ramp are required at six MW loading points (MLP1 to MLP6) as detailed above

PC.A.5.5.3 High Frequency Response To Frequency Rise

**High Frequency Response** values for a +0.5Hz ramp are required at six MW loading points (MLP1 to MLP6) as detailed above.

PC.A.5.5.4 Each **Generator** or **Defence Service Provider** or **Restoration Contractor** or **Non-Embedded Customer** in respect of an **Electricity Storage Module**, shall provide **Frequency response** curves that demonstrate the ability of their **Electricity Storage Modules** to transition from a mode analogous to **Demand** to a mode analogous to generation (excluding **Auxiliary Supplies**) within a period of 20 seconds or less in accordance with the requirements of ECC.6.3.7.2.3, unless the provisions of ECC.6.3.7.2.3.1 apply where the requirements of OC6.6.6. relate.

PC.A.5.6 Mothballed Power Generating Module, Mothballed Generating Unit, Mothballed Power Park Module (including DC Connected Power Park Modules), Mothballed HVDC Systems or Mothballed DC Converter at a DC Converter Station And Alternative Fuel Information



Data identified under this section PC.A.5.6 must be submitted as required under PC.A.1.2 and at **The Company's** reasonable request.

In the case of **Embedded Medium Power Stations** not subject to a **Bilateral Agreement**, **Embedded HVDC Systems** not subject to a **Bilateral Agreement** and **Embedded DC Converter Stations** not subject to a **Bilateral Agreement**, upon request from **The Company** each **Network Operator** shall provide the information required in PC.A.5.6.1, PC.A.5.6.2, PC.A.5.6.3 and PC.A.5.6.4 on respect of such **Embedded Medium Power Stations** and **Embedded DC Converters Stations** and **Embedded HVDC Systems** with their **System**.

PC.A.5.6.1 Mothballed Generating Unit Information

**Generators, HVDC System Owners** and **DC Converter Station** owners must supply with respect to each **Mothballed Power Generating Module, Mothballed Generating Unit, Mothballed Power Park Module** (including a **DC Connected Power Park Module**), **Mothballed HVDC System** or **Mothballed DC Converter** at a **DC Converter Station** the estimated **MW** output which could be returned to service within the following time periods from the time that a decision to return was made:

- < 1 month;
- 1-2 months;
- 2-3 months;
- 3-6 months;
- 6-12 months; and
- >12 months.

The return to service time should be determined in accordance with **Good Industry Practice** assuming normal working arrangements and normal plant procurement lead times. The MW output values should be the incremental values made available in each time period as further described in the **DRC**.

PC.A.5.6.2 **Generators, HVDC System Owners** and **DC Converter Station** owners must also notify **The Company** of any significant factors which may prevent the **Mothballed Power Generating Module, Mothballed Generating Unit, Mothballed Power Park Module** (including **DC Connected Power Park Modules**), **Mothballed HVDC Systems** or **Mothballed DC Converter** at a **DC Converter Station** achieving the estimated values provided under PC.A.5.6.1 above, excluding factors relating to **Transmission Entry Capacity**.

PC.A.5.6.3 Alternative Fuel Information

The following data items must be supplied with respect to each **Generating Unit** (including **Synchronous Generating Units** within a **Synchronous Power Generating Module**) whose main fuel is gas.

For each alternative fuel type (if facility installed):

- (a) Alternative fuel type e.g. oil distillate, alternative gas supply
- (b) For the changeover from main to alternative fuel:
  - Time to carry out off-line and on-line fuel changeover (minutes).
  - Maximum output following off-line and on-line changeover (MW).
  - Maximum output during on-line fuel changeover (MW).
  - Maximum operating time at full load assuming typical and maximum possible stock levels (hours).
  - Maximum rate of replacement of depleted stocks (MWh electrical/day) on the basis of **Good Industry Practice**.
  - Is changeover to alternative fuel used in normal operating arrangements?
  - Number of successful changeovers carried out in the last of **The Company's**

**Financial Year** (choice of 0, 1-5, 6-10, 11-20, >20).

(c) For the changeover back to main fuel:

- Time to carry out off-line and on-line fuel changeover (minutes).
- Maximum output during on-line fuel changeover (MW).

PC.A.5.6.4 **Generators** must also notify **The Company** of any significant factors and their effects which may prevent the use of alternative fuels achieving the estimated values provided under PC.A.5.6.3 above (e.g. emissions limits, distilled water stocks etc.)

PC.A.5.7 System Restoration Related Information

PC.A.5.7.1 Data identified under this section PC.A.5.7.1 must be submitted as required under PC.A.1.2. This information may also be requested by **The Company** during **System Restoration** and should be provided by **Generators, HVDC System Owners** and **DC Converter Station Owners** where reasonably possible. For the avoidance of doubt, **Generators** in this section PC.A.5.7.1 means each **Generator** in respect of their **BM Unit** at any directly connected **Power Station** or **Large Power Station** (excluding **Generators** in respect of **Embedded Medium Power Stations** and **Embedded Small Power Stations**).

The data items/text in (a) and (b) below must be supplied, by each **Generator** and **HVDC System Owner** and **DC Converter Station** owner to **The Company**. In the case of **Generators**, the data supplied should be with respect to each **BM Unit** at any directly connected **Power Station** or **Large Power Station**. For the avoidance of doubt, the data required under PC.A.5.7.1(a) and (b) below, i) does not need to be supplied in respect of **Restoration Contractors Plant** and ii), only needs to be supplied in respect of each **BM Unit** at a **Large Power Station** or any directly connected **Power Station** and does not need to include **Generating Unit** data;

- (a) The expected time for each **BM Unit** to be **Synchronised** following a **Total Shutdown** or **Partial Shutdown**. The assessment should include the **Power Stations** or **HVDC Systems** or **DC Converter Stations** ability to re-synchronise all **BM Units**, if all were running immediately prior to the **Total Shutdown** or **Partial Shutdown** once auxiliary supplies have been restored, or supplies have been restored to the **User's Site** where the **Plant** was running immediately prior to the **Shutdown**) and at time intervals of 12 hours, 24 hours, 36 hours, 48 hours and 72 hours before the **BM Unit** had been **Shutdown**. Additionally this should highlight any specific issues (i.e. those that would have an impact on the **BM Unit's** time to be **Synchronised**) that may arise, as time progresses without external supplies being restored or the availability of primary fuel supplies. In submitting this data, **Generators, HVDC System Owners** and **DC Converter Station** owners should be aware of the requirements in CC.7.11 or ECC.7.11.
- (b) **Block Loading Capability**. This should be provided in either graphical or tabular format showing the estimated block loading capability from 0MW to **Registered Capacity** and the time between each incremental step. Any particular **Active Power** loading points at which the **BM Unit** should be operated until further changes in output can be accommodated should also be identified. The data of each **BM Unit** should be provided for the condition of a **Generating Unit** (which was running immediately prior to the **Shutdown**) and at time intervals of 12 hours, 24 hours, 36 hours, 48 hours and 72 hours before the **BM Unit** had been **Shutdown**. In the case of an **HVDC System** or **DC Converter Station**, data should be provided when the **HVDC System** or **DC Converter Station** (which was running immediately prior to the **Shutdown**) and at time intervals of 12 hours, 24 hours, 36 hours, 48 hours and 72 hours prior to the **HVDC System** or **DC Converter Station** had been **Shutdown**. The block loading assessment should be done against a frequency variation of 47.5Hz – 52Hz.

PC.A.5.7.2 Where a **Network Operator** has a **Distribution Restoration Zone Plan** in place, the data specified in this section shall be submitted as required under PC.A.1.2 by **Network Operators** to **The Company** annually by calendar week 28. This information may also be requested by **The Company** from the relevant **Network Operator** during **System Restoration** and should be provided by **Network Operators** where reasonably practicable. **Restoration Contractors** party to a **Distribution Restoration Zone Plan** shall, where reasonably practicable, submit the relevant information to the **Network Operator** who shall then supply the relevant information to **The Company**. The following data shall be provided;

- (a) The expected time for each **Restoration Contractor's Plant** to **Re-Synchronise** to the **Network Operator's System** following a **Total Shutdown** or **Partial Shutdown**. The assessment should include the **Restoration Contractor's** ability to **Re-Synchronise** all their **Plant**, if all were running immediately prior to the **Total Shutdown** or **Partial Shutdown**. Additionally, the data and supporting text should highlight any specific issues (eg those that would affect the time before which the **Restoration Contractor's Plant** could be energised) that may arise as time progresses from **Shutdown** without external supplies being restored or the availability of primary fuel supplies..
- (b) The **Restoration Contractor's Plants Block Loading Capability** as required in PC.A.5.7.1(b).

PC.A.5.7.3 From 31<sup>st</sup> December 2026 onwards, all **Users** and **Restoration Contractors** are required to confirm annually they comply with the applicable requirements of OC5.7. In the case of **Generators, HVDC System Owners, DC Converter owners, Non-Embedded Customers,** and **Network Operators** this confirmation shall be provided in their Week 24 submission. From 1<sup>st</sup> January 2024 until 31<sup>st</sup> December 2026, evidence to support the work **Generators, HVDC System Owners, DC Converter owners, Non-Embedded Customers,** and **Network Operators** are carrying out to achieve these requirements on or after 31<sup>st</sup> December 2026 shall be provided in their Week 24 submission.

PC.A.5.7.4 From 1<sup>st</sup> January 2025 onwards, **Restoration Contractors, Generators, HVDC System Owners** and **DC Converter owners,** shall supply the governor setting information in accordance with the applicable requirements of CC.6.3.7(g), (h) and (i) or ECC.6.3.7.3.8.

PC.A.5.8 Grid Forming Related Information

PC.A.5.8.1 The following data need only be supplied by **Users** (be they a **GB Code User** or **EU Code User**) or **Non-CUSC Parties** who wish to offer a **Grid Forming Capability** as provided for ECC.6.3.19.3. Where such a **Grid Forming Capability** is provided then the following data items and models are to be supplied.

- (i) Each **GBGF-I** shall be designed so as not to interact and affect the operation, performance, safety or capability of other **User's Plant** and **Apparatus** connected to the **Total System**. To achieve this requirement, each **User** shall be required to submit a **Network Frequency Perturbation Plot** and **Nichols Chart** (or equivalent as agreed with **The Company**) which shall be assessed in accordance with the requirements of ECP.A.3.9.3.

Each **User** or **Non-CUSC Party** is required to supply a high level equivalent architecture diagram of their **Grid Forming Plant** as shown in Figure PC.A.5.8.1 together with the equivalent linear classical block diagram model (using the Laplace Operator) of their **Grid Forming Plant** which should preferably be in the general form shown in Figure PC.A.5.8.1 (a) or Figure PC.A.5.8.1 (b). When submitting either Figure PC.A.5.8.1 (a) or Figure PC.A.5.8.1 (b), each **User** or **Non-CUSC Party** can use their own design, that may be very different to Figures PC.A.5.8.1 (a) or PC.A.5.8.1 (b), but should contain all relevant functions that can include simulation models and other equivalent data and documentation.

Each **User** or **Non-CUSC Party** shall provide a model of their **Grid Forming Plant** which provides a true and accurate reflection of its **Grid Forming Capability**.

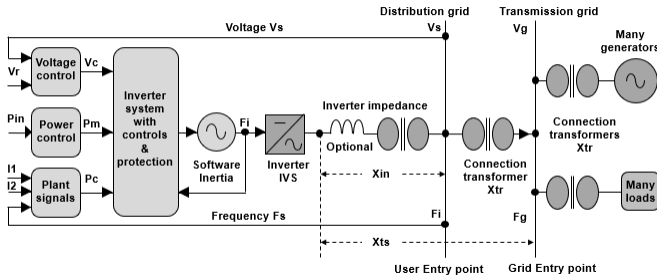

Figure PC.A.5.8.1

**Typical simulation model 1**

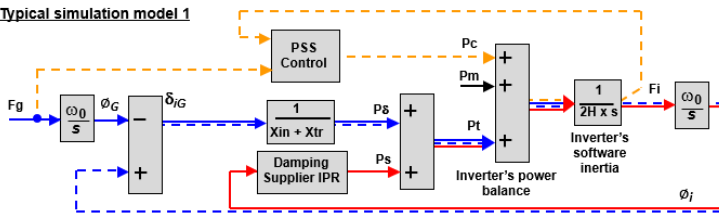

Figure PC.A.5.8.1 (a) Preferred simplified diagram of a **GBGF-I** with a **Power System Stabiliser "PSS"** that can add damping to the **GBGF-I's** closed loop function shown by the solid red line and the dotted blue line.

**Typical simulation model 2**

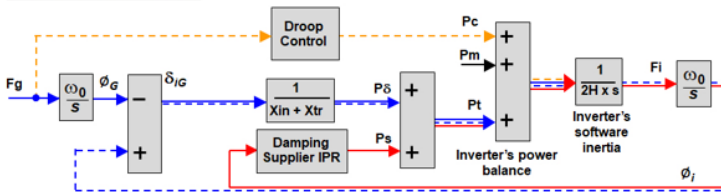

Figure PC.A.5.8.1 (b) – Preferred simplified diagram of a system with a droop control ability that can add **Control-Based Active Droop Power**. This diagram does not add extra closed loop damping to the **GBGF-I's** closed loop function shown by the solid red line and the dotted blue line.

- (ii) In order to participate in the **Grid Forming Capability** market, **User's** and **Non-CUSC Parties** are required to provide data of their **GBGF-I** in accordance with Figures PC.A.5.8.1(a) and PC.A.5.8.1(b). **Users** and **Non-CUSC Parties** in respect of **Grid Forming Plants** should indicate if the data is submitted on a unit or aggregated basis. Table PC.A.5.8.1(a) defines the notation used in Figure PC.5.8.1

Parameter	Symbol	Units
The primary reactance of the <b>Grid Forming Unit</b> , in pu.	$X_{in}$ or $X_{ts}$	pu on MVA Rating of <b>Grid Forming Unit</b>
The additional reactance, in pu, between the terminals of the <b>Grid Forming Unit</b> and the <b>Grid Entry Point</b> or <b>User System Entry Point</b> (if <b>Embedded</b> ).	$X_{tr}$	pu on MVA Rating of <b>Grid Forming Unit</b>
The rated angle between the <b>Internal Voltage Source</b> and the input terminals of the <b>Grid Forming Unit</b> .		radians
The rated angle between the <b>Internal Voltage Source</b> and <b>Grid Entry Point</b> or <b>User System Entry Point</b> (if <b>Embedded</b> ).		radians
The rated voltage and phase of the <b>Internal Voltage Source</b> of the <b>Grid Forming Unit</b> .		Voltage - pu Phase - radians
The rated electrical angle between current and voltage at the input to the Grid transformer.		radians

Table PC.A.5.8.1

- (iii) In order to participate in a **Grid Forming Capability** market, **User's** and **Non-CUSC Parties** are also required to provide the data of their **GBGF-I** in accordance with Table PC.A.5.8.1.2 to **The Company**. The details and arrangements for **Users** and **Non-CUSC Parties** participating in this market shall be published on **The Company's Website**.

Quantity	Units	Range (where Applicable)	User Defined Parameter
Type of <b>Grid Forming Plant</b> (eg <b>Generating Unit</b> , <b>Electricity Storage Module</b> , <b>Dynamic Reactive Compensation Equipment</b> etc)	N/A		

Maximum Continuous Rating at <b>Registered Capacity or Maximum Capacity</b>	MVA		
Primary reactance $X_{in}$ or $X_{ts}$ (see Table PC.A.5.8.1)	pu on MVA		
Additional reactance $X_{tr}$ (See Table PC.A.5.8.1)	pu on MVA		
<b>Maximum Capacity</b>	MW		
<b>Active ROCOF Response Power</b> (MW) injected or absorbed at 1Hz/s <b>System Frequency</b> change (which is the maximum frequency change for linear operation of the <b>Grid Forming Plant</b> )	MW		
<b>Phase Jump Angle Withstand</b>	degrees		60 degrees specified
<b>Phase Jump Angle limit</b>	degrees		5 degrees recommended
<b>Phase Jump Power</b> (MW) at the rated angle	MW		
<b>Defined Active Damping Power for a Grid Oscillation Value</b> of 0.05 Hz peak to peak at 1 Hz	MW		
The cumulative energy delivered for a 1Hz/s <b>System Frequency</b> fall from 52 Hz to 47 Hz. This is the total <b>Active Power</b> transient output of the <b>Grid Forming Plant</b>	MWs or MJ		
<b>Inertia Constant (H)</b> using equation 1 or declared in accordance with the simulation results of ECP.A.3.9.4	MWs/MVA		
<b>Inertia Constant (He)</b> using equation 2 or declared in accordance with the simulation results of ECP.A.3.9.4	MWs/MVA		
Continuous Overload Capability	% on MVA		
Short Term duration Overload capability			
Duration of Short Term Overload Capability	s		
<b>Peak Current Rating</b>	Pu		

Nominal <b>Grid Entry Point</b> or <b>User System Entry Point</b> voltage	kV		
<b>Grid Entry Point</b> or <b>User System Entry Point</b>	- Location		
Continuous or defined time duration MVA Rating	MVA		
Continuous or defined time duration MW Rating	MW		
For a <b>GBGF-I</b> the inverters maximum <b>Internal Voltage Source (IVS)</b> for the worst case condition – for example operation at maximum exporting <b>Reactive Power</b> at the maximum AC <b>System</b> voltage	pu		
Maximum Three Phase Short Circuit Infeed at <b>Grid Entry Point</b> or <b>User System Entry Point</b>	kA		
Maximum Single Phase Short Circuit Infeed at <b>Grid Entry Point</b> or <b>User System Entry Point</b>	kA		
Will the <b>Grid Forming Plant</b> contribute to any other form of commercial service – for example Dynamic Containment, Firm Frequency Response,	Details to be provided		
<b>Equivalent Damping Factor.</b>	Z		0.2 to 5.0 allowed

Table PC.A.5.8.2

$H = \text{Installed MWs} / \text{Rated installed MVA}$

(equation 1)

$H_e = (\text{Active ROCOF Response Power at 1 Hz} / s \times \text{System Frequency}) / (\text{Installed MVA} \times 2)$

(equation 2)

PC.A.6 [USERS' SYSTEM DATA](#)

PC.A.6.1 [Introduction](#)

PC.A.6.1.1 Each **User**, whether connected directly via an existing **Connection Point** to the **National Electricity Transmission System** or seeking such a direct connection, or providing terms for connection of an **Offshore Transmission System** to its **User System** to **The Company** or undertaking **OTSDUW**, shall provide **The Company** with data on its **User System** or **OTSDUW Plant and Apparatus** which relates to the **Connection Site** containing the **Connection Point** (or **Interface Points** or **Connection Points** in the case of **OTSUA**) both current and forecast, as specified in PC.A.6.2 to PC.A.6.6.

PC.A.6.1.2 Each **User** must reflect the system effect at the **Connection Site(s)** of any third party **Embedded** within its **User System** whether existing or proposed.

PC.A.6.1.3 PC.A.6.2, and PC.A.6.4 to PC.A.6.7 consist of data which is only to be supplied to **The Company** at **The Company's** reasonable request. In the event that **The Company** identifies a reason for requiring this data, **The Company** shall write to the relevant **User(s)**, requesting the data, and explaining the reasons for the request. If the **User(s)** wishes, **The Company** shall also arrange a meeting at which the request for data can be discussed, with the objective of identifying the best way in which **The Company's** requirements can be met. In respect of **EU Code User(s)** only, **The Company** may request the need for electromagnetic transient simulations at **The Company's** reasonable request. **Users** with **EU Grid Supply Points** may be required to provide electromagnetic transient simulations in relation to those **EU Grid Supply Points** at **The Company's** reasonable request.

Where **The Company** makes a request to a **User** for dynamic models under PC.A.6.7, each relevant **User** shall ensure that the models supplied in respect of their **Plant** and **Apparatus** reflect the true and accurate behaviour of the **Plant** and **Apparatus** as built and verified through the **Compliance Processes (CP's)** or **European Compliance Processes (ECP)**.

#### PC.A.6.2 Transient Overvoltage Assessment Data

PC.A.6.2.1 It is occasionally necessary for **The Company** to undertake transient overvoltage assessments (e.g. capacitor switching transients, switchgear transient recovery voltages, etc). At **The Company's** reasonable request, each **User** is required to provide the following data with respect to the **Connection Site** (and in the case of **OTSUA**, **Interface Points** and **Connection Points**), current and forecast, together with a **Single Line Diagram** where not already supplied under PC.A.2.2.1, as follows:

- (a) busbar layout plan(s), including dimensions and geometry showing positioning of any current and voltage transformers, through bushings, support insulators, disconnectors, circuit breakers, surge arresters, etc. Electrical parameters of any associated current and voltage transformers, stray capacitances of wall bushings and support insulators, and grading capacitances of circuit breakers;
- (b) Electrical parameters and physical construction details of lines and cables connected at that busbar. Electrical parameters of all plant e.g., transformers (including neutral earthing impedance or zig-zag transformers, if any), series reactors and shunt compensation equipment connected at that busbar (or to the tertiary of a transformer) or by lines or cables to that busbar;
- (c) Basic insulation levels (BIL) of all **Apparatus** connected directly, by lines or by cables to the busbar;
- (d) characteristics of overvoltage **Protection** devices at the busbar and at the termination points of all lines, and all cables connected to the busbar;
- (e) fault levels at the lower voltage terminals of each transformer connected directly or indirectly to the **National Electricity Transmission System** (including **OTSUA** at each **Interface Point** and **Connection Point**) without intermediate transformation;
- (f) the following data is required on all transformers operating at **Supergrid Voltage** throughout **Great Britain** and, in Scotland and **Offshore**, also at 132kV or greater (including **OTSUA**): three or five limb cores or single phase units to be specified, and operating peak flux density at nominal voltage;



- (g) an indication of which items of equipment may be out of service simultaneously during **Planned Outage** conditions.

PC.A.6.3 User's Protection Data

PC.A.6.3.1 Protection

The following information is required which relates only to **Protection** equipment which can trip or inter-trip or close any **Connection Point** circuit-breaker or any **Transmission** circuit-breaker (or in the case of **OTSUA**, any **Interface Point** or **Connection Point** circuit breaker). This information need only be supplied once, in accordance with the timing requirements set out in PC.A.1.4(b), and need not be supplied on a routine annual basis thereafter, although **The Company** should be notified if any of the information changes;

- (a) a full description, including estimated settings, for all relays and **Protection** systems installed or to be installed on the **User's System**;
- (b) a full description of any auto-reclose facilities installed or to be installed on the **User's System**, including type and time delays;
- (c) a full description, including estimated settings, for all relays and **Protection** systems or to be installed on the generator, generator transformer, **Station Transformer** and their associated connections;
- (d) for **Generating Units** (including **Synchronous Generating Units** forming part of a **Synchronous Power Generating Module** but excluding **Power Park Units**) or **Power Park Modules** (including **DC Connected Power Park Modules**) or **HVDC Systems** or **DC Converters** at a **DC Converter Station** or **OTSDUW Plant and Apparatus** having (or intended to have) a circuit breaker at the generator terminal voltage, clearance times for electrical faults within the **Generating Unit** (including **Synchronous Generating Units** forming part of a **Synchronous Power Generating Module** but excluding a **Power Park Unit**) or **Power Park Module** (including **DC Connected Power Park Modules**) zone, or within the **OTSDUW Plant and Apparatus**;
- (e) the most probable fault clearance time for electrical faults on any part of the **User's System** directly connected to the **National Electricity Transmission System** including **OTSDUW Plant and Apparatus**; and
- (f) in the case of **OTSDUW Plant and Apparatus**, synchronisation facilities and delayed auto reclose sequence schedules (where applicable).
- (g) **Restoration Contractors** and **Network Operators** shall provide the above **Protection** data where different settings are used in respect of their **Plant and Apparatus** which are associated with a **Restoration Plan**.

PC.A.6.4 Harmonic Studies

PC.A.6.4.1 It is occasionally necessary for **The Company** to evaluate the production/magnification of harmonic distortion on the **National Electricity Transmission System** and **User's Systems** (and **OTSUA**), especially when **The Company** is connecting equipment such as capacitor banks. At **The Company's** reasonable request, each **User** is required to submit data with respect to the **Connection Site** (and in the case of **OTSUA**, each **Interface Point** and **Connection Point**), current and forecast, and where not already supplied under PC.A.2.2.4 and PC.A.2.2.5, as follows:

PC.A.6.4.2 Overhead lines and underground cable circuits of the **User's Subtransmission System** must be differentiated and the following data provided separately for each type:

Positive phase sequence resistance;  
Positive phase sequence reactance;  
Positive phase sequence susceptance;

and for all transformers connecting the **User's Subtransmission System** and **OTSDUW Plant and Apparatus** to a lower voltage:

Rated MVA;  
Voltage Ratio;  
Positive phase sequence resistance;  
Positive phase sequence reactance;

and at the lower voltage points of those connecting transformers:

Equivalent positive phase sequence susceptance;  
Connection voltage and MVA rating of any capacitor bank and component design parameters if configured as a filter;  
Equivalent positive phase sequence interconnection impedance with other lower voltage points;  
The minimum and maximum **Demand** (both MW and MVA) that could occur;  
Harmonic current injection sources in Amps at the Connection voltage points. Where the harmonic injection current comes from a diverse group of sources, the equivalent contribution may be established from appropriate measurements;  
Details of traction loads, eg connection phase pairs, continuous variation with time, etc;  
An indication of which items of equipment may be out of service simultaneously during **Planned Outage** conditions.

PC.A.6.5

#### Voltage Assessment Studies

It is occasionally necessary for **The Company** to undertake detailed voltage assessment studies (e.g., to examine potential voltage instability, voltage control co-ordination or to calculate voltage step changes). At **The Company's** reasonable request, each **User** is required to submit the following data where not already supplied under PC.A.2.2.4 and PC.A.2.2.5:

For all circuits of the User's Subtransmission System (and any OTSUA):-

Positive Phase Sequence Reactance;  
Positive Phase Sequence Resistance;  
Positive Phase Sequence Susceptance;  
MVA rating of any reactive compensation equipment;

and for all transformers connecting the **User's Subtransmission System** to a lower voltage (and any **OTSUA**):

Rated MVA;  
Voltage Ratio;  
Positive phase sequence resistance;  
Positive Phase sequence reactance;  
Tap-changer range;  
Number of tap steps;  
Tap-changer type: on-load or off-circuit;  
AVC/tap-changer time delay to first tap movement;

AVC/tap-changer inter-tap time delay;

and at the lower voltage points of those connecting transformers (and any **OTSUA**):-

Equivalent positive phase sequence susceptance;

MVA<sub>r</sub> rating of any reactive compensation equipment;

Equivalent positive phase sequence interconnection impedance with other lower voltage points;

The maximum **Demand** (both MW and MVA<sub>r</sub>) that could occur;

Estimate of voltage insensitive (constant power) load content in % of total load at both winter peak and 75% off-peak load conditions.

PC.A.6.6 Short Circuit Analysis

PC.A.6.6.1 Where prospective short-circuit currents on **Transmission** equipment are greater than 90% of the equipment rating, and in **The Company's** reasonable opinion more accurate calculations of short-circuit currents are required, then at **The Company's** request each **User** is required to submit data with respect to the **Connection Site** (and in the case of **OTSUA**, each **Interface Point** and **Connection Point**), current and forecast, and where not already supplied under PC.A.2.2.4 and PC.A.2.2.5, as follows:

PC.A.6.6.2 For all circuits of the **User's Subtransmission System** (and any **OTSUA**):

Positive phase sequence resistance;

Positive phase sequence reactance;

Positive phase sequence susceptance;

Zero phase sequence resistance (both self and mutuals);

Zero phase sequence reactance (both self and mutuals);

Zero phase sequence susceptance (both self and mutuals);

and for all transformers connecting the **User's Subtransmission System** to a lower voltage (and any **OTSUA**):

Rated MVA;

Voltage Ratio;

Positive phase sequence resistance (at max, min and nominal tap);

Positive Phase sequence reactance (at max, min and nominal tap);

Zero phase sequence reactance (at nominal tap);

Tap changer range;

Earthing method: direct, resistance or reactance;

Impedance if not directly earthed;

and at the lower voltage points of those connecting transformers (and any **OTSUA**):

The maximum **Demand** (in MW and MVA<sub>r</sub>) that could occur;

Short-circuit infeed data in accordance with PC.A.2.5.6 unless the **User's** lower voltage network runs in parallel with the **User's Subtransmission System**, when to prevent double counting in each node infeed data, a  $\pi$  equivalent comprising the data items of PC.A.2.5.6 for each node together with the positive phase sequence interconnection impedance between the nodes shall be submitted.

PC.A.6.7 Dynamic Models

PC.A.6.7.1 It is occasionally necessary for **The Company** to evaluate the dynamic performance of **User's Plant and Apparatus** at each **EU Grid Supply Point** or in the case of **EU Code Users**, their **System**. At **The Company's** reasonable request and as agreed between **The Company** and the relevant **Network Operator** or **Non-Embedded Customer**, each **User** is required to provide the following data. Where such data is required, **The Company** will work with the **Network Operator** or **Non-Embedded Customer** to establish the scope of the dynamic modelling work and share the required information where it is available:-

- (a) Dynamic model structure and block diagrams including parameters, transfer functions and individual elements (as applicable);
- (b) Power control functions and block diagrams including parameters, transfer functions and individual elements (as applicable);
- (c) Voltage control functions and block diagrams including parameters, transfer functions and individual elements (as applicable);
- (d) Converter control models and block diagrams including parameters, transfer functions and individual elements (as applicable).

PC.A.7 ADDITIONAL DATA FOR NEW TYPES OF POWER STATIONS, DC CONVERTER STATIONS, OTSUA AND CONFIGURATIONS

Notwithstanding the **Standard Planning Data** and **Detailed Planning Data** set out in this Appendix, as new types of configurations and operating arrangements of **Power Stations, HVDC Systems, DC Converter Stations** and **OTSUA** emerge in future, **The Company** may reasonably require additional data to represent correctly the performance of such **Plant and Apparatus** on the **System**, where the present data submissions would prove insufficient for the purpose of producing meaningful **System** studies for the relevant parties.

### PART 3 - DETAILED PLANNING DATA

PC.A.8 To allow a **User** to model the **National Electricity Transmission System**, **The Company** will provide, upon request, the following **Network Data** to **Users**, calculated in accordance with **Good Industry Practice**:

To allow a **User** to assess undertaking **OTSDUW** and except where provided for in Appendix F, **The Company** will provide upon request the following **Network Data** to **Users**, calculated in accordance with **Good Industry Practice**:

PC.A.8.1 Single Point of Connection

For a **Single Point of Connection** to a **User's System** (and **OTSUA**), as a Transmission System voltage source, the data (as at the HV side of the **Point of Connection** (and in the case of **OTSUA**, each **Interface Point** and **Connection Point**) reflecting data given to **The Company** by **Users**) will be given to a **User** as follows:

The data items listed under the following parts of PC.A.8.3:

(a) (i), (ii), (iii), (iv), (v) and (vi) and the data items shall be provided in accordance with the detailed provisions of PC.A.8.3 (b) - (e).

PC.A.8.2 Multiple Point of Connection

For a **Multiple Point of Connection** to a **User's System** equivalents suitable for use in loadflow and fault level analysis shall be provided. These equivalents will normally be in the form of a  $\pi$  model or extension with a source (or demand for a loadflow equivalent) at each node and a linking impedance. The boundary nodes for the equivalent shall be either at the **Connection Point** (and in the case of **OTSDUW**, each **Interface Point** and **Connection Point**) or (where **The Company** agrees) at suitable nodes (the nodes to be agreed with the **User**) within the **National Electricity Transmission System**. The data at the **Connection Point** (and in the case of **OTSDUW**, each **Interface Point** and **Connection Point**) will be given to a **User** as follows:

The data items listed under the following parts of PC.A.8.3:-

(a) (i), (ii), (iv), (v), (vi), (vii), (viii), (ix), (x) and (xi)

and the data items shall be provided in accordance with the detailed provisions of PC.A.8.3 (b) - (e).

When an equivalent of this form is not required **The Company** will not provide the data items listed under the following parts of PC.A.8.3:-

(a) (vii), (viii), (ix), (x) and (xi)

PC.A.8.3 Data Items

(a) The following is a list of data utilised in this part of the **PC**. It also contains rules on the data which generally apply.

- (i) symmetrical three-phase short circuit current infeed at the instant of fault from the **National Electricity Transmission System**, ( $I_1''$ );
- (ii) symmetrical three-phase short circuit current from the **National Electricity Transmission System** after the subtransient fault current contribution has substantially decayed, ( $I_1'$ );
- (iii) the zero sequence source resistance and reactance values at the **Point of Connection** (and in case of **OTSUA**, each **Interface Point** and **Connection Point**), consistent with the maximum infeed below;
- (iv) the pre-fault voltage magnitude at which the maximum fault currents were calculated;
- (v) the positive sequence X/R ratio at the instant of fault;
- (vi) the negative sequence resistance and reactance values of the **National Electricity Transmission System** seen from the **Point of Connection** (and in case of **OTSUA**, each **Interface Point** and **Connection Point**), if substantially different from the

values of positive sequence resistance and reactance which would be derived from the data provided above;

- (vii) the initial positive sequence resistance and reactance values of the two (or more) sources and the linking impedance(s) derived from a fault study constituting the ( $\pi$ ) equivalent and evaluated without the **User** network and load and where appropriate without elements of the **National Electricity Transmission System** between the **User** network and agreed boundary nodes (and in case of **OTSUA**, each **Interface Point** and **Connection Point**);
  - (viii) the positive sequence resistance and reactance values of the two (or more) sources and the linking impedance(s) derived from a fault study, considering the short circuit current contributions after the subtransient fault current contribution has substantially decayed, constituting the ( $\pi$ ) equivalent and evaluated without the **User** network and load, and where appropriate without elements of the **National Electricity Transmission System** between the **User** network and agreed boundary nodes (and in case of **OTSUA**, each **Interface Point** and **Connection Point**);
  - (ix) the corresponding zero sequence impedance values of the ( $\pi$ ) equivalent produced for use in fault level analysis;
  - (x) the **Demand** and voltage at the boundary nodes and the positive sequence resistance and reactance values of the linking impedance(s) derived from a loadflow study considering **National Electricity Transmission System** peak **Demand** constituting the ( $\pi$ ) loadflow equivalent; and,
  - (xi) where the agreed boundary nodes are not at a **Connection Point** (and in case of **OTSUA**, **Interface Point** or **Connection Point**), the positive sequence and zero sequence impedances of all elements of the **National Electricity Transmission System** between the **User** network and agreed boundary nodes that are not included in the equivalent (and in case of **OTSUA**, each **Interface Point** and **Connection Point**).
- (b) To enable the model to be constructed, **The Company** will provide data based on the following conditions.
- (c) The initial symmetrical three phase short circuit current and the transient period three phase short circuit current will normally be derived from the fixed impedance studies. The latter value should be taken as applying at times of 120ms and longer. Shorter values may be interpolated using a value for the subtransient time constant of 40ms. These fault currents will be obtained from a full **System** study based on load flow analysis that takes into account any existing flow across the point of connection being considered.
- (d) **The Company** will provide the appropriate supergrid transformer data for the **National Electricity Transmission System** associated with equivalent voltage source data.
- (e) The positive sequence X/R ratio and the zero sequence impedance value will correspond to **The Company's** source network only, that is with the section of network if any with which the equivalent is to be used excluded. These impedance values will be derived from the condition when all **Generating Units** (including **Synchronous Generating Units** forming part of a **Synchronous Power Generating Module**) are **Synchronised** to the **National Electricity Transmission System** or a **User's System** and will take account of active sources only including any contribution from the load to the fault current. The passive component of the load itself or other system shunt impedances should not be included.
- (f) A **User** may at any time, in writing, specifically request for an equivalent to be prepared for an alternative **System** condition, for example where the **User's System** peak does not correspond to the **National Electricity Transmission System** peak, and **The Company** will, insofar as such request is reasonable, provide the information as soon as reasonably practicable following the request.

- PC.A.9      **CONTROL SYSTEM MODEL REQUIREMENTS FOR USERS**
- PC.A.9.1      **OBJECTIVE**
- PC.A.9.1.1      Control and protection system models, along with other **Plant** and **Apparatus** information are required by this **PC**, with supporting documentation provided to **The Company** in order for **The Company** and **Transmission Licensees** to assess the impact of the **User's Plant and Apparatus** on the transient performance, security and stability of the **Transmission System**.
- PC.A.9.1.2      The control and protection system models submitted by the **User** shall be representative of the **User's Plant and Apparatus** at the **Connection Point** appropriate to the type of model eg. RMS or EMT. All control and protection system models must take into account all communication, controller and processing delays relevant to modelling the performance of the **User's Plant and Apparatus**. If all **Power Park Units** or **DC Convertors** or **HVDC Converters** contained within the **Users Plant and Apparatus** are not identical, the control system model shall account for this by accurately representing the overall performance of the **Users Plant and Apparatus** at the **Connection Point**.
- PC.A.9.1.3      The control and protection system models shall include representation of all relevant functionality required by the Grid Code including services provided to **The Company**. For example, this includes voltage control, LFSM-O, LFSM-U, frequency response, fault ride through, fast fault current injection, protection and automatic switching of shunt devices. Where modes of operation are selectable, the ability to select the mode of operation shall be included within the control system model. Additional guidance on relevant functionality will be published on **The Company** website.
- PC.A.9.2.      **SCOPE**
- PC.A.9.2.1      All **Users** shall provide root mean-square (RMS) models which represent the **Users Plant and Apparatus** and controllers in balanced, RMS, positive phase-sequence, time domain studies.
- PC.A.9.2.2      All **Generators**, **HVDC Converter Station Owners**, or **HVDC System Owners** directly connected to the **Transmission System** or **Generators with Large Power Stations** and **HVDC Converter Station Owners** or **HVDC System Owners with DC Converter Stations** or **HVDC Systems** embedded within a **User** system which employ convertors/invertors to import or export power to or from the **System** shall provide Electro-Magnetic Transient (EMT) models which represent the **Users Plant and Apparatus** in electromagnetic transient studies on the transmission and distribution system. For the avoidance of doubt this includes **Generators** who own and operate a **Power Park Module** comprising doubly fed induction generators and may include the excitation and governor control systems associated with **Synchronous Generating Units** if these impact on the types of study described on **The Company** website.
- PC.A.9.2.3      **The Company** may specify requirements for other models in the **Bilateral Agreement** if required for specific connections in accordance with good industry practice. For example Real Time Dynamic Simulator (RTDS) Models may be required for protection co-ordination.
- PC.A.9.3      **Balanced Root Mean Squared (RMS) Control System Model**
- PC.A.9.3.1      The balanced, root mean-square positive sequence time-domain models shall be able to calculate how aspects, (including but not limited to; **Active Power** and **Reactive Power**) of the **User's Plant and Apparatus** vary due to changes in **System Frequency** and voltage at the **Connection Point**.
- PC.A.9.3.2      The RMS models shall include all electrical and mechanical phenomena that impact on the **Active Power** and/or **Reactive Power** of the **User's Plant and Apparatus** for sub-transient, transient and synchronous dynamics within the context of an RMS study assumptions up to and including **Primary** and **Secondary Response** timeframes or when post-event steady state conditions have been achieved.
- PC.A.9.3.3      The **User** shall provide RMS models in the software package specified in PC.A.9.8.1.

- PC.A.9.3.4 The RMS models maybe either a User specific model or a standard open-source models, such as a standard WECC, IEEE or IEC control system model available in the software format as specified by **The Company** provided this model represents the **User's Plant and Apparatus** at the **Connection Point**. Where the **User** is referencing a standard model, the **User** will submit an unambiguous reference to the model and a full set of parameters for the control system model representing the control system performance of the real **Plant and Apparatus**.
- PC.A.9.3.4.1 Where a **User** specific model is provided sufficient information shall be provided by the **User** to allow for **The Company** to redevelop RMS models in the event of future software environment changes or version updates. All models shall be accompanied with appropriate documentation with sufficient detail as specified and deemed complete by **The Company** (such agreement not to be unreasonably withheld).
- PC.A.9.3.4.2 Where a **User** specific model is provided the **User** shall provide information:
- (i) a full description of the models structure, functionality and the **User's Plant and Apparatus** represented.
  - (ii) inputs/outputs and functionality,
  - (iii) the information described in PC.A.5 relevant to the technology modelled.
- PC.A.9.3.5 **The Company** may, when necessary, require the **User** to provide details of the proper operation of its complete RMS system representation or to facilitate its understanding of the results of a RMS dynamic simulation or request additional information concerning the RMS control system model. This should take place no later than the issuance of the FON.
- PC.A.9.3.5 The performance requirements for the RMS models are included in Appendix PC.A.9.8
- PC.A.9.4 **Electromagnetic Transient (EMT) Model**
- PC.A.9.4.1 The three-phase electromagnetic transient control and supporting informtion shall include all material aspects of the **User's Plant and Apparatus** that affect the voltage and current outputs, including those of the control and protection response from the **User's Plant and Apparatus**. The models shall represent phenomena that materially affect the voltage and **Frequency** on the **Total System** over timeframes of sub-cycle up to 50 cycles including, but not limited to, switching electronic devices, transformer saturation and equipment energisation.
- PC.A.9.4.2 The **User** shall provide EMT models in the software package specified in PC.A.9.9.1.
- PC.A.9.4.3 The performance requirements for the EMT control system model are included in Appendix PC.A.9.9
- PC.A.9.5 **Replica Control Systems, RTDS, RSCAd**
- PC.A.9.5.1 Where required by the Bilateral Agreement, the **User** shall provide replica and/or suitable Real Time Dynamic Simulator models. The details of any such rmodels will be included in the Bilateral Agreement.
- PC.A.9.6 **CONFIDENTIALITY AND SHARING**
- PC.A.9.6.1 CONFIDENTIALITY AND SHARING RMS TYPE MODELS
- PC.A.9.6.1.1 The models, supporting documentation and associated data are provided to **The Company** in order to carry out its duties to meet its **Transmission Licence** and Grid Code obligations. In that regard, **the Company** is entitled to share the models, supporting documentation and associated data with the **Transmission Licensees**. **The Company** and/or **Transmission Licensees** may share the models with companies/contractors employed by **the Company** or **Transmission Licensees** to carry out licensed activities. Where such data is shared with third parties working with **The Company** or **Transmission Licensees**, this data will be shared as provided in GC.12.



- PC.A.9.6.1.2 It is the responsibility of the **User** to provide the RMS models, supporting documentation and associated data to **The Company**. **The Company** will accept the models, supporting documentation and associated data from a manufacturer as a **Manufacturers Data and Performance Report** (See ECP.10). **The Company** will only accept this information from a third party manufacturer provided the third party manufacturer agrees to enter into **The Company's** standard confidentiality agreement for **Users** for sharing of the model as outlined in PC.A.9.6.1. In the event the third party manufacturer is unable to enter into **The Company's** standard confidentiality agreement, the **User** shall be responsible for the provision of the RMS models, supporting documentation and associated data to **The Company**.
- PC.A.9.6.1.3 It may also be necessary for **The Company** to share a representative RMS model with another **User** to comply with applicable Grid Code requirements (e.g. ECC.6.3.17.1.5 and ECC.6.3.17.2.3) and Bilateral Agreement. For these purposes the **User** must recorded in the **Compliance Statements** either:
- (i) A declaration that the models submitted for compliance purposes may be shared; or,
  - (ii) provide an equivalent encrypted version of the model that may be shared. In this event the **User** shall demonstrate that the performance of the models and the encrypted model are comparable.
- PC.A.9.6.1.4 The **User** shall notify **The Company** of any changes to RMS models in accordance with PC.A.1.2. Unless specified otherwise in the **Bilateral Agreement**, RMS models must be submitted:
- (i) at least 3 months prior to date requested for issue of the **Interim Operational Notification**
  - (ii) at least 1 month prior to date of issue of a **Limited Operational Notification** for the **Users Plant and Apparatus**.
- PC.A.9.6.2 CONFIDENTIALITY AND SHARING EMT TYPE MODELS
- PC.A.9.6.2.1 The EMT model, supporting documentation and associated data are provided to **The Company** in order to carry out its duties to meet its **Transmission Licence** and Grid Code obligations. In that regard, **the Company** is entitled to share the EMT models, supporting documentation and associated data with the **Transmission Licensees**. **The Company** and/or **Transmission Licensees** may share the EMT model with companies/contractors employed by **the Company** or **Transmission Licensees** to carry out licensed activities. Where such data is shared with third parties working with **The Company** or **Transmission Licensees**, this data will be shared and protected as provided in GC.12.
- PC.A.9.6.2.2 It is the responsibility of the **User** to provide the EMT models, supporting documentation and associated data to **The Company**. **The Company** will accept the EMT models, supporting documentation and associated data from a manufacturer as a **Manufacturers Data and Performance Report** (See ECP.10). **The Company** will only accept this information from a third party manufacturer provided the third party manufacturer agrees to enter into **The Company's** standard confidentiality agreement for **Users** for sharing of the model as outlined in PC.A.9.6.2. In the event the third party manufacturer is unable to enter into **The Company's** standard confidentiality agreement, the **User** shall be responsible for the provision of the EMT models, supporting documentation and associated data to **The Company**.
- PC.A.9.6.2.3 It may be necessary for **The Company** to share a representative EMT model with another **User** to comply with applicable Grid Code requirements (e.g. ECC.6.3.17.1.5 and ECC.6.3.17.2.3) and Bilateral Agreement. For these purposes the **User** must record in the **Compliance Statements** either:
- (i) a declaration that the EMT model submitted for compliance purposes (PC.A.9.6.2.1) may be shared with another **User** for the purpose of fulfilling relevant Grid Code requirements; or,

- (ii) provide an equivalent EMT model that maybe shared with another **User** for the purpose of fulfilling relevant Grid Code requirements. In this event the **User** shall declare that the performance of the equivalent EMT model is adequate for the purposes of fulfilling relevant Grid Requirements as published on **The Company** website.

PC.A.9.6.2.4 Where it is necessary for **The Company** to share a representative EMT model with another **User**, the **User** in receipt of the model shall:

- (i) limit of the use of the EMT model to a specific purpose agreed with **The Company** (e.g. simulation requirements to demonstrate compliance with Grid Code including ECC.6.3.17.1 and ECC.6.3.17.2 and Bilateral Agreement)
- (ii) control access to the EMT model to only those individuals who are strictly necessary for the execution of the specific purpose.
- (iii) establish and maintain security measures to restrict access to and prevent distribution of the EMT model (e.g. single computer terminal containing the EMT model and restricting access to file areas where the model resides)
- (iv) ensure any publication is only for demonstrating compliance with the specific purpose agreed with **The Company** and shall not include any data directly derived from the EMT model
- (v) not disclose the EMT model
- (vi) destroy all copies of the EMT model and supporting material in a confidentially secure manner after the execution of the specific purpose is complete. Destruction of the EMT model and supporting material shall be confirmed to **The Company** in writing.

PC.A.9.6.2.5 The **User** shall notify **The Company** of any changes to EMT models in accordance with PC.A.1.2. Unless specified otherwise in the **Bilateral Agreement**, EMT models must be submitted:

- (i) at least 3 months prior to date requested for issue of the **Interim Operational Notification**
- (ii) at least 1 month prior to date of issue of a **Limited Operational Notification** for the **Users Plant and Apparatus**.

#### PC.A.9.7 VALIDATION

PC.A.9.7.1 The **User** shall submit evidence that the models have been validated demonstrating that the models under simulation conditions is representative of the **User's Plant and Apparatus** under equivalent conditions. Validation of models before commissioning may be against test results at other comparable sites, Factory Acceptance Tests of comparable equipment, or type test results to show that the responses shown by the models are representative of the **Users Plant and Apparatus**. Results from model validation in accordance internationally recommended standards (for example IEC) where applicable are also acceptable.

PC.A.9.7.2 A User may request agreement from **The Company** on the process for validating the models. In particular, for **Users Plant and Apparatus** where Factory Acceptance Testing is to be carried out details of any additional model validation at this stage should be agreed in a timely manner prior to the testing being carried out. Tests should generally include steady state **Reactive Power** capability, voltage control, **Fault Ride Through** and **Frequency** response.

PC.A.9.7.3 After final compliance testing as required under the **CP** or **ECP**, the **User** shall carry out validation of the model simulation results against measurements from final compliance testing in accordance with CP.A.3 or ECP.A.3, to ensure the model responses are representative of the **Users Plant and Apparatus**.

PC.A.9.7.4 If these tests show the models are not representative of the **User's Plant and Apparatus**, the **User** shall provide updated models, supporting documentation and associated data to ensure the responses shown by the model is representative of the responses shown by **User's Plant and Apparatus** during testing.

- PC.A.9.7.5 In the event **The Company** identifies through lifetime monitoring (OC5) that that the response of the models are not representative of the **User's Plant and Apparatus**, **The Company** shall notify the **User**. The **User** shall provide the revised models, supporting documentation and associated data whose response is representative of the **Users Plant and Apparatus** as soon as reasonably practicable, but in any case no longer than 54 days after notification by **The Company**. In the event of revised models not being made available a **Limited Operational Notification** (as detailed in CP.9 or ECP.9 as applicable) may be issued with appropriate restrictions.
- PC.A.9.7.6 The **User** is responsible for ensuring the models remain representative of the **User's Plant and Apparatus** throughout the operational lifetime of the **User's Plant and Apparatus**. In the event of the **User** modifying hardware/software which affects the control and/or operation of the **Users Plant and Apparatus**, the **User** shall provide **The Company** with updated models, supporting documentation and associated data to enable **The Company** to assess the impact of the modification of the **Users Plant and Apparatus** on the **Total System**. Such changes may require other compliance activity as described in the **CP** or **ECP** as applicable.
- PC.A.9.7.7 The **User** shall demonstrate that the representation of a **User's Plant and Apparatus** and models perform correctly in a sample network model published by **The Company** before being accepted. The **User** should represent the **User's Plant and Apparatus** modelled in accordance with the **Single Line Diagram** and parameters submitted under the **Planning Code** and **DRC** in Schedules 1, 5 or 18 aggregating multiple **Power Park Units** and the collector grid to a single **Power Park Unit** representing a **Power Park Module**.
- PC.A.9.8 RMS MODEL PERFORMANCE SPECIFICATION
- PC.A.9.8.1 The RMS models shall be provided in the format required by **The Company**. **The Company** shall publish on **The Company** website acceptable software versions. **The Company** will act reasonable in determining acceptable software versions or compatible formats. In accordance with good industry practice **The Company** will consult with the industry prior to changing the format required. Prior to the start of model development the **User** may request formal agreement from **The Company** of the software version. The RMS models shall be compatible with Objectives as outlined in Grid Code PC.A.9.1 Additional guidance on RMS model is published on **The Company** website.
- PC.A.9.8.2 GENERAL
- PC.A.9.8.2.1 User RMS models shall interface with the software in a manner that is consistent with the behaviour of standard library models.
- PC.A.9.8.2.1 The models shall use standard library functional blocks representing using standard Laplace block diagram format to the extent practicable.. Where user defined functional blocks have been submitted the **User** must provide **The Company** with the relevant documentation for the model including transfer block diagrams and an explanation of any coding to the satisfaction of **The Company**.
- PC.A.9.8.2.2 The use of any "black boxes" encrypted code or external DLLs is not acceptable. An additional RMS model with these features maybe provided for comparison but for the avoidance of doubt does not meet the requirements of PC.A.9.
- PC.A.9.8.2.3 The **User** shall specify the operating ranges for the model and shall be consistent with the real physical values and the actual performance of the **Plant and Apparatus**. This may include **Reactive Power** limits and allowable voltage ranges with control mode and **Droop** settings configured according to the usual operation. This information shall be provided either on the appropriate per unit base or in physical units.
- PC.A.9.8.2.4 The RMS model must compile without errors. Warnings must be kept to a minimum.
- PC.A.9.8.3 INITIALISATION

- PC.A.9.8.3.1 The RMS model shall be self contained. The combined load-flow and dynamic model shall solve with minimal warnings without the need for manual adjustment or to run external software routines that adjust parameters in either the load-flow case or the dynamic case or both. External software or automation routines to integrate the model are not acceptable.
- PC.A.9.8.3.2 The RMS model shall automatically initialise its parameters from load flow simulations without errors and with minimal warnings , must not result in run time errors and run with minimal warnings , and there must not be any interactions or conflicts with other models. The RMS models initialisation shall be invariant to simulation start time (i.e. not require the simulation to be initialised at a particular time). External software or automation routines to initialise the model are not acceptable.
- PC.A.9.8.3.3 The RMS model is expected to be numerically stable and must adequately represent the expected equipment behaviour over the operational range of the **Plant and Apparatus** at the **Connection Point**. This includes the full load and **Reactive Power** range of the **Plant and Apparatus**, the range of system voltage and **frequency** operating range (described in Grid Code CC.6.1/ECC.6.1), short circuit levels and X/R ratio at the **Connection Point** where it would be in operation. These values maybe requested from **The Company** or the **Distribution Network Owner** during the compliance process. If necessary, the **User** shall provide a supplementary model for specific conditions. All information on the model capabilities shall be addressed in the model documentation provided to **The Company**.
- PC.A.9.8.4 OUTPUT MESSAGES
- PC.A.9.8.4.1 It is not acceptable for the models to crash catastrophically and provide no documentary evidence as to why the simulation failed.
- PC.A.9.8.4.2 RMS models shall allow all appropriate internal variables to be requested for output for the duration of the simulation.
- PC.A.9.8.4.3 In the case where the **User's Plant** trips during simulation, the relevant RMS models shall set the flag that indicates that the **User's Plant** has tripped.
- PC.A.9.8.4.4 For protection events (e.g. crow bar controller operation) the simulation events, including initial detection, operation, and time-out, should be reported to the PowerFactory output window during the simulation.
- PC.A.9.8.5 Integration Time Step
- PC.A.9.8.5.1 The dynamic model must support time domain simulations with a minimum integration step size of 0.01 s.
- PC.A.9.8.5.2 The models must not include algorithms that require use of a particular integration step size (for example the control system model should not fail to solve, or the response be materially different for an integration step size of 0.005 s).
- PC.A.9.8.5.3 Time constants below 0.01 s should only be included if their inclusion is critical to the performance of the dynamic model and should be agreed with **The Company**. In this case, an alternative model may be requested according to PC.A.9.8.3.3, if required.
- PC.A.9.8.5.4 Internal integration algorithms should only be included if their inclusion is critical to meeting the accuracy requirements, and should not materially detract from model simulation speed performance.
- PC.A.9.9 EMT MODEL PERFORMANCE SPECIFICATION

- PC.A.9.9.1 The **User** shall provide EMT models in the format required by **The Company**. **The Company** shall maintain a list of acceptable software versions, and compiler version which shall be published on **The Company** website. **The Company** will act reasonable in determining acceptable software versions or compatible formats. In accordance with good industry practice **The Company** will consult with the industry prior to changing the format required. The EMT models shall be compatible with Objectives as outlined in Grid Code PC.A.9.1 and **The Company** shall also publish on **The Company** website a description of the types of study that **The Company** and **Transmission Licensees** will use the EMT control system models in. Additional guidance on EMT model is also published on **The Company** website.
- PC.A.9.9.2 The EMT models maybe encrypted. The scope, behaviour and performance of all encrypted elements must be documented. Documentation should include behaviour and performance of all encrypted inner and outer loop control functionality such as voltage control, frequency control, protection systems, convertor controls and phase locked loop controllers (PLL). Aspects of the control system may be omitted provided the study objectives published by **The Company** in accordance with PC.A.9.4.2 are met in which case the documentation should explain any functionality not included in the EMT control system model.
- PC.A.9.9.3 The EMT model shall:
- i) have adjustable operational control parameters. For example this would be expected to include setpoints, control drops, operational limits, relay thresholds. The **User** may seek agreement from **The Company** on the list of adjustable parameters prior to submission of the model.
  - ii) be based on plant design and validated against testing of the **Plant and Apparatus** (See Model Validation )
  - iii) include all control systems from outer loop control down to inner and switching functions
  - iv) represent all electrical, mechanical and control features appropriate for the **Plant and Apparatus** including switching algorithms of power convertors applicable to studies described by **The Company**.
  - v) Have all appropriate protection systems modelled for power system transient stability analysis including balanced and unbalanced fault conditions, **Frequency** and voltage disturbances configured to match the site specific installation of the **Plant and Apparatus**. Any protections which relate to multiple disturbances should have an option to be disabled.
  - vi) Allow **Plant and Apparatus** to be scaled where appropriate in accordance with good industry practice. For example representation of multiple **Power Park Units** by a single equivalent unit.
  - vii) Have time steps which must be appropriate for the accurate representation of the switching algorithms used in the **Plant and Apparatus** and compatible with study time steps down to 10us.
  - viii) Be portable between network models which may be any size between a single machine infinite bus power system representation and a full multi node power system network depending on the studies that need to be undertaken.
  - ix) Allow multiple instances within a network and be compatible with other control system models within a network.
  - x) Be capable of self initiation to **User** defined terminal conditions within 4 seconds of the simulation time when connected to an equivalent Thevenin source. In the case of complex models **The Company** may agree a self initiation simulation time within 6 seconds.
  - xi) Warn the **User** by way of an output message when **System** conditions exceed the operational limits of the **Plant and Apparatus** or are not valid for continued operation.
  - xii) Be able to be initialised from a snapshot of network conditions

**APPENDIX B - SINGLE LINE DIAGRAMS**

PC.B.1 The diagrams below show three examples of single line diagrams, showing the detail that should be incorporated in the diagram. The first example is for an **Network Operator** connection, the second for a **Generator** connection, the third for a **Power Park Module** electrically equivalent system.

**Network Operator** Single Line Diagram

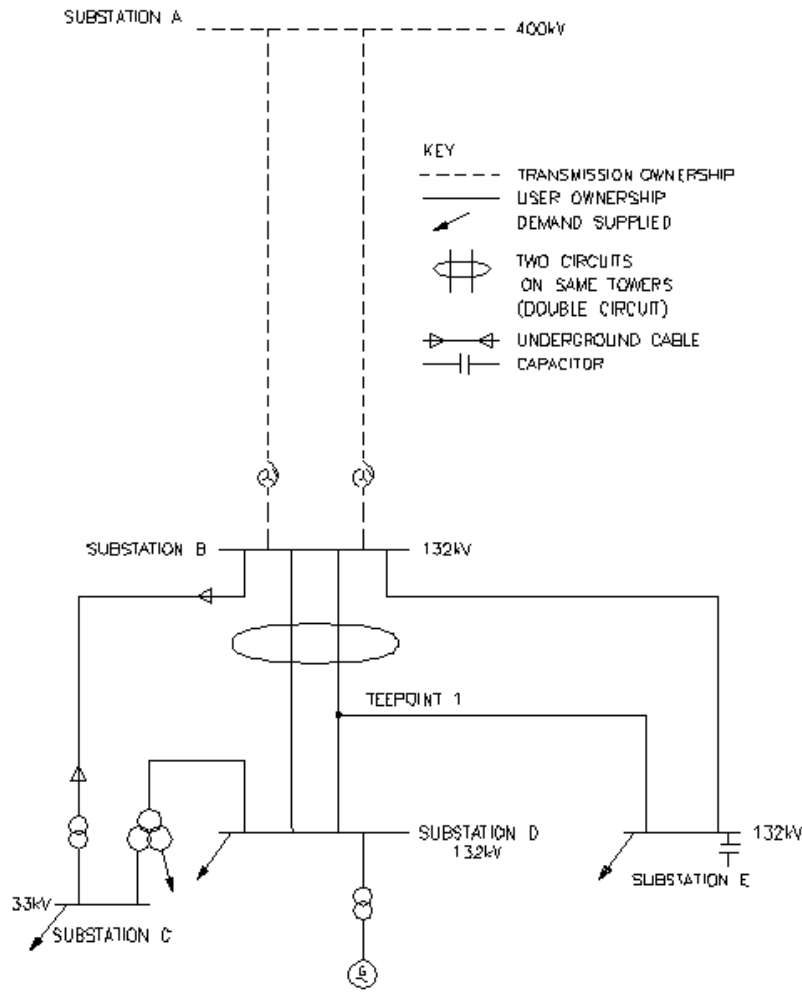

**Commented [BS469]:** Currently we are not showing transmission network beyond SGTs. Will NG provide the diagrams for the dotted network?

OWNER'S COPY  
DO NOT WRITE ON THIS SHEET

41/18826\_1\_1 ISS D 29-07-04

**Generator Single Line Diagram**

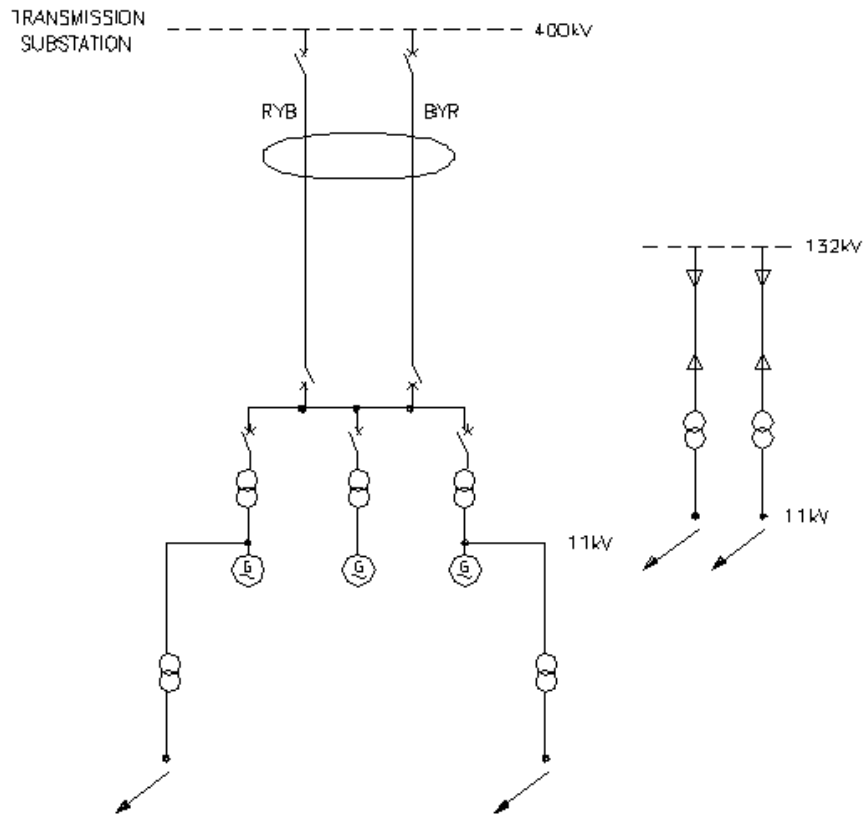

- KEY**
- TRANSMISSION OWNERSHIP
  - USER OWNERSHIP
  - ↙ DEMAND SUPPLIED
  - ⊕ TWO CIRCUITS ON SAME TOWERS (DOUBLE CIRCUIT)
  - ▷◁ UNDERGROUND CABLE

FORWARDED BY  
NET ENERGY CO.  
PERIOD BUREAU

ISS D  
41/19468\_1\_1 29-07-04

**Power Park Module Single Line Diagram**

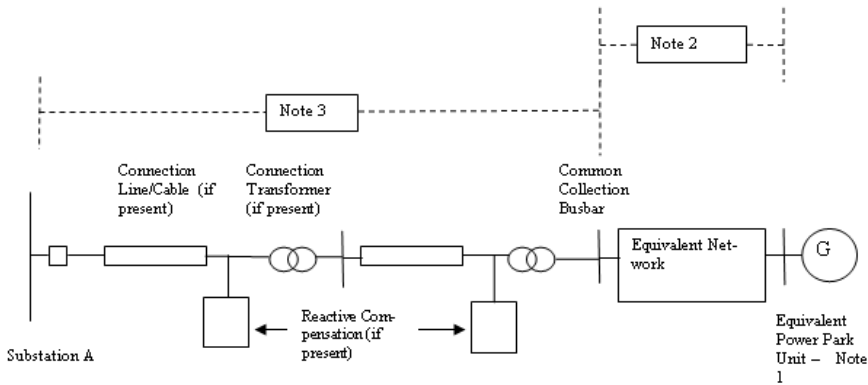

**Notes:**

- (1) The electrically equivalent **Power Park Unit** consists of a number of actual **Power Park Units** of the same type ie. any equipment external to the **Power Park Unit** terminals is considered as part of the equivalent network. **Power Park Units** of different types shall be included in separate electrically equivalent **Power Park Units**. The total number of equivalent **Power Park Units** shall represent all of the actual **Power Park Units** in the **Power Park Module** (which could be a **DC Connected Power Park Module**).
- (2) Separate electrically equivalent networks are required for each different type of electrically equivalent **Power Park Unit**. The electrically equivalent network shall include all equipment between the **Power Park Unit** terminals and the **Common Collection Busbar**.
- (3) All **Plant** and **Apparatus** including the circuit breakers, transformers, lines, cables and reactive compensation plant between the **Common Collection Busbar** and Substation A shall be shown.

**Commented [BS470]:** We typically don't show the details of Generators or Power Park Modules on the single line diagrams as the networks are normally reduced at higher voltage level.



**APPENDIX C - TECHNICAL AND DESIGN CRITERIA**

- PC.C.1 Planning and design of the **SPT** and **SHETL Transmission Systems** is based generally, but not totally, on criteria which evolved from joint consultation among various **Transmission Licensees** responsible for design of the **National Electricity Transmission System**.
- PC.C.2 The above criteria are set down within the standards, memoranda, recommendations and reports and are provided as a guide to system planning. It should be noted that each scheme for reinforcement or modification of the **Transmission System** is individually designed in the light of economic and technical factors associated with the particular system limitations under consideration.
- PC.C.3 The tables below identify the literature referred to above, together with the main topics considered within each document.

**PART 1 – SHETL's TECHNICAL AND DESIGN CRITERIA**

ITEM No.	DOCUMENT	REFERENCE No.
1	National Electricity Transmission System Security and Quality of Supply Standard	Version [ ]
2	System Phasing	TPS 13/4
3	Not used	
4	Voltage fluctuations and the connection of disturbing equipment to transmission systems and distribution networks in the United Kingdom	EREC P28 Issue 2
5	EHV or HV Supplies to Induction Furnaces  Voltage unbalance limits. Harmonic current limits.	ER P16 (Supported by ACE Report No.48)
6	Planning Levels for Harmonic Voltage Distortion and the Connection of Non-Linear Loads to Transmission Systems and Public Electricity Supply Systems in the United Kingdom  Harmonic distortion (waveform). Harmonic voltage distortion. Harmonic current distortion. Stage 1 limits. Stage 2 limits. Stage 3 Limits Addition of Harmonics Short Duration Harmonics Site Measurements	ER G5 (Supported by ACE Report No.73)
7	AC Traction Supplies to British Rail  Type of supply point to railway system. Estimation of traction loads. Nature of traction current. System disturbance estimation. Earthing arrangements.	ER P24

ITEM No.	DOCUMENT	REFERENCE No.
8	Operational Memoranda  Main System operating procedure.  Operational standards of security.  Voltage and reactive control on main system.  System warnings and procedures for instructed load reduction.  Continuous tape recording of system control telephone messages and instructions.  Emergency action in the event of an exceptionally serious breakdown of the main system.	(SOM)  SOM 1  SOM 3  SOM 4  SOM 7  SOM 10  SOM 15
9	Planning Limits for Voltage Unbalance in the United Kingdom.	ER P29

**PART 2 - SPT's TECHNICAL AND DESIGN CRITERIA**

ITEM No.	DOCUMENT	REFERENCE No.
1	National Electricity Transmission System Security and Quality of Supply Standard	Version [ ]
2	System Phasing	TDM 13/10,002 Issue 4
3	Not used	
4	Voltage fluctuations and the connection of disturbing equipment to transmission systems and distribution networks in the United Kingdom	EREC P28 Issue 2
5	EHV or HV Supplies to Induction Furnaces  Voltage Unbalance limits. Harmonic current limits.	ER P16 (Supported by ACE Report No.48)
6	Planning Levels for Harmonic Voltage Distortion and the Connection of Non-Linear Loads to Transmission Systems and Public Electricity Supply Systems in the United Kingdom  Harmonic distortion (waveform). Harmonic voltage distortion. Harmonic current distortion. Stage 1 limits. Stage 2 limits. Stage 3 Limits Addition of Harmonics Short Duration Harmonics Site Measurements	ER G5 (Supported by ACE Report No.73)
7	AC Traction Supplies to British Rail  Type of supply point to railway system. Estimation of traction loads. Nature of traction current. System disturbance estimation. Earthing arrangements.	ER P24

**APPENDIX D - DATA NOT DISCLOSED TO A RELEVANT TRANSMISSION LICENSEE**

PC.D.1 Pursuant to PC.3.4, **The Company** will not disclose to a **Relevant Transmission Licensee** data items specified in the below extract:

PC REFERENCE	DATA DESCRIPTION	UNITS	DATA CATEGORY
PC.A.3.2.2 (f) (i)	<p>(i) For <b>GB Code Users</b></p> <p>The <b>Generator Performance Chart</b> at the <b>Generating Unit</b> stator terminals</p> <p>(ii) For <b>EU Code Users:-</b></p> <p>The <b>Power Generating Module Performance Chart</b>, and <b>Synchronous Generating Unit Performance Chart</b>;</p>		<b>SPD</b>
PC.A.3.2.2 (b)	<b>Output Usable</b> (on a monthly basis)	MW	<b>SPD</b>
PC.A.5.3.2 (d) Option 1 (iii)	<p>GOVERNOR AND ASSOCIATED PRIME MOVER PARAMETERS</p> <p>Option 1</p> <p>BOILER &amp; STEAM TURBINE DATA</p> <p>Boiler time constant (Stored <b>Active Energy</b>)</p> <p>HP turbine response ratio: (Proportion of <b>Primary Response</b> arising from HP turbine)</p> <p>HP turbine response ratio: (Proportion of <b>High Frequency Response</b> arising from HP turbine)</p>	<p>S</p> <p>%</p> <p>%</p>	<p><b>DPD II</b></p> <p><b>DPD II</b></p> <p><b>DPD II</b></p>
Part of PC.A.5.3.2 (d) Option 2 (i)	<p>Option 2</p> <p>All <b>Generating Units</b> (including <b>Synchronous Generating Units</b> forming part of a <b>Synchronous Power Generating Module</b>)</p> <p><b>Governor Deadband</b> or (<b>Frequency Response Deadband</b> and <b>Frequency Response Insensitivity</b>)*</p> <p>- Maximum Setting</p> <p>- Normal Setting</p> <p>- Minimum Setting</p> <p>*(Note <b>GB Generators</b> who are not required to satisfy the requirements of the <b>European Connection Conditions</b> do not need to supply <b>Frequency Response Deadband</b> or <b>Frequency Response Insensitivity</b> data).</p>	<p>±Hz</p> <p>±Hz</p> <p>±Hz</p>	<p><b>DPD II</b></p> <p><b>DPD II</b></p> <p><b>DPD II</b></p>
Part of PC.A.5.3.2 (d) Option 2 (ii)	<b>Steam Units</b>		

PC REFERENCE	DATA DESCRIPTION	UNITS	DATA CATEGORY
	Reheater Time Constant	sec	DPD II
	Boiler Time Constant	sec	DPD II
	HP Power Fraction	%	DPD II
	IP Power Fraction	%	DPD II
Part of PC.A.5.3.2 (d) Option 2 (iii)	<b>Gas Turbine Units</b> Waste Heat Recovery Boiler Time Constant		
Part of PC.A.5.3.2 (e)	UNIT CONTROL OPTIONS		
	Maximum droop	%	DPD II
	Minimum droop	%	DPD II
	Maximum <b>Governor Deadband</b> or (Maximum <b>Frequency Response Deadband</b> and Maximum <b>Frequency Response Insensitivity</b> )*	±Hz	DPD II
	Normal <b>Governor Deadband</b> or (normal <b>Frequency Response Deadband</b> and normal <b>Frequency Response Insensitivity</b> )*	±Hz	DPD II
	Minimum <b>Governor Deadband</b> or (minimum <b>Frequency Response Deadband</b> and minimum <b>Frequency Response Insensitivity</b> )*	±Hz	DPD II
	Maximum Output <b>Governor Deadband</b> or (Maximum Output <b>Frequency Response Deadband</b> and Maximum Output <b>Frequency Response Insensitivity</b> )*	±MW	DPD II
	Normal Output <b>Governor Deadband</b> or (Normal Output <b>Frequency Response Deadband</b> and Normal Output <b>Frequency Response Insensitivity</b> )*	±MW	DPD II
	Minimum Output <b>Governor Deadband</b> or (Minimum Output <b>Frequency Response Deadband</b> and Minimum Output <b>Frequency Response Insensitivity</b> )*	±MW	DPD II
	(Note <b>Generators</b> who are not required to satisfy the requirements of the <b>European Connection Conditions</b> do not need to supply <b>Frequency Response Deadband</b> and <b>Frequency Response Insensitivity</b> data).		
	Frequency settings between which Unit Load Controller droop applies:		
	Maximum	Hz	DPD II
	Normal	Hz	DPD II
	Minimum	Hz	DPD II
	Sustained response normally selected	Yes/No	DPD II
PC.A.3.2.2 (f) (ii)	Performance Chart of a <b>Power Park Modules</b> (including <b>DC Connected Power Park Modules</b> ) at the connection point		SPD

PC REFERENCE	DATA DESCRIPTION	UNITS	DATA CATEGORY
PC.A.3.2.2 (b)	<b>Output Usable</b> (on a monthly basis)	MW	<b>SPD</b>
PC.A.3.2.2 (e) and (j)	<b>DC CONVERTER STATION AND HVDC SYSTEM DATA</b>  <b>ACTIVE POWER TRANSFER CAPABILITY</b> (PC.A.3.2.2)  Import MW available in excess of <b>Registered Import Capacity</b> .  Time duration for which MW in excess of <b>Registered Import Capacity</b> is available  Export MW available in excess of <b>Registered Capacity</b> .  Time duration for which MW in excess of <b>Registered Capacity</b> is available	MW  Min  MW  Min	<b>SPD</b>  <b>SPD</b>  <b>SPD</b>  <b>SPD</b>
Part of PC.A.5.4.3.3	<b>LOADING PARAMETERS</b>  MW Export  Nominal loading rate  Maximum (emergency) loading rate  MW Import  Nominal loading rate  Maximum (emergency) loading rate	MW  MW/s  MW/s  MW/s  MW/s  MW/s	<b>SPD</b>  <b>DPD I</b>  <b>DPD I</b>  <b>DPD I</b>  <b>DPD I</b>

**APPENDIX E - OFFSHORE TRANSMISSION SYSTEM AND OTSDUW PLANT AND APPARATUS  
TECHNICAL AND DESIGN CRITERIA**

- PC.E.1 In the absence of any relevant **Electrical Standards, Offshore Transmission Licensees and Generators** undertaking **OTSDUW** are required to ensure that all equipment used in the construction of their network is:
- (i) Fully compliant and suitably designed to any relevant **Technical Specification**;
  - (ii) Suitable for use and operation in an **Offshore** environment, where such parts of the **Offshore Transmission System** and **OTSDUW Plant and Apparatus** are located in **Offshore Waters** and are not installed in an area that is protected from that **Offshore** environment, and
  - (iii) Compatible with any relevant **Electrical Standards** or **Technical Specifications** at the **Offshore Grid Entry Point** and **Interface Point**.

PC.E.2 The table below identifies the technical and design criteria that will be used in the design and development of an **Offshore Transmission System** and **OTSDUW Plant and Apparatus**.

ITEM No.	DOCUMENT	REFERENCE No.
1	National Electricity Transmission System Security and Quality of Supply Standard	Version [ ]
2*	Voltage fluctuations and the connection of disturbing equipment to transmission systems and distribution networks in the United Kingdom	EREC P28 Issue 2
3*	Planning Levels for Harmonic Voltage Distortion and the Connection of Non-Linear Loads to Transmission Systems and Public Electricity Supply Systems in the United Kingdom	ER G5
4*	Planning Limits for Voltage Unbalance in the United Kingdom	ER P29

\* Note:- Items 2, 3 and 4 above shall only apply at the **Interface Point**.

**APPENDIX F - OTSDUW DATA AND INFORMATION AND OTSDUW NETWORK DATA AND INFORMATION**

- PC.F.1 Introduction
- PC.F.1.1 Appendix F specifies data requirements to be submitted to **The Company** by **Users** and **Users** by **The Company** in respect of **OTSDUW**.
- PC.F.1.2 Such **User** submissions shall be in accordance with the **OTSDUW Development and Data Timetable** in a **Construction Agreement**.
- PC.F.1.3 Such submissions shall be issued to **The Company** with the offer of a **CUSC Contract** in the case of the data in Part 1 and otherwise in accordance with the **OTSDUW Development and Data Timetable** in a **Construction Agreement**.
- PC.F.2. OTSDUW Network Data and Information
- PC.F.2.1 With the offer of a **CUSC Contract** under the **OTSDUW Arrangements** **The Company** shall provide:
- (a) the site specific technical design and operational criteria for the **Connection Site**;
  - (b) the site specific technical design and operational criteria for the **Interface Point**, and
  - (c) details of **The Company's** preliminary identification and consideration of the options available for the **Interface Point** in the context of the **User's** application for connection or modification, the preliminary costs used by **The Company** in assessing such options and the **Offshore Works Assumptions** including the assumed **Interface Point** identified during these preliminary considerations.
- PC.F.2.2 In accordance with the **OTSDUW Development and Data Timetable** in a **Construction Agreement** **The Company** shall provide the following information and data to a **User**:
- (a) equivalent of the fault infeed or fault level ratings at the Interface Point (as identified in the **Offshore Works Assumptions**)
  - (b) notification of numbering and nomenclature of the **HV Apparatus** comprised in the **OTSDUW**;
    - (i) past or present physical properties, including both actual and designed physical properties, of **Plant** and **Apparatus** forming part of the **National Electricity Transmission System** at the Interface Point at which the **OTSUA** will be connected to the extent it is required for the design and construction of the **OTSDUW**, including but not limited to:
      - (ii) the voltage of any part of such **Plant** and **Apparatus**;
      - (iii) the electrical current flowing in or over such **Plant** and **Apparatus**;
      - (iv) the configuration of any part of such **Plant** and **Apparatus**
      - (v) the temperature of any part of such **Plant** and **Apparatus**;
      - (vi) the pressure of any fluid forming part of such **Plant** and **Apparatus**
      - (vii) the electromagnetic properties of such **Plant** and **Apparatus**; and
      - (viii) the technical specifications, settings or operation of any **Protection Systems** forming part of such **Plant** and **Apparatus**.
  - (c) information necessary to enable the **User** to harmonise the **OTSDUW** with construction works elsewhere on the **National Electricity Transmission System** that could affect the **OTSDUW**;
  - (d) information related to the current or future configuration of any circuits of the **Onshore Transmission System** with which the **OTSUA** are to connect;



(e) any changes which are planned on the **National Electricity Transmission System** in the current or following six **Financial Years** and which will materially affect the planning or development of the **OTSDUW**.

PC.F.2.3 At the **Users** reasonable request, additional information and data in respect of the **National Electricity Transmission System** shall be provided.

PC.F.2.4 OTSDUW Data And Information

PC.F.2.4.1 In accordance with the **OTSDUW Development and Data Timetable** in a **Construction Agreement**, the **User** shall provide to **The Company**, the following information and data relating to the **OTSDUW Plant and Apparatus** in accordance with Appendix A of the **Planning Code**.

**APPENDIX G – NETWORK OPERATOR AND THE COMPANY PLANNING DATA EXCHANGE**

**PC.G.1 Data to be included in the Solved PSM**

**PC.G.1.1 The Solved PSM:**

- a. Shall include **Structural, Situation, and Solution Data** relating to all relevant equipment within the scope of the **Network Operator Subtransmission PSM or The Company NETS PSM** as set out in PC.9.4 and PC.10.4, respectively.
- b. Shall conform to the data exchange definitions and implementation requirements described in PC.G.4.
- c. May include additional data if supported by the data exchange definitions.

**PC.G.1.2 PSM data shall meet the following general requirements regarding Structural Data:**

- i. Define the connectivity of all relevant equipment.
- ii. Have identifiers which are unique and remain consistent throughout the life of the data as required in PC.3.1.1.5.
- iii. Have name and description sufficient to provide human readability.

**PC.G.1.3 Equipment**

**PC.G.1.3.1 For all equipment the following data shall be included in the PSM:**

- a. Structural Data
  - i. The line, substation or substation voltage level, as applicable, of which it is a part

**PC.G.1.3.1 For each busbar the following data shall be included in the PSM:**

- a. Structural Data
  - i. Node by which it is represented
- b. Solution Data:
  - i. Voltage magnitude and angle if energised

**PC.G.1.3.1.1 For each busbar designated as a PSM Interface Node the following data shall additionally be included in the PSM:**

- a. Solution Data (short circuit):
  - i. Fault kind (single- or 3-phase)
  - ii. Steady state current
  - iii. Maximum steady state current
  - iv. Minimum steady state current
  - v. Peak current
  - vi. Decaying component current
  - vii. Initial symmetrical current
  - viii. Initial symmetrical power
  - ix. Symmetrical breaking current
  - x. Symmetrical breaking current angle

**PC.G.1.3.2 For each circuit breaker, and for each switch required to facilitate system reconfiguration (breaker, disconnect, disconnecting circuit breaker, ground disconnect, DC switch, load break switch or switch), the following data shall be included in the PSM:**

- a. Structural Data
  - i. Rated voltage
  - ii. Normal operating status
  - iii. Rated RMS continuous current
  - iv. Indication if the breaker/switch shall be preserved in topology processing irrespective of the switching status
  - v. Rated 3-phase RMS short-circuit withstand current of breaker/switch and surrounding substation infrastructure
  - vi. Rated 1-phase RMS short-circuit withstand current of breaker/switch and surrounding substation infrastructure
  - vii. Rated 3-phase short-circuit peak withstand current of breaker/switch and surrounding substation infrastructure
  - viii. Rated 1-phase short-circuit peak withstand current of breaker/switch and surrounding substation infrastructure
  - ix. Rated duration of short circuit withstand of breaker/switch and surrounding substation infrastructure
  - x. Rated RMS continuous current of breaker/switch and surrounding substation infrastructure

**Commented [BS471]:** Do we know if the following requirements are available in CIM standard? Have we got any gap analysis done against the CIM?

**Commented [BS472R471]:** What validation or conformity tests should be in place for a successful CIM exchange between NESO and DNOs?

**Commented [AC473]:** Comments provided on standalone document that was circulated 23 Aug 2024

**Commented [VG474]:** Have a name

**Commented [VG475]:** Align indent with i. above

**Commented [VG476]:** Is it clear what a busbar voltage magnitude is?

**Commented [VG477]:** energised

- xi. Additionally, for every circuit breaker (breaker, disconnecting circuit breaker, or load break switch):
  - i. DC time constant applied at testing of asymmetrical breaking abilities.
  - ii. Break time.
  - iii. Rated 3-phase peak short-circuit making current.
  - iv. Rated 1-phase peak short-circuit making current.
  - v. Rated 3-phase RMS short-circuit breaking current.
  - vi. Rated 1-phase RMS short-circuit breaking current.

- b. Situation Data
  - i. In-service status.
  - ii. Operational position and information if the switching device is locked.
- c. Solution Data
  - i. Operational position.

PC.G.1.3.3 For each transformer (including step-up transformers, auto transformers, and phase shifting transformers) the following data shall be included in the PSM:

- a. Structural Data
  - i. For the transformer itself:
    - i. Highest operating current and voltage before short circuit
  - ii. For each transformer winding:
    - i. Rated apparent power
    - ii. Rated voltage
    - iii. Voltage ratio
    - iv. Positive sequence reactance and resistance
    - v. Zero sequence reactance and resistance
    - vi. Positive sequence susceptance and conductance
    - vii. Zero sequence susceptance and conductance
    - viii. Connection type, for instance type D, Y, Yn, including any tertiary winding.
    - ix. Vector group
    - x. Grounding reactance and resistance
    - xi. Earthing method (direct, resistance, reactance, through earthing transformer or none)
    - xii. Positive sequence reactance and resistance at minimum and maximum tap
    - xiii. Normal seasonal operational limits
  - iii. For the tap changer:
    - i. Tap changer steps information (high step, low step, neutral step)
    - ii. Tap changer on-load change capability
    - iii. Type of phase tap changer: symmetrical, asymmetrical described in a linear, non-linear, or tabular way
    - iv. Tap changer control mode and regulating range
    - v. Impedance information per tap step, if applicable
    - vi. Operational limit per tap step, if applicable

- b. Situation Data
  - i. For the transformer itself:
    - i. In-service status
  - ii. For each winding:
    - i. Operating limits to be used as power flow solution violation limits
  - iii. For the tap changer:
    - i. Tap changer regulating status
    - ii. Tap changer regulating quantity target value
    - iii. Tap changer regulating deadband
    - iv. Tap changer step

- c. Solution Data
  - i. For the transformer itself:
    - i. In-service status
  - ii. For the tap changer:
    - i. Tap changer step

PC.G.1.3.4 For each circuit the following data shall be included in the PSM:

- a. Structural Data
  - i. Data required for power flow and short circuit calculations: positive, zero and mutual coupling sequence resistance, reactance, susceptance and conductance
  - ii. Operating voltage
  - iii. Length of circuit
  - iv. Max permitted temperature at the end of the short circuit
  - v. Overhead/underground indication
  - vi. Overhead line phasing arrangements on towers
  - vii. Normal seasonal operating limits

- b. Situation Data
  - i. In-service status
  - ii. Operating limits to be used as power flow solution violation limits

- c. Solution Data
  - i. Calculated active and reactive power flows for the circuit

PC.G.1.3.5 For each compensating equipment (including linear and non-linear shunts, series compensators, and static var compensators), the following data shall be included in the PSM:

- a. Structural Data
  - i. Operating type of compensation equipment (switched equipment with automated module activation or fixed equipment that can only be operated manually)
  - ii. For shunt compensators, the compensation type (for instance, R-L, R-L-C, C, R-L-C)
  - iii. Nominal voltage
  - iv. For controllable compensating equipment, the regulating mode and regulating range
  - v. For discrete shunt compensating equipment
    - i. Positive sequence conductance and susceptance per section
    - ii. Zero sequence conductance and susceptance per section
    - iii. Nominal compensation power per section
    - iv. Number of maximum sections
  - vi. For series compensating equipment
    - i. Positive sequence reactance and resistance
    - ii. Zero sequence reactance and resistance
    - iii. Rated current and voltage threshold, if varistor is present
  - vii. For continuous compensating equipment, for instance static Var compensators
    - i. Nominal compensation range
    - ii. Capacitive and inductive rating
    - iii. Slope characteristics slope that defines how the reactive power output changes in proportion to the difference between the regulated bus voltage and the voltage setpoint
    - iv. Positive and zero sequence reactance
    - v. Positive and zero sequence resistance

- b. Situation Data
  - i. In-service status
  - ii. Section or initial compensation according to the type of compensating equipment
  - iii. Regulating status
  - iv. Regulating quantity target value

- c. Solution Data
  - i. In-service status
  - ii. For discrete compensating equipment, the active section

PC.G.1.3.6 For each HVDC System, the following data shall be included in the PSM:

- a. Structural Data
  - i. HVDC system is reduced to an element that is capable to provide information on the power output of the HVDC system and voltage regulation capabilities, if applicable
  - ii.
- b. Situation Data
  - i. In-service status

- ii. Active power
- iii. Reactive power

c. Solution Data

- i. In-service status
- ii. Regulating status, if applicable
- iii. Regulating quantity target value, if applicable

d. Specific requirements to related to representation in **The Company NETS PSM**

- i. For HVDC systems internal to the NETS losses need to be accounted for and defined in the PSM Scenario document.

PC.G.1.4 Generation and Storage

PC.G.1.4.1 For each **Synchronous Power Generating Module** (synchronous generator) which is not a **Synchronous Electricity Storage Module**, the following data shall be included in the **PSM**:

a. Structural Data

- i. Nominal apparent power
- ii. Nominal active power
- iii. Nominal terminal voltage
- iv. Nominal power factor
- v. Rotor type by construction
- vi. Rotor type for the purpose of short circuit calculation in accordance with EREC G74
- vii. Active and reactive power limits at nominal voltage
- viii. Reactive capability curve
- ix. Direct axis reactances (saturated and unsaturated)
  - i. Subtransient reactance ( $X_d''$ )
  - ii. Transient reactance ( $X_d'$ )
  - iii. Synchronous reactance ( $X_d$ )
- x. Direct axis time constants (saturated and unsaturated)
  - i. Subtransient time constants ( $T_d''$ )
  - ii. Transient time constant ( $T_d'$ )
- xi. Quadrature axis reactances (saturated and unsaturated)
  - i. Subtransient reactance ( $X_q''$ )
  - ii. Transient reactance ( $X_q'$ )
  - iii. Synchronous reactance ( $X_q$ )
- xii. Quadrature time constants (saturated and unsaturated)
  - i. Subtransient time constants ( $T_q''$ )
  - ii. Transient time constant ( $T_q'$ )
- xiii. Zero sequence reactance and resistance
- xiv. Negative sequence reactance and resistance
- xv. Stator resistance
- xvi. Inertia constant (H)
- xvii. Primary **Energy Source** (from the list given in PC.G.8.1)
- xviii. Regulating mode and regulating range
- xix. Earthing stat point reactance and resistance, if applicable

b. Situation Data

- i. In-service status
- ii. Active and reactive power
- iii. Regulating status
- iv. Regulating quantity target value

c. Solution Data

- i. In-service status
- ii. Calculated active and reactive power output

d. Specific requirements related to representation in the **Network Operator Subtransmission PSM**

- i. The detail specified above is required only for generation connected to the **Subtransmission System**. Generation connected at a voltage below that of the **Subtransmission System** shall be represented as aggregated generation equivalents, grouped by **Aggregated Energy Source**. The following data shall be included in the **PSM** for such equivalents:

1. Structural Data

- a. Nominal apparent power of the aggregation
- b. Nominal active power of the aggregation
- c. Aggregate fault current
- d. X/R ratio of the aggregation
- e. Dominant type of control mode (voltage, power factor or reactive)
- f. Aggregated Energy Source (from the list given in PC.G.8.2)

2. Situation Data

- a. In-service status
- b. Active and reactive power
- c. Regulating status
- d. Regulating quantity target value

3. Solution Data

- a. In-service status
- b. Calculated active and reactive power output

PC.G.1.4.2 For each For each **Power Park Module**, which is not a **Non-Synchronous Electricity Storage Module**, and which is comprised of **Synchronous Generating Units** or **Offshore Power Park Strings** none of which are connected through power electronic conversion technology (i.e., an asynchronous wind generator), the following data shall be included in the **PSM**:

a. Structural Data

- i. Nominal apparent power
- ii. Nominal active power
- iii. Nominal mechanical power
- iv. Nominal terminal voltage
- v. Nominal speed
- vi. Nominal frequency
- vii. Nominal power factor
- viii. Pole pair number
- ix. Locked r/x rotor ratio
- x. Nominal efficiency
- xi. Ratio of locked-rotor current to the rated current of the motor
- xii. Information if it is converter fed drive and reversable capability
- xiii. Primary Energy Source (from the list given in PC.G.8.1)
- xiv. Regulating mode and regulating range

b. Situation Data

- i. In-service status
- ii. Active and reactive power
- iii. Regulating status
- iv. Regulating quantity target value

c. Solution Data

- i. In-service status
- ii. Calculated active and reactive power output

d. Specific requirements related to representation in the Network Operator Subtransmission PSM

i. The detail specified above is required only for generation connected to the Subtransmission System. Generation connected at a voltage below that of the Subtransmission System is represented as aggregated generation equivalents, grouped by Aggregated Energy Source. The following data shall be included in the PSM for such equivalents:

1. Structural Data

- a. Nominal apparent power of the aggregation
- b. Nominal active power of the aggregation
- c. Aggregate fault current
- d. X/R ratio of the aggregation
- e. Dominant type of control mode (voltage, power factor or reactive)
- f. Aggregated Energy Source (from the list given in PC.G.8.2)

2. Situation Data

- a. In-service status
- b. Active and reactive power
- c. Regulating status
- d. Regulating quantity target value

3. Solution Data

- a. In-service status
- b. Calculated active and reactive power output

PC.G.1.4.3 For each **Power Park Module**, which is not a **Non-Synchronous Electricity Storage Module**, and which is comprised of **Non-Synchronous Generating Units** or **Offshore Power Park Strings** which are all connected through power electronic conversion technology (converter-based generation such as wind or chemical), the following data shall be included in the **PSM**:

a. Structural Data

- i. Nominal apparent power
- ii. Nominal active power
- iii. Nominal terminal voltage
- iv. Primary Energy Source (from the list given in PC.G.8.1)
- v. Regulating mode and regulating range

b. Situation Data

- i. In-service status
- ii. Active and reactive power
- iii. Regulating status
- iv. Regulating quantity target value

c. Solution Data

- i. In-service status
- ii. Calculated active and reactive power output

d. Specific requirements related to representation in the Network Operator Subtransmission PSM

i. The detail specified above is required only for generation connected to the Subtransmission System. Generation connected at a voltage below that of the Subtransmission System is represented as aggregated generation equivalents, grouped by Aggregated Energy Source. The following data shall be included in the PSM for such equivalents:

1. Structural Data

- a. Nominal apparent power of the aggregation
- b. Nominal active power of the aggregation
- c. Aggregate fault current
- d. aggregate X/R ratio
- e. Dominant type of control mode (voltage, power factor or reactive)
- f. Aggregated Energy Source (from the list given in PC.G.8.2)

2. Situation Data

- a. In-service status
- b. Active and reactive power
- c. Regulating status
- d. Regulating quantity target value

3. Solution Data

- a. In-service status
- b. Calculated active and reactive power output

PC.G.1.4.4 For each **Synchronous Electricity Storage Module** (compressed air, flywheel, or pumped storage) the following data shall be included in the **PSM**:

a. Structural Data

- i. Nominal energy capability
- ii. Nominal apparent power when supplying
- iii. Nominal apparent power when consuming
- iv. Nominal terminal voltage
- v. Primary Energy Source (from the list given in PC.G.8.1)
- vi. Regulating mode and regulating range
- vii. Minimum and maximum active and reactive power
- viii.

- b. Situation Data
  - i. In-service status
  - ii. Stored energy
  - iii. Storage status
  - iv. Active and reactive power
  - v. Regulating status
  - vi. Regulating quantity target value
- c. Solution Data
  - i. In-service status
  - ii. Calculated active and reactive power output
- d. Specific requirements related to representation in the **Network Operator Subtransmission PSM**
  - i. The detail specified above is required only for storage connected to the **Subtransmission System**. Storage connected at a voltage below that of the **Subtransmission System** is represented as aggregated storage equivalents, grouped by **Aggregated Energy Source**. The following data shall be included in the **PSM** for such equivalents:
    - 1. Structural Data
      - a. Nominal energy capability of the aggregation
      - b. Nominal apparent power of the aggregation when supplying
      - c. Nominal apparent power of the aggregation when consuming
      - d. Equivalent fault current
      - e. X/R ratio of the aggregation
      - f. Dominant type of control mode (voltage, power factor or reactive)
      - g. **Aggregated Energy Source** (from the list given in PC.G.8.2)
    - 2. Situation Data
      - a. In-service status
      - b. Stored energy
      - c. Storage status
      - d. Active and reactive power
      - e. Regulating status
      - f. Regulating quantity target value
    - 3. Solution Data
      - a. In-service status
      - b. Calculated active and reactive power output

PC.G.1.4.5 For each **Non-Synchronous Electricity Storage Module** (battery) the following data shall be included in the **PSM**:

- a. Structural Data
  - i. Nominal energy capability
  - ii. Nominal apparent power when supplying
  - iii. Nominal apparent power when consuming
  - iv. Nominal terminal voltage
  - v. Primary **Energy Source** (from the list given in PC.G.8.1)
  - vi. Regulating mode and regulating range
  - vii. Minimum and maximum active and reactive power
- b. Situation Data
  - i. In-service status
  - ii. Stored energy
  - iii. Storage status
  - iv. Active and reactive power
  - v. Regulating status
  - vi. Regulating quantity target value
- c. Solution Data
  - i. In-service status
  - ii. Calculated active and reactive power output



d. Specific requirements related to representation in the **Network Operator Subtransmission PSM**

i. The detail specified above is required only for storage connected to the **Subtransmission System**. Storage connected at a voltage below that of the **Subtransmission System** is represented as aggregated storage equivalents, grouped by **Aggregated Energy Source**. The following data shall be included in the **PSM** for such equivalents:

1. Structural Data
  - a. Nominal energy capability of the aggregation
  - b. Nominal apparent power of the aggregation when supplying
  - c. Nominal apparent power of the aggregation when consuming
  - d. equivalent fault current
  - e. equivalent X/R ratio
  - f. dominant type of control mode (voltage, power factor or reactive)
  - g. **Aggregated Energy Source** (from the list given in PC.G.8.2)
2. Situation Data
  - a. In-service status
  - b. Stored energy
  - c. Storage status
  - d. Active and reactive power
  - e. Regulating status
  - f. Regulating quantity target value
3. Solution Data
  - a. In-service status
  - b. Calculated active and reactive power output

PC.G.1.4.6 For each substation where a **Power-Generating Module** connects to the **NETS** or the **Subtransmission System**, the equipment providing that connection, including the **Station Transformer** data and the auxiliary load it serves, shall be included in the **PSM**. The following data shall be included for the auxiliary load:

- a. Structural Data
  - i. Subtransient short-circuit current maximum and minimum level
  - ii. Transient short-circuit current maximum and minimum level
  - iii. X" to R maximum and minimum ratios
  - iv. Indication of whether the load is scalable (conform type) or not (non-conform type)
  - v. Load response components i.e. constant power, constant impedance, constant current components
- b. Situation Data
  - i. In-service status
  - ii. Active and reactive power
- c. Solution Data
  - i. In-service status
  - ii. Calculated active and reactive power output

PC.G.1.5 Load

PC.G.1.5.1 For each load the following data shall be included in the **PSM**:

- a. Structural Data
  - i. Declared supply capacity
  - ii. Subtransient short-circuit current maximum and minimum level
  - iii. Transient short-circuit current maximum and minimum level
  - iv. X" to R maximum and minimum ratios
  - v. Indication of whether the load is scalable (conform type) or not (non-conform type)
  - vi. Load response components i.e. constant power, constant impedance, constant current components
- b. Situation Data
  - i. In-service status

- ii. Active and reactive power
- c. Solution Data
  - i. In-service status
  - ii. Calculated active and reactive power output
- d. Specific requirements related to representation in the **Network Operator Subtransmission PSM**
  - i. The detail specified above is required only for load connected to the **Subtransmission System**. All load connected at a voltage below that of the **Subtransmission System** shall be represented as aggregated load equivalents. The following data shall be included in the **PSM** for such equivalents.
    - 1. Structural Data
      - a. Subtransient short-circuit current maximum and minimum level
      - b. Transient short-circuit current maximum and minimum level
      - c. X" to R maximum and minimum ratios
      - d. Information is the load is scalable (conform type) or not (non-conform type)
      - e. Load response components (i.e., constant power, constant impedance, constant current components)
    - 2. Situation Data
      - a. In-service status
      - b. Active and reactive power
    - 3. Solution Data
      - a. In-service status
      - b. Calculated active and reactive power output

PC.G.1.6 Diagram Layout

PC.G.1.6.1 For each of the following types of diagrams, **Diagram Layout Data** shall be included in the **PSM**. The **Diagram Layout Data** shall define the arrangement of the listed **Structural** and/or **Situation Data** on the diagram:

- a. A **PSM** geo-spatial overview diagram containing references to **Structural Data** representing:
  - i. All **NETS** and **GSP** substations in the **PSM**:
  - ii. Lines connecting the above substations:
  - iii. Names of the substations and lines
  - iv. Voltage levels of lines.
- b. A schematic diagram for each substation in the **PSM** containing references to:
  - i. **Structural Data** representing:
    - 1. All equipment (e.g., lines, transformers, switches, busses, compensation equipment), load, and generation/storage, both AC and DC, in the substation;
    - 2. Connectivity of equipment, load and generation/storage;
    - 3. Normal positions of switches and taps
    - 4. Voltage levels of busses.
  - ii. **Situation Data** representing:
    - 1. Starting positions of switches and taps.
- c. Additional diagrams to aid understanding, as appropriate. For example:
  - i. In the case of **Network Operator PSMs**, a schematic diagram for the territory served by each **Connection Point** in the **PSM** containing references to **Structural Data** representing:
    - 1. All substations in the territory;
    - 2. Lines connecting the substations, including indication of circuits which share towers;
    - 3. Busses, transformers, and bus coupling switch devices at each substation;
    - 4. Names of substations, lines and equipment as appropriate
    - 5. Voltage levels of busses.

Commented [VG478]: Structural Data

Commented [BS479]: New requirement. Currently we only provide SLDs. Need work to update Our models

ii. In the case of **The Company**, schematic diagrams for voltage levels of geographic territories containing references to **Structural Data** representing:

1. All substations in the voltage level or territory;
2. Lines connecting the substations, including indication of circuits which share towers;
3. Busses, transformers, and bus coupling switch devices at each substation;
4. Names of substations, lines and equipment as appropriate;
5. Voltage levels of busses.

PC.G.2 Additional Data Not Included in The **Solved PSM**

PC.G.2.1 Several sections of the Planning Code, among them PC.9.3.1 and PC.10.3.1, anticipate the need for the exchange of **PSM**-related data which is not yet supported by the data exchange standards specified in PC.G.4. Several types of such data are described below.

PC.G.2.2 Full Technical **HVDC System Models**

PC.G.2.2.1 Due to the complexity of **HVDC** modelling, **The Company** will model **HVDC** system connection points using a simplistic method. This will comprise of either:

- (a) A single Generation connection for **HVDC** systems that connect the **NETS** and to **EU Grid Supply Point**;
- (b) A single Generation connection for **HVDC** systems that connect the **NETS** to an **OFTO** network which provides the connection of large **Offshore Power Parks**;
- (c) For **HVDC** systems which are wholly connected the **NETS** and have only two connection points. Both these points will be represented by a simple generation but with additional information around system loss allowance listed in the **PSM Scenario Document**
- (d) For **HVDC** systems which are wholly connected the **NETS** and have more than two connection points.
  - (i) Those connection points which are located on the part of the mainland GB part of the **NETS** these points will be represented by a simple generation but with additional information around system loss allowance listed in the **PSM Scenario Document**.
  - (ii) Those connection points which are located outside the mainland GB part of the **NETS** these points will be represented by a simple generation but with additional information around system loss allowance listed in the **PSM Scenario Document**.

PC.G.2.2.2 **The Company** will consider any request from a **Network Operator** for full **HVDC** system model connected to the **NETS**. **The Company** will, where possible, use the data exchange profile standard specified in G.4.1.1 to make this **HVDC** network data available. A **PSM Scenario Document** will be provided with this model to assist the **Network Operator** in utilizing this data.

PC.G.2.2.3 Should **The Company** be unable to facilitate a **Network Operator's** request an alternative method to provide data will be agreed.

PC.G.2.2.4 The exchange of models representing multi-ended **HVDC** system(s) by **The Company** shall be agreed with the relevant **Network Operator(s)**. The agreed method for exchanging this data, which will be outside of the **NETS Solved PSM**, but form part of the **NETS**. At such time as the **GB CIM Governance** updated the **GB CIM** profile, to enable this data to be exchanged as part of the **NETS Solved PSM**.

PC.G.2.3 Demand and Active Energy Data

PC.G.2.3.1 Introduction

- Commented [AC480]: ...including..
- Commented [AC481]: ...standard.... (singular)
- Commented [AC482]: ...of modelling HVDC systems, ....
- Commented [AC483]: ...systems at **Connection Points** using a....
- Commented [AC484]: ...single generator connection....
- Commented [AC485]: ...HVDC Systems....
- Commented [AC486]: ...NETS to an EU.....
- Commented [AC487]: semicolon
- Commented [AC488]: ...single generator connection....
- Commented [AC489]: ..HVDC Systems....
- Commented [VG490]: **Offshore Transmission System**
- Commented [AC491]: ...to an **Offshore Transmission System** which...
- Commented [VG492]: Delete the word 'large'
- Commented [AC493]: ...connection to one or more **Offshore Power Park Modules**;
- Commented [AC494]: There are some words missing here:  
For HVDC systems which are wholly connected the **NETS** and have only two connection points, as a simple generator at each connection point but with additional information around system loss allowance listed in the **PSM Scenario Document**; or
- Commented [AC495]: ..HVDC Systems....
- Commented [VG496]: Does this mean >2 or 2 or more?
- Commented [AC497]: ..Connection Points:
- Commented [AC498]: ..Connection Points...
- Commented [AC499]: Does this mean 'onshore'?
- Commented [AC500]: ...simple (or single?) generator but...
- Commented [AC501]: ...Document; or
- Commented [AC502]: ..Connection Points.....
- Commented [AC503]: bold
- Commented [AC504]: ...simple (or single?) generator but...
- Commented [AC505]: bold
- Commented [AC506]: I don't really follow this - does it mean:  
**The Company** will consider any request from a **Network Operator** for full model of a **HVDC System** where it is connected to the **NETS**.
- Commented [AC507]: PC.G.4.1.1
- Commented [AC508]: ...such HVDC System model available...
- Commented [AC509]: ...with such a model....
- Commented [AC510]: ...utilising this....
- Commented [AC511]: ...request, an alternative...
- Commented [AC512]: ..System(s)..
- Commented [AC513]: unbold
- Commented [AC514]: How can data form part of the **NETS**?
- Commented [VG515]: **CIM**
- Commented [AC516]: ...as the **GB CIM Governance Group** update the ....
- Commented [VG517]: Unbold - GB isn't a defined term
- Commented [AC518]: Not defined term
- Commented [AC519]: Some words missing from this ...

PC.G.2.3.1.1 Each Network Operator directly connected to the National Electricity Transmission System with Demand shall provide The Company with the relevant data for:

PC.G.2.3.1.2 Control of Demand or Reduction of Pumping Load Offered as Reserve

- Magnitude of Demand or pumping load or Electricity Storage Module charging load which is tripped MW
- System Frequency at which tripping is initiated Hz
- Time duration of System Frequency below trip setting for tripping to be initiated S
- Time delay from trip initiation to tripping Sd

PC.G.2.4 General Demand Data

PC.G.2.4.1 The following information is infrequently required and should be supplied (wherever possible) when requested by The Company:

- (a) details of any individual loads (including (as applicable) the load behaviour of an Electricity Storage Module when operating in a mode analogous to demand) which have characteristics significantly different from the typical range of Domestic, Commercial, Electricity Storage or Industrial loads supplied;
- (b) the sensitivity of the Demand (Active and Reactive Power) to variations in voltage and Frequency on the National Electricity Transmission System at the time of the peak Demand (Active Power). The sensitivity factors quoted for the Demand (Reactive Power) should relate to that given under PC.G.2.5.1;
- (c) details of any traction loads, e.g. connection phase pairs and continuous load variation with time;
- (d) the average and maximum phase unbalance, in magnitude and phase angle, which the User would expect its Demand to impose on the National Electricity Transmission System;
- (e) the maximum harmonic content which the User would expect its Demand to impose on the National Electricity Transmission System;
- (f) details of all loads which may cause Demand fluctuations greater than those permitted under Engineering Recommendation P28 Issue 2, Stage 1 at a Point of Common Coupling including the Flicker Severity Short Term and the Flicker Severity Long Term.
- (g) In the case of Electricity Storage Modules, details of the Maximum Capacity, Maximum Import Power, Registered Import Capability, charge time, discharge time and operating periods.

PC.G.2.5 Network Operators' System Data

PC.G.2.5.1 Introduction

PC.G.2.5.1.1 PC.G.2.6.1.2, PC.G. 2.6.1.4 to PC.G. 2.6.1.5 consist of data which is only to be supplied to The Company at The Company's reasonable request. In the event that The Company identifies a reason for requiring this data, The Company shall write to the relevant Network Operator(s), requesting the data, and explaining the reasons for the request. If the Network Operator(s) wishes, The Company shall also arrange a meeting at which the request for data can be discussed, with the objective of identifying the best way in which The Company's requirements can be met.

Where The Company makes a request to a Network Operator for dynamic models under PC.G.2.6.1.5, each relevant Network Operator shall ensure that the models supplied in respect of their Plant and Apparatus reflect the true and accurate behaviour of the Plant and Apparatus as built and verified through the Compliance Processes (CP's).

PC.G.2.6.1.2 User's Protection Data

**Commented [AC520]:** Each Network Operator shall provide The Company with the relevant data for  
But the sentence is incomplete

**Commented [AC521]:** I don't really understand what this is although I can see its existing PC.A text, although its currently only provided on request by The Company, and then only from Generators not NOs, so I think it needs to be deleted from PC.G.

**Formatted Table**

**Formatted Table**

**Commented [AC522]:** If needed the SI unit of time is 's'

**Commented [AC523]:** ditto

**Commented [AC524]:** ... (including the load behaviour of any. Electricity..

**Commented [AC525]:** Remove double spaces between words

**Commented [AC526]:** ...domestic. Commercial...

**Commented [AC527]:** Is there a 'typical' range of Electricity Storage load?  
It's not really clear what is called for - but its only infrequently required and only on request....

**Commented [AC528]:** ...industrial....

**Commented [AC529]:** ...of Demand to various....

**Commented [AC530]:** ...of the NETS..

**Commented [AC531]:** ...at the time of peak Active Power.

**Commented [AC532]:** This doesn't look right to me. This isn't the scope of PC.G.2.5.1.

**Commented [AC533]:** ...NETS.

**Commented [AC534]:** ...NETS.

**Commented [AC535]:** ...may cause voltage fluctuations....  
P28 is all about voltage fluctuations caused by demand fluctuations

**Commented [AC536]:** Which point of common coupling.  
Is this to do with PoCC between the customer and the NO's system or at a point between the DNO network and the NETS.

**Commented [AC537]:** ...the Flicker Severity (Short Term) and the Flicker Severity (Long Term).

Correct use of defined terms with brackets

**Commented [AC538]:** unbold

**Commented [AC539]:** unbold

**Commented [AC540]:** Check the numbering 2.5 or 2.6?

The following information is required which relates only to **Protection** equipment which can trip or inter-trip or close any **Connection Point** circuit-breaker or any **Transmission** circuit-breaker (or in the case of **OTSUA**, any **Interface Point** or **Connection Point** circuit breaker). This information need only be supplied once, in accordance with the timing requirements set out in PC.A.1.4(b), and need not be supplied on a routine annual basis thereafter, although **The Company** should be notified if any of the information changes;

- (a) a full description, including estimated settings, for all relays and **Protection** systems installed or to be installed on the **User's System**;
- (b) a full description of any auto-reclose facilities installed or to be installed on the **User's System**, including type and time delays;
- (c) a full description, including estimated settings, for all relays and **Protection** systems or to be installed on the generator, generator transformer, **Station Transformer** and their associated connections;
- (d) for **Generating Units** (including **Synchronous Generating Units** forming part of a **Synchronous Power Generating Module** but excluding **Power Park Units**) or **Power Park Modules** (including **DC Connected Power Park Modules**) or **HVDC Systems** or **DC Converters** at a **DC Converter Station** or **OTSDUW Plant and Apparatus** having (or intended to have) a circuit breaker at the generator terminal voltage, clearance times for electrical faults within the **Generating Unit** (including **Synchronous Generating Units** forming part of a **Synchronous Power Generating Module** but excluding a **Power Park Unit**) or **Power Park Module** (including **DC Connected Power Park Modules**) zone, or within the **OTSDUW Plant and Apparatus**;
- (e) the most probable fault clearance time for electrical faults on any part of the **User's System** directly connected to the **National Electricity Transmission System** including **OTSDUW Plant and Apparatus**; and
- (f) in the case of **OTSDUW Plant and Apparatus**, synchronisation facilities and delayed auto reclose sequence schedules (where applicable).

#### PC.G.2.6.1.3 Harmonic Studies

PC.G.2.6.1.3.1 It is occasionally necessary for **The Company** to evaluate the production/magnification of harmonic distortion on the **National Electricity Transmission System** and **User's Systems** (and **OTSUA**), especially when **The Company** is connecting equipment such as capacitor banks. At **The Company's** reasonable request, each **User** is required to submit data with respect to the **Connection Site** (and in the case of **OTSUA**, each **Interface Point** and **Connection Point**), current and forecast, and where not already supplied under PC.A.2.2.4 and PC.A.2.2.5, as follows:

PC.G.2.6.1.34.2 The minimum and maximum **Demand** (both MW and MVA) that could occur;

Harmonic current injection sources in Amps at the Connection voltage points. Where the harmonic injection current comes from a diverse group of sources, the equivalent contribution may be established from appropriate measurements;

Details of traction loads, eg connection phase pairs, continuous variation with time, etc;

An indication of which items of equipment may be out of service simultaneously during **Planned Outage** conditions.

#### PC.G.2.6.1.4 Dynamic Models

PC.G.2.6.1.4.1 It is occasionally necessary for **The Company** to evaluate the dynamic performance of **User's Plant and Apparatus** at each **EU Grid Supply Point** or in the case of **EU Code Users**, their **System**. At **The Company's** reasonable request and as agreed between **The Company** and the relevant **Network Operator** or **Non-Embedded Customer**, each **User** is required to provide the following data. Where such data is required, **The Company** will work with the **Network Operator** to establish the scope of the dynamic modelling work and share the required information where it is available;

- (e) Dynamic model structure and block diagrams including parameters, transfer functions and individual elements (as applicable);
- (f) Power control functions and block diagrams including parameters, transfer functions and individual elements (as applicable);
- (g) Voltage control functions and block diagrams including parameters, transfer functions and individual elements (as applicable);
- (h) Converter control models and block diagrams including parameters, transfer functions and individual elements (as applicable).

Where **The Company** makes a request to a **Network Operator** for dynamic models, the **Network Operator**, to the best of its ability, shall ensure that the models supplied in respect of the **Plant** and **Apparatus** reflect the true and accurate behaviour of the **Plant** and **Apparatus** as built and verified through the **Compliance Processes (CP's)**.

#### PC.G.2.6.1.5 Transient Overvoltage Assessment Data

PC.G.2.6.1.5.1 It is occasionally necessary for **The Company** to undertake transient overvoltage assessments (e.g. capacitor switching transients, switchgear transient recovery voltages, etc). At **The Company's** reasonable request, each **Network Operator** is required to provide the following data with respect to the **Connection Site**, as follows:

- (a) busbar layout plan(s), including dimensions and geometry showing positioning of any current and voltage transformers, through bushings, support insulators, disconnectors, circuit breakers, surge arresters, etc. Electrical parameters of any associated current and voltage transformers, stray capacitances of wall bushings and support insulators, and grading capacitances of circuit breakers;
- (b) Electrical parameters and physical construction details of lines and cables connected at that busbar. Electrical parameters of all plant not previously supplied as part of the Structural Data e.g., transformers (including neutral earthing impedance or zig-zag transformers, if any), series reactors and shunt compensation equipment connected at that busbar (or to the tertiary of a transformer) or by lines or cables to that busbar;
- (c) Basic insulation levels (BIL) of all Apparatus connected directly, by lines or by cables to the busbar;
- (d) characteristics of overvoltage Protection devices at the busbar and at the termination points of all lines, and all cables connected to the busbar;
- (e) the following data is required on all transformers operating at Supergrid Voltage throughout Great Britain and, in Scotland, also at 132kV or greater: three or five limb cores or single phase units to be specified, and operating peak flux density at nominal voltage;
- (f) an indication of which items of equipment may be out of service simultaneously during Planned Outage conditions

#### PC.G.2.7 Grid Forming Related Information

PC.G.2.7.1 The following data need only be supplied by **Network Operators** who wish to offer a **Grid Forming Capability** as provided for ECC.6.3.19.3. Where such a **Grid Forming Capability** is provided then the following data items and models are to be supplied.

- (iv) Each **GBGF-I** shall be designed so as not to interact and affect the operation, performance, safety or capability of other **User's Plant** and **Apparatus** connected to the **Total System**. To achieve this requirement, each **Network Operator** shall be required to submit a **Network Frequency Perturbation Plot** and **Nichols Chart** (or equivalent as agreed with **The Company**) which shall be assessed in accordance with the requirements of ECP.A.3.9.3.

Each **Network Operator** is required to supply a high-level equivalent architecture diagram of their **Grid Forming Plant** as shown in Figure PC.G.4.1.1 together with the equivalent linear classical block diagram model (using the Laplace Operator) of their **Grid Forming Plant** which should preferably be in the general form shown in Figure PC.G.4.1.1 (a) or Figure PC.G.4.1.1 (b). When submitting either Figure PC.G.4.1.1 (a) or Figure PC.G.4.1.1 (b), each **Network Operator** can use their own design, that may be very different to Figures PC.G.4.1.1 (a) or PC.G.4.1.1 (b) but should contain all relevant functions that can include simulation models and other equivalent data and documentation.

Each **User** shall provide a model of their **Grid Forming Plant** which provides a true and accurate reflection of its **Grid Forming Capability**.

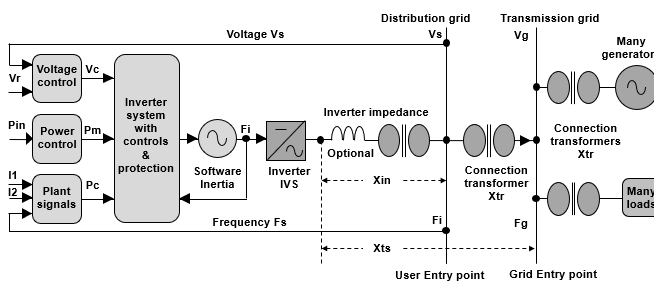

Figure PC.G.4.1.1

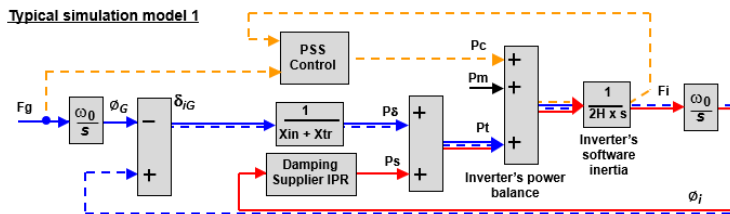

Figure PC.G.4.1.1 (a) Preferred simplified diagram of a **GBGF-I** with a **Power System Stabiliser "PSS"** that can add damping to the **GBGF-I's** closed loop function shown by the solid red line and the dotted blue line.

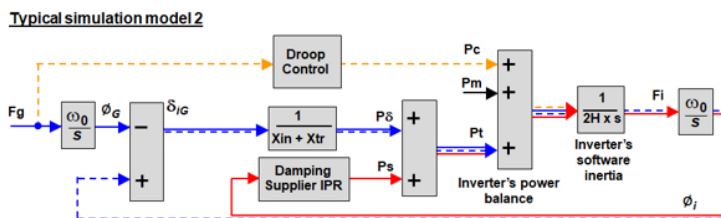

Figure PC.G.4.1.1 (b) – Preferred simplified diagram of a system with a droop control ability that can add **Control-Based Active Droop Power**. This diagram does not add extra closed loop damping to the **GBGF-I's** closed loop function shown by the solid red line and the dotted blue line.

(v) In order to participate in the **Grid Forming Capability** market, **Network Operator 's** and **Non-CUSC Parties** are required to provide data of their **GBGF-I** in accordance with Figures PC.G.4.1.1(a) and PC.G.4.1.1(b). **Network Operators** and **Non-CUSC Parties** in respect of **Grid Forming Plants** should indicate if the data is submitted on a unit or aggregated basis. Table PC.G.4.1.1(a) defines the notation used in Figure PC.5.8.1

<u>Parameter</u>	<u>Symbol</u>	<u>Units</u>
The primary reactance of the <b>Grid Forming Unit</b> , in pu.	$X_{in}$ or $X_{ts}$	pu on MVA Rating of <b>Grid Forming Unit</b>
The additional reactance, in pu, between the terminals of the <b>Grid Forming Unit</b> and the <b>Grid Entry Point</b> or <b>User System Entry Point</b> (if Embedded).	$X_{tr}$	pu on MVA Rating of <b>Grid Forming Unit</b>
The rated angle between the <b>Internal Voltage Source</b> and the input terminals of the <b>Grid Forming Unit</b> .		radians
The rated angle between the <b>Internal Voltage Source</b> and <b>Grid Entry Point</b> or <b>User System Entry Point</b> (if Embedded).		radians
The rated voltage and phase of the <b>Internal Voltage Source</b> of the <b>Grid Forming Unit</b> .		Voltage - pu Phase - radians
The rated electrical angle between current and voltage at the input to the Grid transformer.		radians

Table PC.G.4.1.1

(vi) In order to participate in a **Grid Forming Capability** market, **Network Operators** are also required to provide the data of their **GBGF-I** in accordance with Table PC.G.4.1.1.2 to **The Company**. The details and arrangements for **Network Operators** participating in this market shall be published on **The Company's Website**.

<u>Quantity</u>	<u>Units</u>	<u>Range</u> <u>(Where</u> <u>Applicable)</u>	<u>User Defined Parameter</u>



Type of <b>Grid Forming Plant</b> (eg <b>Generating Unit, Electricity Storage Module, Dynamic Reactive Compensation Equipment</b> etc)	<u>N/A</u>		
Maximum Continuous Rating at <b>Registered Capacity</b> or <b>Maximum Capacity</b>	<u>MVA</u>		
Primary reactance $X_{in}$ or $X_t$ s (see Table PC.G.4.1.1)	<u>pu on MVA</u>		
Additional reactance $X_r$ (See Table PC.G.4.1.1)	<u>pu on MVA</u>		
<b>Maximum Capacity</b>	<u>MW</u>		
<b>Active ROCOF Response Power</b> (MW) injected or absorbed at 1Hz/s <b>System Frequency</b> change (which is the maximum frequency change for linear operation of the <b>Grid Forming Plant</b> )	<u>MW</u>		
<b>Phase Jump Angle Withstand</b>	<u>degrees</u>		<u>60 degrees specified</u>
<b>Phase Jump Angle limit</b>	<u>degrees</u>		<u>5 degrees recommended</u>
<b>Phase Jump Power</b> (MW) at the rated angle	<u>MW</u>		
<b>Defined Active Damping Power</b> for a <b>Grid Oscillation Value</b> of 0.05 Hz peak to peak at 1 Hz	<u>MW</u>		
The cumulative energy delivered for a 1Hz/s <b>System Frequency</b> fall from 52 Hz to 47 Hz. This is the total <b>Active Power</b> transient output of the <b>Grid Forming Plant</b>	<u>MWs or MJ</u>		
<b>Inertia Constant (H)</b> using equation 1 or declared in accordance with the simulation results of ECP.A.3.9.4	<u>MWs/MVA</u>		
<b>Inertia Constant (He)</b> using equation 2 or declared in accordance with the simulation results of ECP.A.3.9.4	<u>MWs/MVA</u>		
Continuous Overload Capability	<u>% on MVA</u>		
Short Term duration Overload capability			

<u>Duration of Short-Term Overload Capability</u>	<u>s</u>		
<u>Peak Current Rating</u>	<u>Pu</u>		
<u>Nominal Grid Entry Point or User System Entry Point voltage</u>	<u>kV</u>		
<u>Grid Entry Point or User System Entry Point</u>	<u>- Location</u>		
<u>Continuous or defined time duration MVA Rating</u>	<u>MVA</u>		
<u>Continuous or defined time duration MW Rating</u>	<u>MW</u>		
<u>For a GBGF-I the inverters maximum Internal Voltage Source (IVS) for the worst-case condition – for example operation at maximum exporting Reactive Power at the maximum AC System voltage</u>	<u>pu</u>		
<u>Maximum Three Phase Short Circuit Infeed at Grid Entry Point or User System Entry Point</u>	<u>kA</u>		
<u>Maximum Single Phase Short Circuit Infeed at Grid Entry Point or User System Entry Point</u>	<u>kA</u>		
<u>Will the Grid Forming Plant contribute to any other form of commercial service – for example Dynamic Containment, Firm Frequency Response.</u>	<u>Details to be provided</u>		
<u>Equivalent Damping Factor.</u>	<u>Z</u>		<u>0.2 to 5.0 allowed</u>

Table PC.G.4.1.2

H = Installed MWs / Rated installed MVA

(equation 1)

He = (Active ROCOF Response Power at 1 Hz / s x System Frequency) / (Installed MVA x 2)

(equation 2)

PC.G.2.8 System Restoration Related Information

PC.G.2.8.1 Data identified under this section PC.G.2.8.1 must be submitted as required under PC.9.5.

PC.G.2.8.2 Where a **Network Operator** has a **Distribution Restoration Zone Plan** in place, the data specified in this section shall be submitted as required by **Network Operator(s)** to **The Company** annually by calendar week 28. This information may also be requested by **The Company** from the relevant **Network Operator(s)** during **System Restoration** and should be provided by **Network Operator(s)** where reasonably practicable. **Restoration Contractor's** party to a **Distribution Restoration Zone Plan** shall, where reasonably practicable, submit the relevant information to the **Network Operator** who shall then supply the relevant information to **The Company**. The following data shall be provided:

(a) The expected time for each **Restoration Contractor's Plant to Re-Synchronise** to the **Network Operator's System** following a **Total Shutdown** or **Partial Shutdown**. The assessment should include the **Restoration Contractor's** ability to **Re-Synchronise** all their **Plant** if all were running immediately prior to the **Total Shutdown** or **Partial Shutdown**. Additionally, the data and supporting text should highlight any specific issues (e.g., those that would affect the time before which the **Restoration Contractor's Plant** could be energised) that may arise as time progresses from **Shutdown** without external supplies being restored or the availability of primary fuel supplies.

(b) The **Restoration Contractor's Plants Block Loading Capability** as required in PC.G.2.8.1(b).

PC.G.2.8.3 From 31st December 2026 onwards, all **Users** are required to confirm annually they comply with the applicable requirements of OC5.7. In the case of **Network Operators** this confirmation shall be provided in their Week 28 submission. From 1st January 2024 until 31st December 2026, evidence to support the work **Network Operators** are carrying out to achieve these requirements on or after 31st December 2026 shall be provided in their Week 24 submission.

PC.G.3 Organisation of **PSM** data

PC.G.3.1 Sections 9 and 10 of the Planning Code require **The Company** and **Network Operators** to use **Solved PSMs** (Solved Power System Models) to describe the equipment, connectivity and operating condition of their portion of the **System**. This section explores how the data of a **Solved PSM** is organised.

Four main organizational concepts work together to allow the description of grid model data in building block 'modules'. These organizational constructs are:

- Profiles – Profiles divide data by type (Structural, Situation or Solution).
- Frames and Boundaries – Frames and Boundaries represent grid extents (sometimes call territories). A Frame is typically used to define a grid extent under the data mastership of one modelling party. A Boundary exists between Frames whose systems are connected.
- Models – Models are snapshots of grid objects representing a specific system or system operating condition.
- Assembly – Assemblies are collections of Models, typically for a specific purpose.

Section 9, Section 10, and Appendix G.1 reference the concept of Profiles extensively in the definition of data requirements. This Appendix will explore the other organisational concepts.

PC.G.3.2 Frame, Boundary, Model and Assembly concepts

Frames and Boundaries define grid extents which enable the maintenance of power system models in 'modules' which can be easily combined to create cohesive input data for various network analysis studies. Every Boundary is associated with two or more Frames. (Two is the most common number of Frames per Boundary, however, three or more Frames can be associated with a Boundary if necessary to accurately express the relationships among the systems of the various modelling-responsible parties.) There is an electrical connection between one or more pieces of equipment in the grid extent defined by each Frame and the equipment in the Boundary. All connections between the equipment of one Frame and that of another Frame (or set of Frames) are defined using a single Boundary.

Models contain grid objects which represent some facet of the portion of the power system contained in a Frame or Boundary. The grid objects in a Model all conform to a Profile describing a type of data. The Structural Profile describes information about the characteristics of electricity system equipment, including their capabilities and connectivity. The Situation Profile describes information about the operational state of an electricity system, including demand and generation output and switch positions. The Solution Profile describes information regarding the results of a steady-state power flow calculation and/or short circuit calculation performed by a power system modelling application.

Assemblies are collections of Models grouped to support a purpose. An Assembly can contain multiple Models whose data conforms to the same Profile or Models conforming to multiple different Profiles.

**PC.G.3.3 Organising grid model data using the four concepts**

Figure 11 illustrates how an electrical power system composed of a transmission system and 7 distribution systems could be divided into the Frames and Boundaries which delineate modelling responsibility.

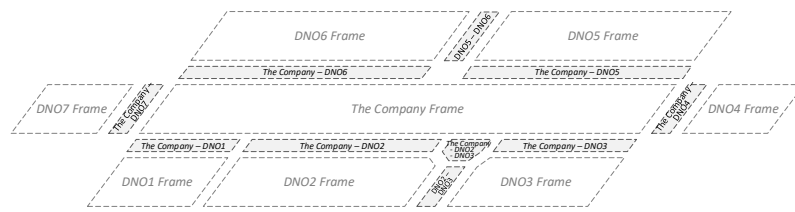

Figure 11 - Frames and Boundaries of a typical transmission and distribution power system

Seven **Network Operators** each have modelling responsibility for their own system – their Frames are labelled DNO1 Frame through DNO7 Frame. **The Company** has modelling responsibility for the transmission system - its Frame is called The Company Frame. There is a Boundary defined wherever the system of one Frame connects to the system of another Frame. In Figure 11, the system of every DNO Frame connects to the system of The Company Frame. These connections are reflected by the presence of The Company-DNO1, The Company-DNO2, The Company-DNO3, The Company-DNO4, The Company-DNO5, The Company-DNO6, and The Company-DNO7 Boundaries. The systems of the DNO2 and the DNO3 Frames connect to each other - the DNO2-DNO3 Boundary and DNO6-DNO7 Boundary, respectively, reflect these connections. Additionally, the systems of the DNO2 and DNO3 Frames happen to have shared connection points with the system of The Company Frame, thus there is one tri-lateral Boundary, The Company-DNO2-DNO3.

In the straightforward situation where a detailed master Structural model of the entire system is being constructed, each modelling-responsible party would create a Structural Model (a model of the equipment and connectivity of its system) describing the power system in its Frame. And each set of modelling-responsible parties whose Frames adjoin a given Boundary would agree on the modelling of their connections and would create a Structural Model for that Boundary. Each Structural Model would essentially 'fit into' or 'fill' its Frame or Boundary. This is illustrated in Figure 22.

Field Code Changed

Formatted: Font color: Text 1, English (United Kingdom)

Formatted: Font color: Text 1, English (United Kingdom)

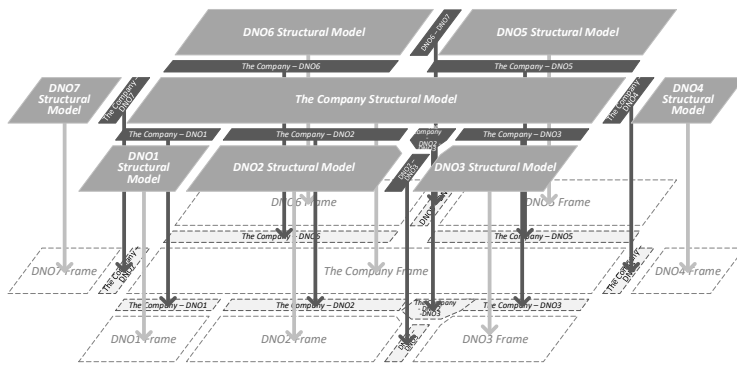

Figure 22 - Models 'fit into' Frames and Boundaries

The Structural grid model data that results from combining all the Models is complete, modular, and reflective of master modelling responsibility.

This collection of Models – the Structural Models which together describe the complete, master Structural data of the power system – could be shared as an Assembly (a collection of Models for a purpose), as shown in Figure 33.

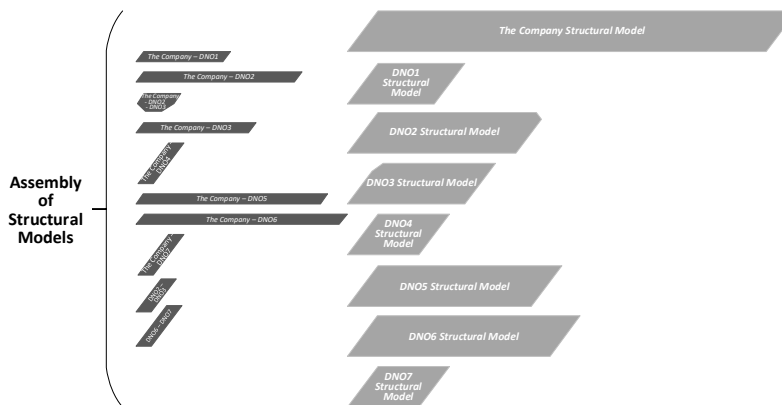

Figure 33 - An Assembly of Structural Models describing the equipment and connectivity of the complete power system

To describe the operating condition for a given study, the set of Structural Models could be augmented with Situation Models for each of the Frames. The Situation Models are shown in the upper portion of Figure 44.

Formatted: Font color: Text 1, English (United Kingdom)

Formatted: Font color: Text 1, English (United Kingdom)

Formatted: Font color: Text 1, English (United Kingdom)

Formatted: Font color: Text 1, English (United Kingdom)

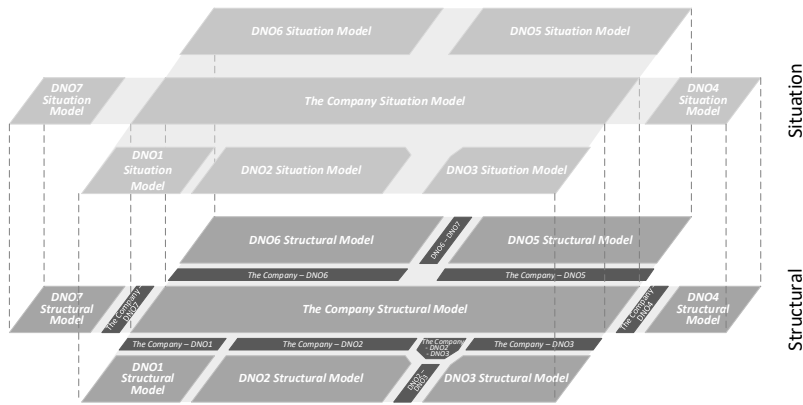
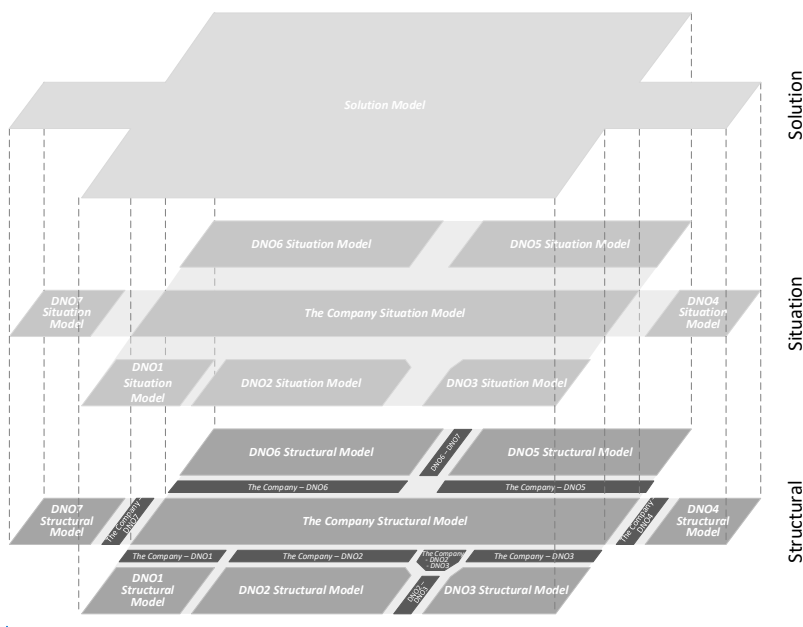

Figure 444 - A set of Situation Models augmenting their relevant Structural Models

Situation Models are typically needed only for Frames because Boundaries should not include equipment that needs to have Situation (system operating condition) data defined for it. An Assembly, made up of the Structural and Situation Models shown in Figure 44Figure 4, could be created to facilitate the sharing of the inputs necessary to run a given type of network analysis.

If the appropriate type of network analysis were run using the set of Structural and Situation Models shown in Figure 44Figure 4 as input, a single Solution Model for the entire power system would be created. It is shown at the top of Figure 55Figure 5, which, for context, also shows the Structural and Situation Models.



Field Code Changed

Formatted: Font color: Text 1, English (United Kingdom)

Formatted: Font color: Text 1, English (United Kingdom)

Formatted: Font color: Text 1, English (United Kingdom)

Field Code Changed

Figure 555 – A Solution Model created by network analysis using the relevant Structural and Situation Models as input

This complete case, composed of Models describing both the inputs and outputs of a specific network analysis execution, could also be shared as an Assembly.

#### PC.G.3.4 A Great Britain example

##### PC.G.3.4.1. Structural Models and their Frames and Boundaries

This section explores how grid objects in Models can connect across Frames and Boundaries using a very small, hypothetical portion of a system as an example. The orange outline in [Figure 66](#) indicates the portion of the power system presented in PC.G.3.2.1.1 which the small system example encompasses.

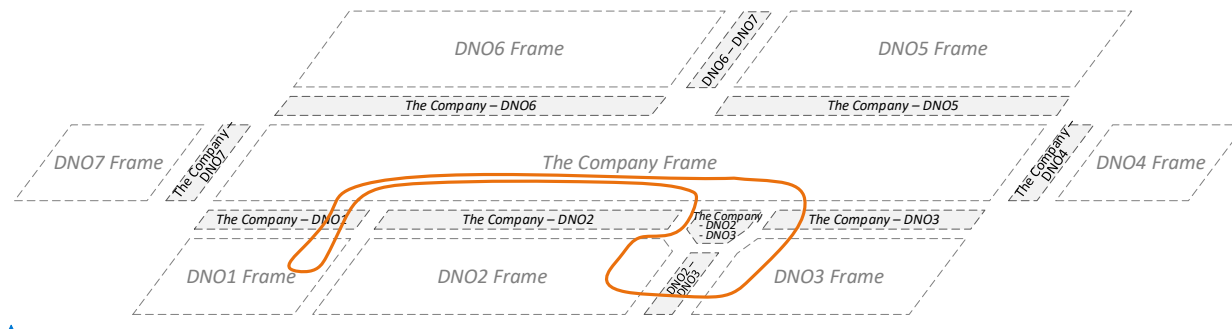

Figure 66 – Portion of the power system represented by the small system example

The small system example, whose schematic is shown in [Figure 77](#), reflects a variety of system configuration characteristics found in the Great Britain System. It focuses on points of connection among three Network Operator Systems and the NETS. The example has three substations:

- Substation A – A GSP substation where the DNO1 Network Operator System connects to the NETS. It is connected at a voltage level lower than that of Substation B and C and could be viewed as representing a GSP in Scotland.
- Substation B – A GSP substation where the Systems of the DNO2 and DNO3 Network Operators both connect to the NETS. It reflects an uncommon connection configuration, but one that is present in England
- Substation C – A GSP substation where the DNO3 Network Operator System connects to the NETS. It reflects a connection configuration commonly present in England.

The example also includes three types of connection configurations between the Systems of the DNO2 and DNO3 Network Operators. Additionally it contains a subtransmission line operated by The Company, which is connected to the low-voltage bus of Substation B and the high-voltage bus of Substation A.

Formatted: Font color: Text 1, English (United Kingdom)

Field Code Changed

Formatted: Font color: Text 1, English (United Kingdom)



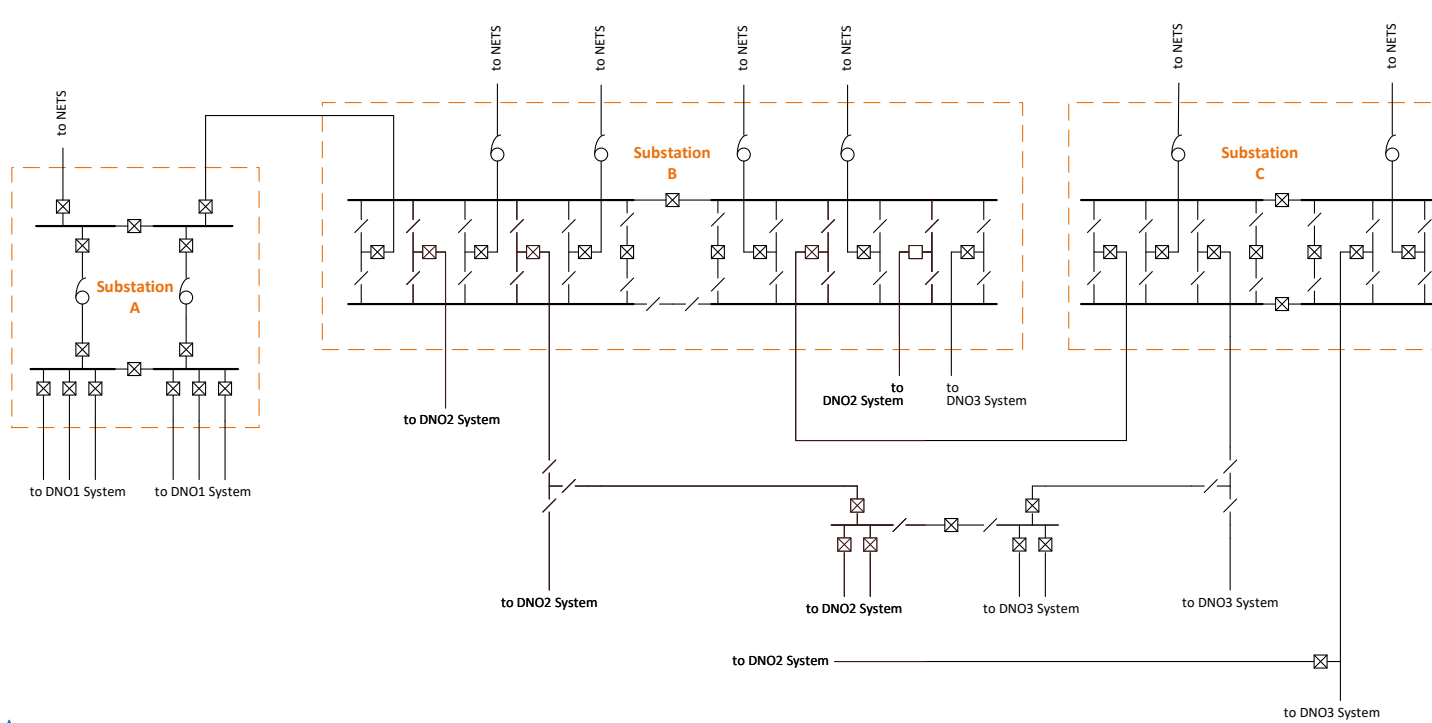

Field Code Changed

Figure 777 - Schematic of the small system example

The major grid objects used in a PSM representation of the small system example are superimposed on the schematic in [Figure 88](#).

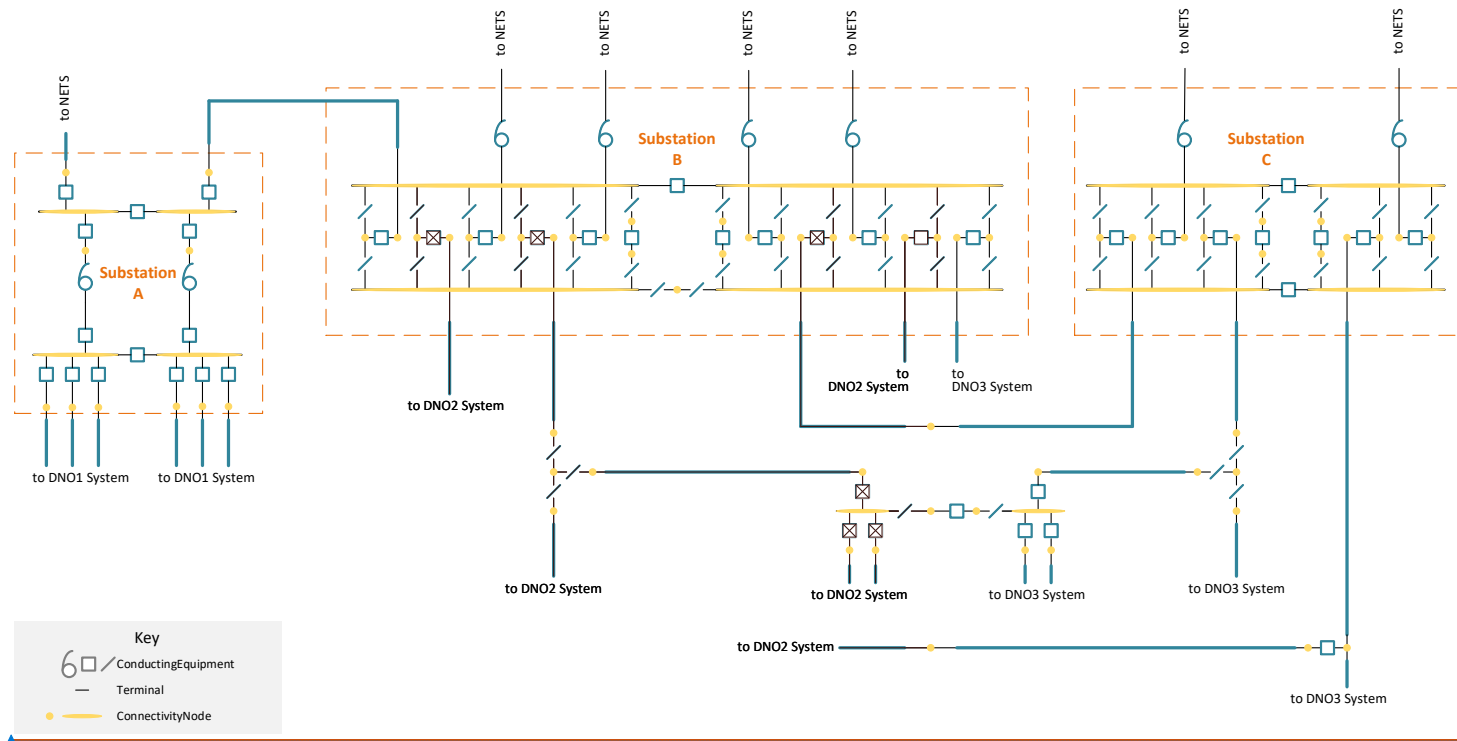

[Figure 88](#) – Foundational grid objects used to represent the equipment and connectivity of small system example

Formatted: Font color: Text 1, English (United Kingdom)

Field Code Changed

Figure 99 illustrates, using the small system example, the philosophy typically followed in allocating grid operating responsibility among **The Company** and **Network Operators**. The breakers and switches which couple busses and those which connect the main and transfer busses are the operating responsibility of the relevant **Network Operator** for Substations A and C because only one **Network Operator System** connects to the **NETS** at those substations. At Substation B, however, **The Company** has operating responsibility for the bus-connecting breakers and switches because two **Network Operators' Systems** connect to the **NETS** there.

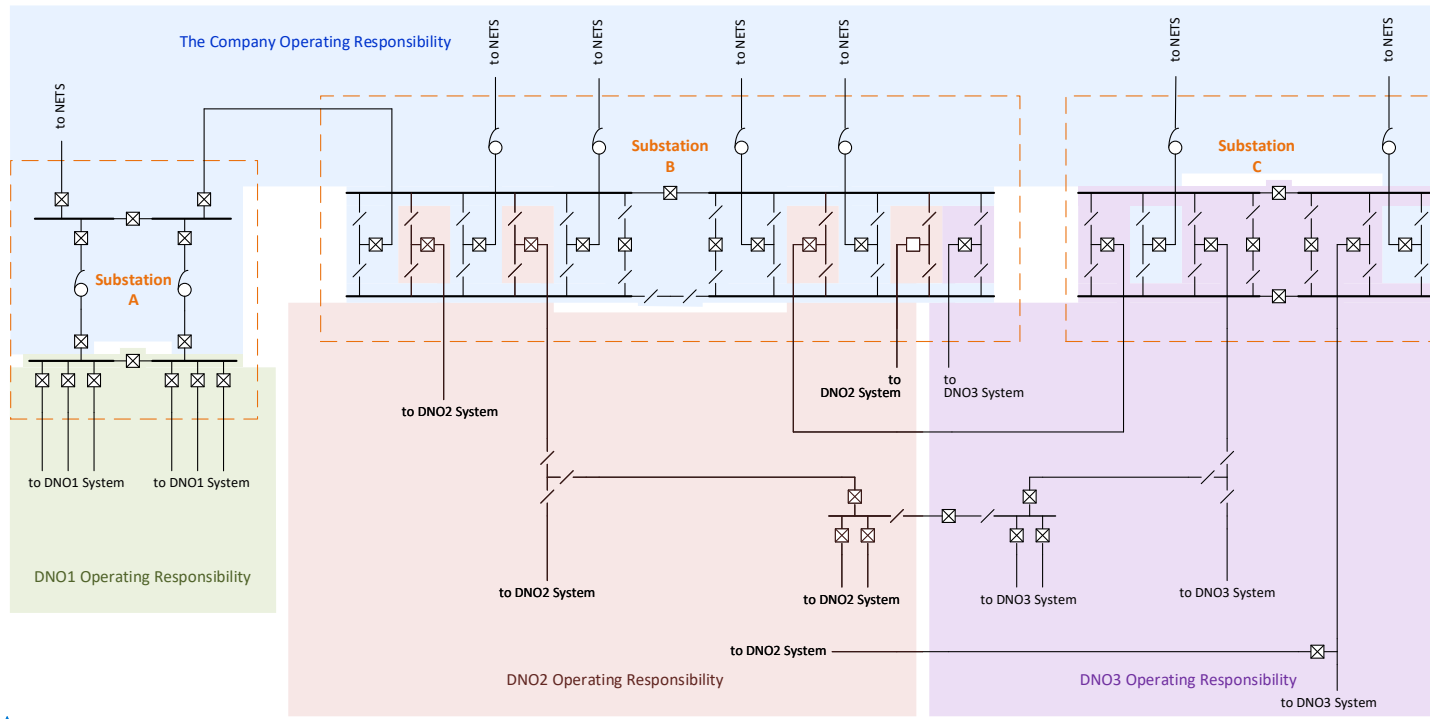

Figure 999 – Allocation of operating responsibility for the small system example

Formatted: Font color: Text 1, English (United Kingdom)

Field Code Changed

The decision has been taken to align modelling responsibility with operating responsibility in Planning Code data exchanges. The four Frames (The Company Frame, DNO1 Frame, DNO2 Frame and DNO3 Frame) and four Boundaries (The Company-DNO1, The Company-DNO2-DNO3, The Company-DNO3, and DNO2-DNO3) outlined in Figure 1010 Figure 10 reflect that decision.

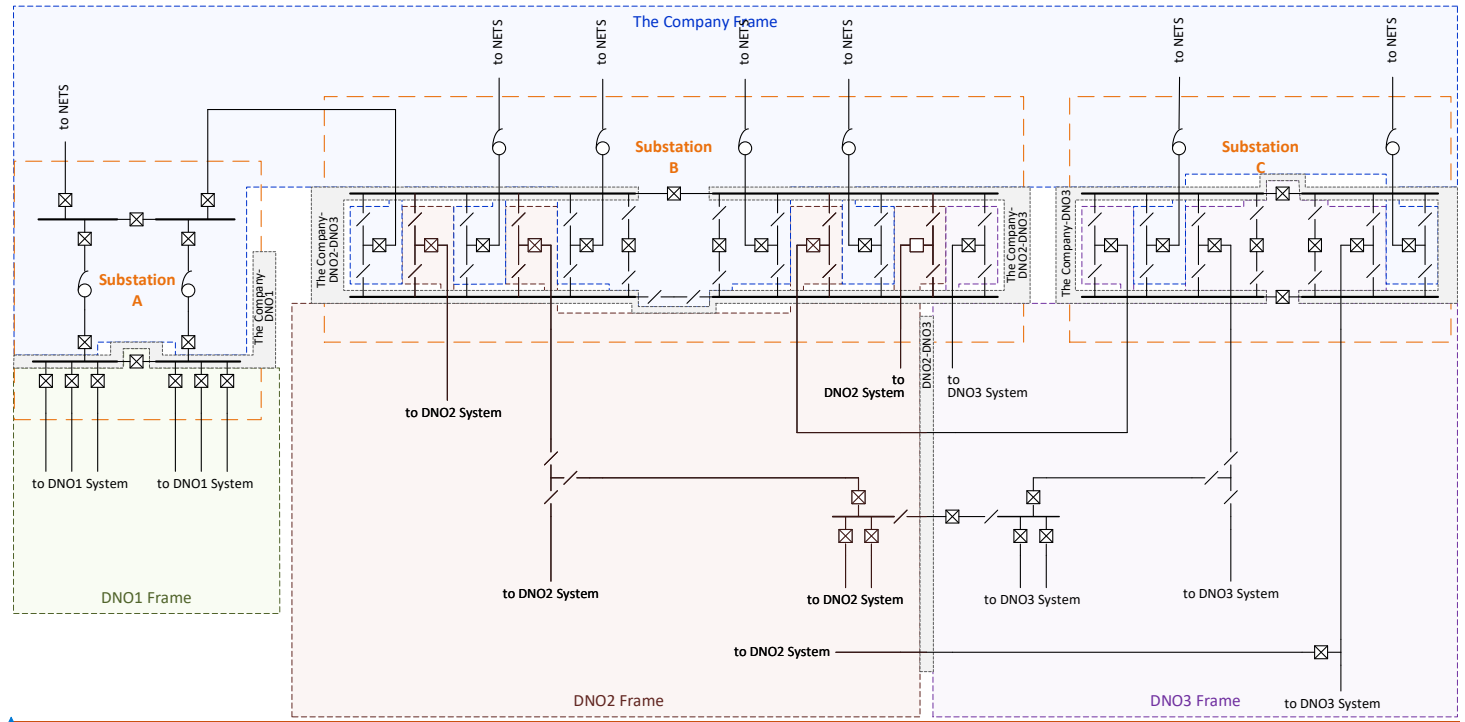

Figure 1010 - The Frames and Boundaries of the small system example

Formatted: Font color: Text 1, English (United Kingdom)

Field Code Changed

Figure 11114 shows the major grid objects contained in the various master Structural Models which 'fit into' each of the Frames and Boundaries of the small system example.

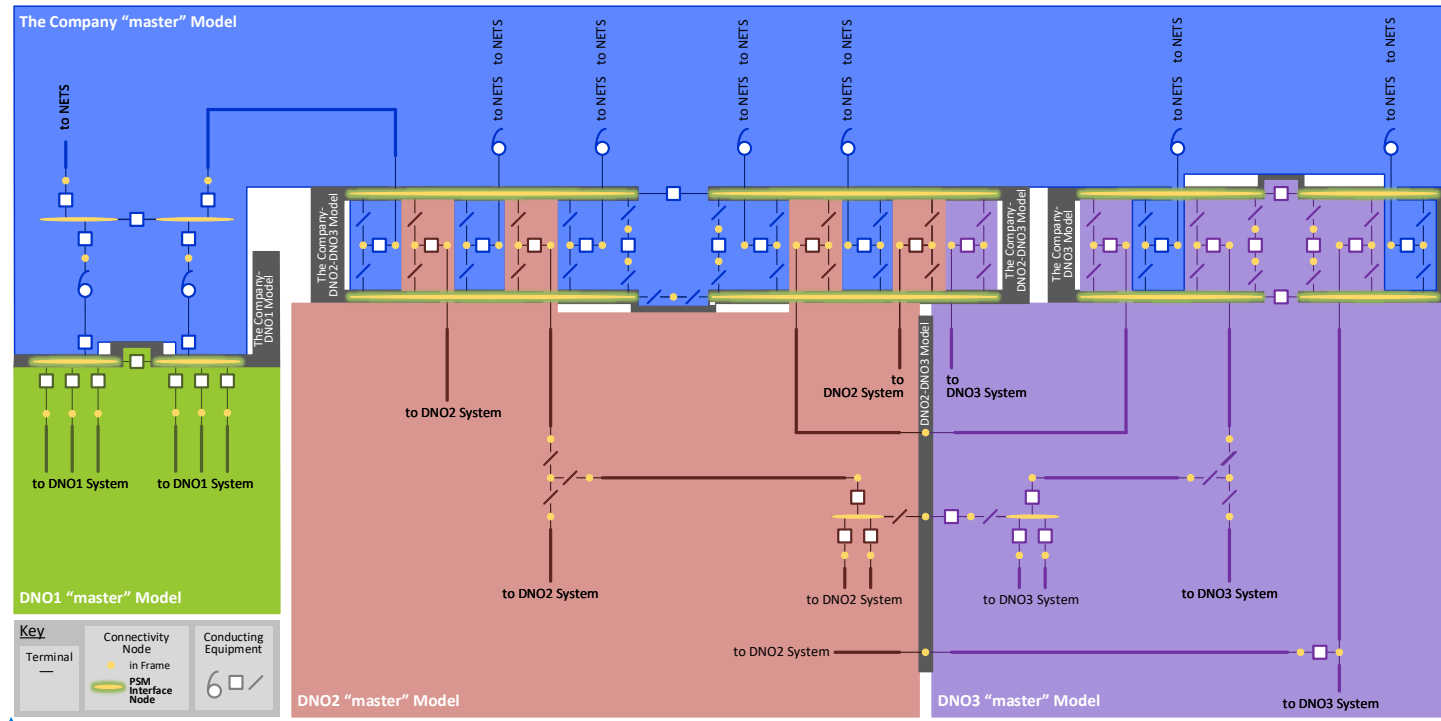

Figure 11114 – Major grid objects comprising the master Structural Models which 'fit into' each Frame and Boundary

Note that the only grid objects in the Structural Boundary Models in Figure 11114 are the Connectivity Nodes representing PSM Interface Nodes which are shown as gold oblongs with green glow.

Formatted: Font color: Text 1, English (United Kingdom)

Field Code Changed

Formatted: Font color: Text 1, English (United Kingdom)

PC.G.3.4.2 Assemblies for the exchange of **Solved PSMs**

The **Solved PSMs** required by Sections 9 and 10 are exchanged using **Assemblies of Models**. In creating their **Solved PSMs**, it is anticipated that both **The Company** and the **Network Operators** will execute a process similar to the following:

The **Solved PSM** creator performs studies in its own tool(s) using appropriately detailed models representing both its portion of the **System** and adjacent portions. When a study solution of suitable quality is achieved, the **Solved PSM** is created by trimming off the adjacent portions, leaving only the **Structural, Situation and Solution Models** which 'fit into' the creator's **Frame** along with the **Structural Models** which 'fit into' all **Boundaries** adjacent to the **Frame**.

The resulting **Solved PSM** Models are then submitted to the receiving party as an **Assembly**. Within the **Assembly**, there are references by grid objects in one **Model** to grid objects in other **Models**:

- Situation and Solution Frame Model grid objects point to grid objects in the Structural Frame Model.
- Structural Frame Model grid objects point to grid objects representing **PSM Interface Nodes** in Structural Boundary Models.

However, for the **Assembly** as a whole, there are no dangling references.

The receiving party typically uses the **Assembly** in the following manner:

- The Structural Frame Model is incorporated into the model of the receiving party's study tool, replacing the previous modelling for that Frame and connecting to the **PSM Interface Nodes** contained in the study tool model.
- The Situation and Solution Models are used as reference inputs into various studies set up and run by the receiver as part of its own business processes.

For the small system example outlined in PCG.3.4.1, the Models shown in **Figure 1212** would comprise the **Solved PSMs** submitted by **The Company** and by the **DNO1, DNO2** and **DNO3 Network Operators**.

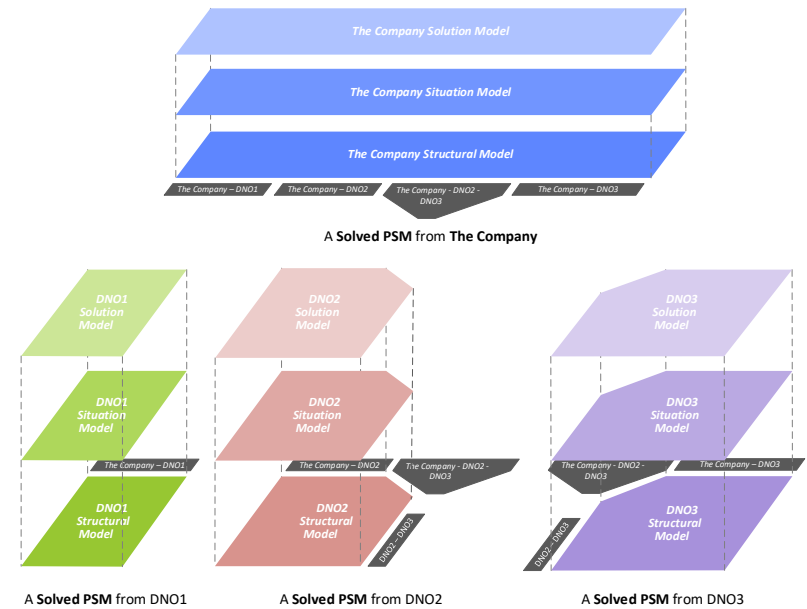

Figure 1212 – Models appearing the Solved PSMs from The Company and Network Operators

Field Code Changed

PC.G.4 PSM/PSDM data exchange standards

PC.G.4.1 The data of the **Solved PSMs** or **PSDMs** required under PC.9, PC.10, PC.G. and whose organisation is described in PC.G.3 shall conform to the schema and constraints defined by the designated data exchange profile standards listed in PC.G.4.1.1.

PC.G.4.1.1 The currently designated data exchange profile standard is defined by a **com**:

- IEC 61970-600-2:2021 Common Grid Model Exchange Specification (CGMES) - Exchange profiles specification, commonly known as CGMES v3.0; plus
- Planning Code-specific "deltas" from CGMES v3.0 as described in a GB Planning Code Power System Model Data Exchange Specification.

PC.G.4.2 Additional implementation guidance documents provide the population and exchange structure requirement definitions necessary to enable interoperable data exchange.

PC.G.4.3 Maintenance of the GB Planning Code Power System Model Data Exchange Specification, and of any related implementation documents, is the responsibility of GB CIM governance entity chartered under the auspices of a GB standards organisation.

PC.G.5 PSM Scenario Document

PC.G.5.1 A **PSM Scenario Document** shall be submitted to **The Company** as part of each **Network Operator's** submission in calendar weeks 2 and 28. A **PSM Scenario Document**, tailored to the individual **Network Operator**, shall be submitted to each **Network Operator** by **The Company** as part of its submission in calendar weeks 12 and 38. The aim of the **PSM Scenario Document** is to provide contextual information to help the receiving party better understand the submission and the assumptions made in developing it. The **PSM Scenario Document** shall contain:

PC.G.5.1.1 Information related to the content and creation of **Solved PSMs**, including:

PC.G.5.1.1.1 For the **Structural Data** underlying the **Solved PSMs** of a submission, the following:

- a) To be supplied by **Network Operators**
  - i. Descriptions of the simple representation of **HVDC Systems**.
- b) To be supplied by **The Company**
  - i. Descriptions of the simple representation of **HVDC Systems**.
  - ii. The identification of all schemes which are not completed as of the time of submission which are included in the **Structural Data of the Solved PSM**. Such schemes include **NETS** reinforcement, asset replacement, or similar schemes and new generation or load schemes where the relevant customer has accepted a connection offer from **The Company** to connect to the **NETS** but is not yet connected at the time of submission.

PC.G.5.1.1.2 For each **Solved PSM** in a submission, the following:

- a) To be supplied by **Network Operators**
  - i. A summary of the **grid conditions** reflected by the **Solved PSM** and any general information regarding the **Solved PSM** that would aid in its use.
  - ii. Description of running arrangements where they are different to that described by the **Situation Data** of the **Solved PSM** (e.g. where there is a different running arrangement in winter compared to summer, or modifications to the **Network Operator's System** due to the commissioning of a system reinforcement project).
  - iii. Demand and generation assumptions used in developing the **Situation Data** (e.g., generation dispatch assumptions like PV generation export being zero in the **NETS** peak demand **Solved PSM** on the basis that the **NETS** peak occurs when it's dark). These should address any differences in demand values between the **Solved PSM** and Schedules 21.

Formatted: Font: Not Bold

Commented [SM541]: Subgroup suggests PC.G.1

Commented [SM542]: Subgroup suggests "combination of"

Commented [SM543]: Subgroup suggests "to"

Commented [SM544]: Subgroup suggests "the"

Commented [SM545]: Subgroup suggests deleting this

Commented [SM546]: Subgroup suggests "the GB CIM Governance Group"

Commented [AC547]: ...Solved PSM(s)....

Commented [AC548]: bold

Commented [AC549]: bold

Commented [AC550]: Elsewhere we explain what 'schemes' means ie new connection, reinforcement and asset replacement.

Consistency would be good.

The identification of each new or modified generation connection where the customer has accepted a connection offer, authorised reinforcement, asset replacement scheme, which are not completed as of the time.....

Commented [SM551]: Subgroup suggests "are nearing completion"

Commented [AC552]: Does this mean NETS conditions ????

???????

Commented [SM553]: Subgroup suggests "Network Operator's System conditions"

Commented [SM(554): Subgroup suggests to change this to "different post outage running arrangement"

iv. Where the information is known by the **Network Operator**, the extent to which any customer demand has been influenced by a flexible demand contract with any party.

v. For fault level **Solved PSMs**, a description of the process by which fault levels were calculated, including any running arrangements changes required to maintain fault level headroom.

b) To be supplied by **The Company**

i. A summary of the condition(s) specified in PC.10.3.2.1 a) or PC.10.3.3.1 a), as applicable, which are represented by each **Solved PSM** and any general information regarding the **Solved PSM** that would aid in its use. In the case of the low and high power transfer **Solved PSMs**, this would include an indication of the direction of flow (e.g., north to south).

ii. Description of changes to current running arrangements as a result of planned modifications to the **NETS** which are included in the summer or winter **Structural Data**, and which reflect future not-yet-commissioned reinforcement or asset replacement schemes or generator or load connections.

iii. Demand and generation assumptions used in developing the **Situation Data** (e.g., generation dispatch assumptions, or how generation injections were adjusted to accommodate new, not-yet-connected generation included in the summer/winter **Structural Data**, or how demand and/or generation injections supplied by **Network Operators** were modified to facilitate power flow convergence or specific **Real Power (P)** and **Reactive Power (Q)** results at the **PSM Interface Nodes**<sup>2</sup>).

iv. Dispatch assumptions for external **HVDC Systems**, including both export and import.

v. For fault level **Solved PSMs**, a description of the process by which fault levels were calculated including any running arrangement changes required to maintain fault level headroom.

vi. An identification of known discrepancies in the **Structural Data**, **Situation Data** or **Solution Data** due to changes occurring during the timeframe the **Solved PSM** was being built. Such discrepancies are assumed to be minor as any change occurring during the construction process with significant impact should have been incorporated into the **Solved PSM**.

**Commented [SM(555)]:** Subgroup suggests adding a point vi "Details of the reconfiguration plan as required in PC.G.5.1.3.1 c)"

**Commented [AC556]:** Subgroup suggest replace v. with:  
For fault level **Solved PSMs**, a description of the assumptions made in the process of developing the **Situation Data** used in the fault level **Solved PSM** e.g. generation energisation / export and running arrangement assumption.

**Formatted:** Font: Not Bold

**Commented [AC557]:** Subgroup suggest replace clause v. with:

For fault level **Solved PSMs**, a description of the assumptions made in the process of developing the **Situation Data** used in the fault level **Solved PSM** e.g. generation energisation / dispatch and running arrangement assumptions.

**Commented [AC558]:** Sub group got as far as here on 15 Nov 2024

**Formatted:** Highlight

**Commented [AC559]:** ...to accommodate import to demand customers or export from generation....

PC.G.5.1.2 Information helpful in utilising the **Solved PSMs** including:

PC.G.5.1.2.1 Descriptions of network constraints, for example:

a) To be supplied by **Network Operators**

i. Any constraints which could impact the capability of the **Network Operator's System** to supply demand and/or generation under normal operational conditions. For example, this could include a limit of the import from and/or the export to a **Connection Point** implemented by an **Active Network Management** scheme.

b) To be supplied by **The Company**

i. Any **NETS** operational schemes that could have an impact on the **Network Operator's System**.

PC.G.5.1.2.2 Descriptions of **NETS** additional capabilities, for example:

a) To be supplied by **The Company**

ii. Guidance on the generation connected to the **NETS** whose output could be modified by a **Network Operator** to facilitate modelling outside the standard exchanged scenarios.

**Commented [AC560]:** Are a) I and ii examples of 'NETS additional capability'?

**Commented [AC561]:** I didn't follow this. NOs can't modify the output from generation. Do we mean modify the modelled output from generation



iii. Guidance on the HVDC plant connected to the NETS whose output could be modified by a Network Operator to facilitate modelling outside the standard exchanged scenarios.

PC.G.5.1.2.3 Descriptions of remedial actions, for example:

a) To be supplied by The Company

i. A description of changes to the NETS so that the Network Operator may undertake analysis of the impact of additional operational arrangements outside the standard data exchange envelope.

PC.G.5.1.2.4 Descriptions of additional network constraint scenarios, for example:

a) To be supplied by Network Operators

i. A description of additional actions that would be taken with respect to their System when analyzing a scenario outside the ones included in the information exchanges defined in PC.9.

b) To be supplied by The Company

i. A description of additional actions that would be taken with respect to the NETS when analyzing a scenario outside the ones included in the information exchanges defined in PC.10.

PG.5.1.3 Information related to Schedules supplied by Network Operators, including:

PC.G.5.1.3.1. For Schedules 21B and 21F, the following post fault Network Operator System layout information:

- a) The specified Connection Point assessment period that is being evaluated; and
- b) An accurate and unambiguous description of the Transmission Interface Circuits considered to be switched out due to a fault; and
- c) The reconfiguration plan to transfer demand from one Connection Point to another Connection Point. Details of the switching operation or reconfiguration which implements any demand transfer, including arrangements for undertaking actions (e.g. the time taken, automatic or manual and any other appropriate information), shall be provided for:
  - i. Those actions which would be implemented for a first planned outage.
  - ii. Those actions that would be implemented following a subsequent fault outage during a planned outage.

The Network Operator must not submit any action that it does not have the capability or the intention to implement during the assessment period specified (subject to there

PC.G.6 PSM Change Document

PC.G.6.1 A PSM Change Document shall be submitted as part of each Network Operator submission in calendar weeks 2 and 28 and each submission made by The Company in calendar weeks 12 and 38. The aim of the PSM Change Document is to provide contextual information to help the receiving party understand what has changed in the Solved PSMs of this submission relative to previously submitted Solved PSMs. The PSM Change Document shall contain:

PC.G.6.1.1 Information related to the content of Solved PSMs, including:

PC.G.6.1.1.1 An overview of the major changes to Structural Data between this submission's Solved PSMs and the previous submission's Solved PSMs.

a) To be supplied by Network Operators

i. A description, including the purpose and in-service date, of any new or modified connections or alterations to the Network Operator's System whose changes are included in the Structural Data of this submission's Solved PSM but were not represented in the Structural Data of the previous submission's Solved PSM.

Commented [AC562]: I didn't follow this. NOs can't modify the output from HVDC. Do we mean modify the modelled output from HVDC

Commented [AC563]: Is 'remedial' action correct?

Commented [AC564]: Not sure I really understand what this means

Commented [AC565]: Actions? The examples refer to additional actions

Commented [AC566]: Not sure I really understand what this means

Commented [AC567]: Not sure I really understand what this means

Commented [AC568]: I'm sure this sentence could be combined with 5.1.3.1

Commented [SM(569)]: Subgroup suggests after "plan" insert ", as described in the PSM Scenario Document,"

Commented [AC570]: Some words missing from here

Commented [AC571]: Unbold full stop

Commented [AC572]: I wonder if the following is clearer that the comparison is only with the most recent Solved PSMs rather than multiple historic versions

...in the Solved PSMs of the current submission relative to the Solved PSMs of the previous submission.

Commented [AC573]: I wonder if the following is clearer that the comparison is only with the most recent Solved PSMs rather than multiple historic versions

...between the Solved PSMs of the current submission and the Solved PSMs of the previous submission.

Commented [AC574]: Unbold

- ii. A description of any other changes to the **Structural Data** of this submission's **Solved PSM** in respect of the previous submission's **Solved PSM**. Other changes could be, for example, the renaming of an asset, the inclusion of new type of data, or changes to operating parameters like ratings or normal positions of taps or switches.

Commented [AC575]: ??

Commented [AC576]: ...transformer tap position...

**b) To be supplied by The Company**

- i. A description, including the purpose and in-service date, of any new or modified connections or alterations to the **NETS** whose changes are included in the **Structural Data** of this submission's **Solved PSM** but were not represented in the **Structural Data** of the previous submission's **Solved PSM**.
- ii. A description including the purpose and reason for non-implementation of each delayed or cancelled connection or alteration to the **NETS** whose changes were included in the **Structural Data** of the previous submission's **Solved PSM** but which are not represented in the **Structural Data** of this submission's **Solved PSM**.
- iii. A description of any other changes to the **Structural Data** of this submission's **Solved PSM** in respect of the previous submission's **Solved PSM**. Other changes could be, for example, the renaming of an asset, the inclusion of new type of data, or changes to operating parameters like ratings or normal positions of taps or switches.

PC.G.6.1.1.2 A description of any significant changes in the assumptions, approach, or inputs used in the creation of **Situation Data** between the **Solved PSMs** of this submission and the **Solved PSMs** of the previous submission.

**a) To be supplied by Network Operators**

- i. A description of significant differences between a **Solved PSM** and its previous version in respect of demand or generation patterns, constraints, or running arrangements (e.g., commissioning of a new Active Network Management scheme in **Network Operator's System** to manage power flow at a **Connection Point**, or a newly implemented curtailment agreement, or unusual growth of EV-related demand at a given substation).
- ii. For the **Situation Data** of **Solved PSMs** providing steady state power flow information, a description of any changes made to the process by which the **Situation Data** is created (e.g., changes have been made in the treatment of the import to **Electricity Storage**, or a new technique is being used for calculating historic demand or generation values from field monitored data, or improved mechanics are being used to 'fit' **Situation Data** reflective of a particular grid condition to the **Structural Data** reflective of the **Data Freeze Date**).
- iii. For the **Situation Data** of **Solved PSMs** providing fault level information, a description of any changes made to the process by which fault level data is created (e.g., new software or a new process is being used to perform fault level calculations, or an improved mechanism is being used to determine demand short circuit contributions).

**b) To be supplied by The Company**

- i. A description of significant differences between a **Solved PSM** and its previous version in respect of demand or generation patterns, constraints, or running arrangements (e.g., a change to the permitted export from parts of the **NETS** due to dispatch related constraints on the **NETS** becoming permanent, or a changed summer operating arrangement due to a new demand customer).
- ii. For the **Situation Data** of **Solved PSMs** providing steady state power flow information, a description of any changes made to the process by which the

Situation Data is created (e.g., changes have been made to demand or generation prediction techniques, or a new philosophy for designing of-normal running arrangements has been implemented).

- iii. For the **Situation Data of Solved PSMs** providing fault level information, a description of any changes made to the process by which fault level data is created (e.g., new software or a new process is being used to perform fault level calculations, or an improved mechanism is being used to determine demand short circuit contributions).

PC.G.7 Assessment of Site Compliance process

Commented [AC577]: How does this link to PC.7?

PC.G.7.1 **The Company** shall submit in writing no later than calendar week 7 in each year changes to:

- a) the calendar weeks defining the proposed start and finish of each **Access Period** for each **Transmission Interface Circuit**; and
- b) the **Connection Points** in each **Access Group**.

Commented [AC578]: ...weeks that in previous years defined the proposed start....?

Where it is not possible to avoid overlapping **Access Periods**, **The Company** will indicate to **Network Operators** its initial view of which **Transmission Interface Circuits** will need to be considered out of service concurrently for the purpose of assessing compliance to **Licence Standards**.

Commented [AC579]: ...with...

Rather than Licence Standards isn't it just NETS SQSS?

PC.G.7.2 Both **The Company** and the relevant **Network Operator(s)** shall use their reasonable endeavours to agree the appropriate **Access Group(s)** and **Access Period** for each **Transmission Interface Circuit** prior to week 17 in each year.

Commented [AC580]: Delete 'both'

PC.G.7.3 **Network Operators**, in calendar week 28, shall submit the data detailed in PC.9.3.3.6 and PC.9.3.3.7.

PC.G.7.4 Following the submission of data by a **Network Operator**, **The Company** shall perform assessments to verify whether **Connection Points** are compliant with the relevant **Licence Standards**. This shall include indicating which **Transmission Interface Circuits** will need to be considered out of service concurrently for the purpose of assessing compliance.

Commented [AC581]: Is this correct. Does the ESO do the assessment or the TO?

Is the ESO bound by licence to comply with SQSS. I thought it was but then read some things in the new ESO licence that suggested it wasn't.

PC.G.7.5 Where the result of any assessment identifies possible future non-compliance with the relevant **Licence Standards**, **The Company** shall notify the relevant **Network Operator(s)** of this fact as soon as reasonably practicable and shall agree with **Network Operator(s)** any opportunity to resubmit data to allow for a reassessment.

Commented [AC582]: unbold

Commented [AC583]: Indicating to who?

PC.G.7.6 Following any notification by **The Company** to a **Network Operator** pursuant to PC.G.7.2, and following any further discussions held between the **Network Operator** and **The Company**, revisions may be agreed to the **Access Periods** for relevant **Transmission Interface Circuits**. Such revisions shall not however permit an **Access Period** to be less than 4 continuous weeks in duration or to occur other than between calendar weeks 10 and 48 (inclusive).

Is identifying a better word

Commented [AC584]: Requirement ?

Commented [AC585]: Delete 'held'

PC.G.7.7 Thereafter, by calendar week 6 of the following year, as specified in PC.10.3.2.2, **The Company** shall notify the **Network Operator** of the results of any relevant assessment.

Commented [AC586]: By calendar.....

PC.G.7.8 When it is agreed by either **The Company** or **Network Operator(s)** that any resubmission of data is unlikely to confirm future compliance with the relevant **Licence Standards** the **Modification** process in the **CUSC** may apply.

Commented [AC587]: Clarify if agreement is required by both parties or whether the view of one party is OK

Commented [AC588]: ...Standards, **The Company** and the **Network Operator(s)** shall agree the best way of addressing the forecast non-compliance.

PC.G.7.9 The correlation among **Connection Point**, **Access Group**, **Access Period** and **Transmission Interface Circuit**:

Commented [AC589]: I'm confused about the purpose of this clause.

a) **Connection Points** have one or more **Transmission Interface Circuits**. **Transmission Interface Circuits** have one, and only one **Connection Point**.

Commented [AC590]: I think that by definition there needs to be more than one Connection Point in an Access Group

b) **Access Groups** are made up of one or more **Connection Points**. Each **Connection Point** must belong to one, and only one, **Access Group**.

**Access Groups** are made up of more than one **Connection Points**

Commented [AC591]: Unbold

c) Each **Transmission Interface Circuit** must have an **Access Period**, which shall:

Commented [AC592]: As above I don't think a Connection Point needs to belong to an Access group at all.

Commented [AC593]: Only where the TIC is actually in an Access Group.....

- i. normally be a minimum of 8 continuous weeks and can occur in any one of three maintenance years during the period from calendar week 13 to calendar week 43 (inclusive) in each year; or,
- ii. exceptionally and provided that agreement is reached between **The Company** and the relevant **Network Operator(s)**, the **Access Period** may be of a period not less than 4 continuous weeks and can occur in any one of three maintenance years during the period from calendar week 10 to calendar week 43 (inclusive) in each year.

**Commented [AC594]:** At present such a decision needs to be notified to Ofgem.

PC.G.8 Generation

PC.G.8.1 EnergySource types are listed below:

<u>Advanced Fuel (produced via gasification or pyrolysis of biofuel or waste)</u>
<u>Biofuel - Biogas from anaerobic digestion (excluding landfill &amp; sewage)</u>
<u>Biofuel - Landfill gas</u>
<u>Biofuel - Sewage gas</u>
<u>Biofuel - Other</u>
<u>Biomass</u>
<u>Fossil - Brown coal/lignite</u>
<u>Fossil - Coal gas</u>
<u>Fossil - Gas</u>
<u>Fossil - Hard coal</u>
<u>Fossil - Oil</u>
<u>Fossil - Oil shale</u>
<u>Fossil - Peat</u>
<u>Fossil - Other</u>
<u>Geothermal</u>
<u>Hydrogen</u>
<u>Nuclear</u>
<u>Solar</u>
<u>Stored Energy (all stored energy irrespective of the original energy source)</u>
<u>Waste</u>
<u>Water (flowing water or head of water)</u>
<u>Wind</u>
<u>Other</u>

**Commented [VG595]:** This is different from the existing schedule Table 11(d)

PC.G.8.2 Energy Source types map to Aggregated Energy Source types as shown below:

<u>Energy Source</u>	<u>Aggregated Energy Source</u>
<u>Advanced Fuel (produced via gasification or pyrolysis of biofuel or waste)</u>	<u>Advanced Fuel</u>
<u>Biofuel - Biogas from anaerobic digestion (excluding landfill &amp; sewage)</u>	<u>Biofuel</u>
<u>Biofuel - Landfill gas</u>	
<u>Biofuel - Sewage gas</u>	
<u>Biofuel - Other</u>	
<u>Biomass</u>	<u>Biomass</u>
<u>Fossil - Brown coal/lignite</u>	<u>Fossil</u>
<u>Fossil - Coal gas</u>	
<u>Fossil - Gas</u>	
<u>Fossil - Hard coal</u>	
<u>Fossil - Oil</u>	
<u>Fossil - Oil shale</u>	
<u>Fossil - Peat</u>	
<u>Fossil - Other</u>	
<u>Geothermal</u>	<u>Geothermal</u>
<u>Hydrogen</u>	<u>Hydrogen</u>
<u>Nuclear</u>	<u>Nuclear</u>
<u>Solar</u>	<u>Solar</u>
<u>Stored Energy (all stored energy irrespective of the original energy source)</u>	<u>Stored Energy</u>
<u>Waste</u>	<u>Waste</u>
<u>Water (flowing water or head of water)</u>	<u>Water</u>
<u>Wind</u>	<u>Wind</u>
<u>Other</u>	<u>Other</u>

PC.G.9 Submission Cycle

PC.G.9.1 The diagram below illustrates the annual, coordinated process of submissions between Network Operators and The Company.

**Commented [AC596]:** Transmission Owner isn't a GC term - Relevant Transmission Licensee.  
Text seems too small to read - I need to print it off to read  
There are some XXs  
Need to understand the week 38 and week 42 dashed line

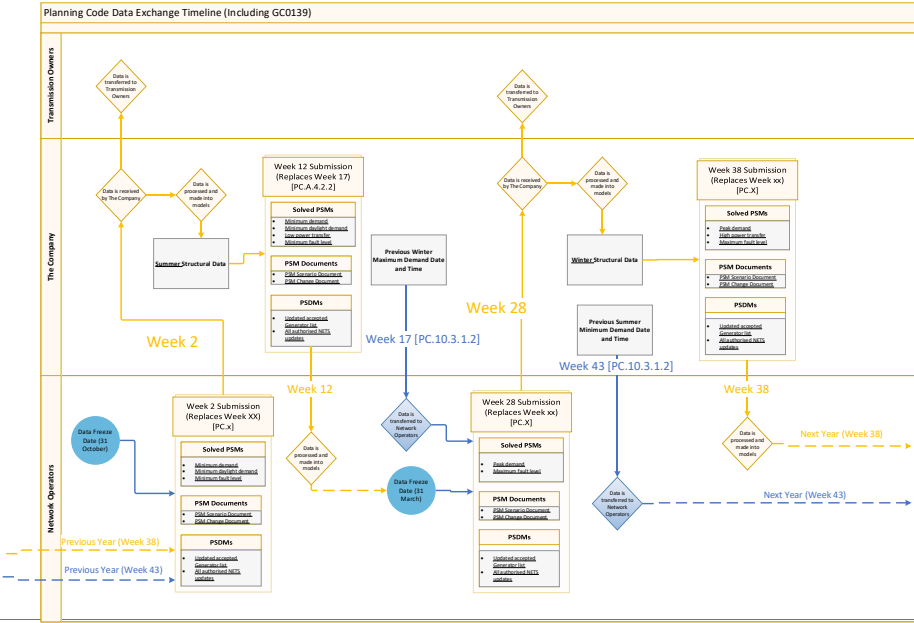
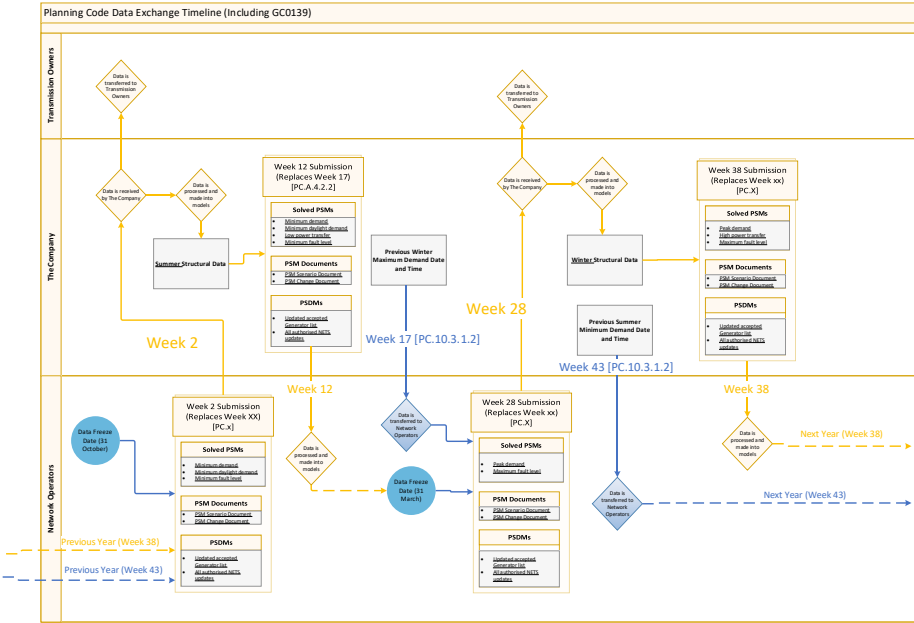

Planning Code Data Exchange Timeline (Including GC0139)

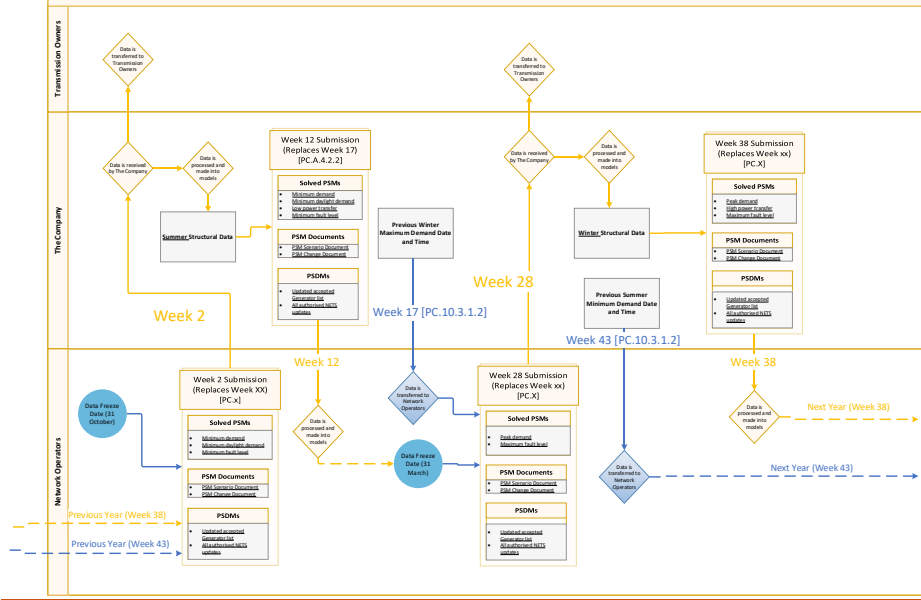

< END OF PLANNING CODE >

