

Distributed ReStart



Energy restoration
for tomorrow

Organisational, Systems
and Telecommunications
design stage I

In partnership with:



nationalgridESO

Contents



Executive summary	03
Introduction	09
1 Introduction	10
2 Key challenges	11
3 Industry engagement	16
4 Assumptions	19
5 Distributed ReStart Zone	21
Organisations and processes	22
6 Organisational introduction	23
7 Process requirements	27
8 Process design	46
9 Distributed ReStart Zone controller	54
10 Organisational design	59
Operational telecommunications	68
11 Operational telecommunications	69
12 Summary of existing operational telecommunications and viability report	71
13 Operational telecommunications requirements	73
14 Cost analysis of meeting functional specification	78
15 Cyber security	87
16 Operational telecommunications next steps	92
Systems and DER interfaces	93
17 Systems	94
18 DER control interface	98
19 Recommendations and next steps	100
Appendices	103
20 Bibliography	104
21 RAID log	105
22 Terminology	106

Abstract

The Distributed ReStart project is a partnership between National Grid Electricity System Operator (NGESO), SP Energy Networks (SPEN) and TNEI (a specialist energy consultancy) that has been awarded £10.3 million of Network Innovation Competition (NIC) funding.

The project is exploring how Distributed Energy Resources (DER) can be used to restore power in the highly unlikely event of a total or partial shutdown of the National Electricity Transmission System. Past and current approaches rely on large power stations but as the UK moves to cleaner, greener and more decentralised energy, new options must be developed. The enormous growth in DER presents an opportunity to develop a radically different approach to system restoration. Greater diversity in Black Start provision will improve resilience and increase competition leading to reductions in both cost and carbon emissions. However, there are significant technical, organisational and commercial challenges to address.

The project will tackle these challenges in a three-year programme (Jan 2019 – Mar 2022) that aims to develop and demonstrate new approaches, with initial implementations of Black Start service from DER from mid-2022 if deemed feasible and cost effective. Case studies on the SP Distribution (SPD) and SP Manweb (SPM) networks will be used to explore options, then design and test solutions through a combination of detailed off-line analysis, stakeholder engagement and industry consultation, desktop exercises, and real-life trials of the re-energisation process.

Project description

The project is made up of five workstreams. The Project Direction and Knowledge Dissemination workstreams cover the effective management of the project and sharing of learning. The other three workstreams cover the wide range of issues to enable Black Start services from DER:

The Organisational, Systems and Telecommunications (OST) workstream is considering the DER-based restoration process in terms of the different roles, responsibilities and relationships needed across the industry to implement at scale. It will specify the requirements for information

systems and telecommunications, recognising the need for resilience and the challenges of coordinating Black Start across a large number of parties. Proposed processes and working methods will be tested later in the project in desktop exercises involving a range of stakeholders.

The Power Engineering and Trials (PET) workstream is concerned with assessing the capability of GB distribution networks and installed DER to deliver an effective restoration service. It will identify the technical requirements that should apply on an enduring basis. This will be done through detailed analysis of the case studies and progression through multiple stages of review and testing to achieve demonstration of the Black Start from DER concept in 'live trials' on SPEN networks. Initial activities have focused on reviewing technical aspects of DER-based restoration in a number of case study locations that will support detailed analysis and testing within the project. Each case study is built around an 'anchor' resource with 'grid forming' capability, i.e. the ability to establish an independent voltage source and then energise parts of the network and other resources. Then it is intended that other types of DER, including batteries if available, join and help grow the power island, contributing to voltage and frequency control. The ultimate goal is to establish a power island with sufficient capability to re-energise parts of the transmission network and thereby accelerate wider system restoration.

The Procurement and Compliance (P&C) workstream will address the best way to deliver the concept for customers. It will explore the options and trade-offs between competitive procurement solutions and mandated elements. It uses a strategic process to develop fit for purpose commercial solutions that are open and transparent, stakeholder endorsed, and designed end-to-end with the commercial objectives of the project and workstream in mind. It will feed into business as usual activities to make changes as necessary in codes and regulations.

For an overview of the project and current progress, see the [**Distributed ReStart Progress Report – June 2020**](#)

Executive summary

This report is the second deliverable from the Organisational, Systems and Telecommunications (OST) workstream, building on the 'Organisational, Systems and Telecommunications Viability Report' published in November 2019.

During project design, the OST workstream is building on the conclusions and analysis from the viability stage to develop a preferred way forward for the organisational design and associated processes. A draft functional specification for operational telecommunications will also be delivered, alongside potential costs of meeting the functional specification and a high-level end-to-end cyber security assessment. Given the volume of work and interdependencies with the PET workstream and some external projects, our design stage outputs are split into two reports: this design stage report I and design stage report II, which will be delivered in December 2020.

In the viability stage, our focus was to identify the main challenges to delivering Distributed ReStart and consider a range of options to meet these challenges. At that stage, we presented all widely known operational telecommunications options and developed a set of organisational models to illustrate possible stakeholder roles in delivering Distributed ReStart. We avoided proposing any solutions.

Our focus for the design stage is:

- development of a preferred organisational model and associated process map, which will be taken forward and refined through desktop exercises and further stakeholder engagement
- delivery of a functional specification for operational telecommunications
 - including a review of the potential cost ranges for potential technologies
- end-to-end cyber security assessment; which will be further developed during the latter part of the project to produce a report of best practice for communications strategies and cyber-resilience for multi-party end-to-end system requirements
- assessing the requirements for information systems and the DER control interfaces required to facilitate Distributed ReStart.

The components of the work presented in this report are outlined below, together with the elements that will form design stage report II.

Key challenges

As highlighted in the viability report, both the energy and telecommunication industries are undergoing periods of rapid change, creating a significant challenge to the OST workstream. We continually monitor and engage with any important initiatives that sit alongside Distributed ReStart. These include regular meetings with the Resilience as a

Service (RaaS) NIC project team (SSEN, Costain and E.ON), who are seeking to improve network resilience in remote areas; and updates on the BEIS Distributed Generation Cybersecurity Connection Guidance, which (at the time of printing) is released September 2020.

We maintain a project-wide risk register. Key risks for OST are outlined in the RAID register provided at the end of this report.

Stakeholder engagement

Throughout this project, stakeholder engagement has delivered essential and valuable challenge to our methodologies; enhanced our understanding of the impact of Distributed ReStart on Black Start stakeholders; and provided insight into other projects and initiatives, giving the project useful learning and opportunities to feed into developments. This engagement now includes international conferences and trade associations, and will continue for the rest of the project.

Assumptions

In order to develop a coherent set of outputs, we have agreed a set of assumptions across the project:

- Inter-control centre communications protocol (ICCP) links will be available between NGESO and the DNOs.
- DER start-up procedures will not require automation. However, once started, we expect DERs to be able to accept and respond automatically to control signals if required.
- A distribution power island will be used to energise up to and including 400kV assets.
- Emergency instructions can be used for 'large' DER involved in the overall restoration process.
- Communication can be provided directly to DER to enable automation.
- Distributed ReStart should maintain a risk profile similar to the existing Black Start process.

These assumptions have been used across the design stage and underpin the:

- analysis of the options identified in the OST viability report;
- development of a preferred organisation model and associated process map; and
- identification of the operational telecommunications functional requirements to facilitate Distributed ReStart.

Distributed ReStart Zone

The concept of a Distributed ReStart Zone is integral to the process, organisational and operational telecommunications design. A DRZ contains all assets and DERs which are located within a predefined distribution network area and includes transmission network synchronisation point(s).

Collectively these assets provide a transmission level service. This service may include outward energisation or could be limited to the restoration of local energy supplies until synchronisation can be achieved. The project has identified a need to introduce a controller to overcome some technical challenges and to reduce the overall workforce burden to a manageable level.

Figure 0.1

A Distributed ReStart Zone with indicative Distributed ReStart Zone controller (DRZC) system hierarchy, significant variations exist between manufacturer designs and not all solutions use all levels of controller

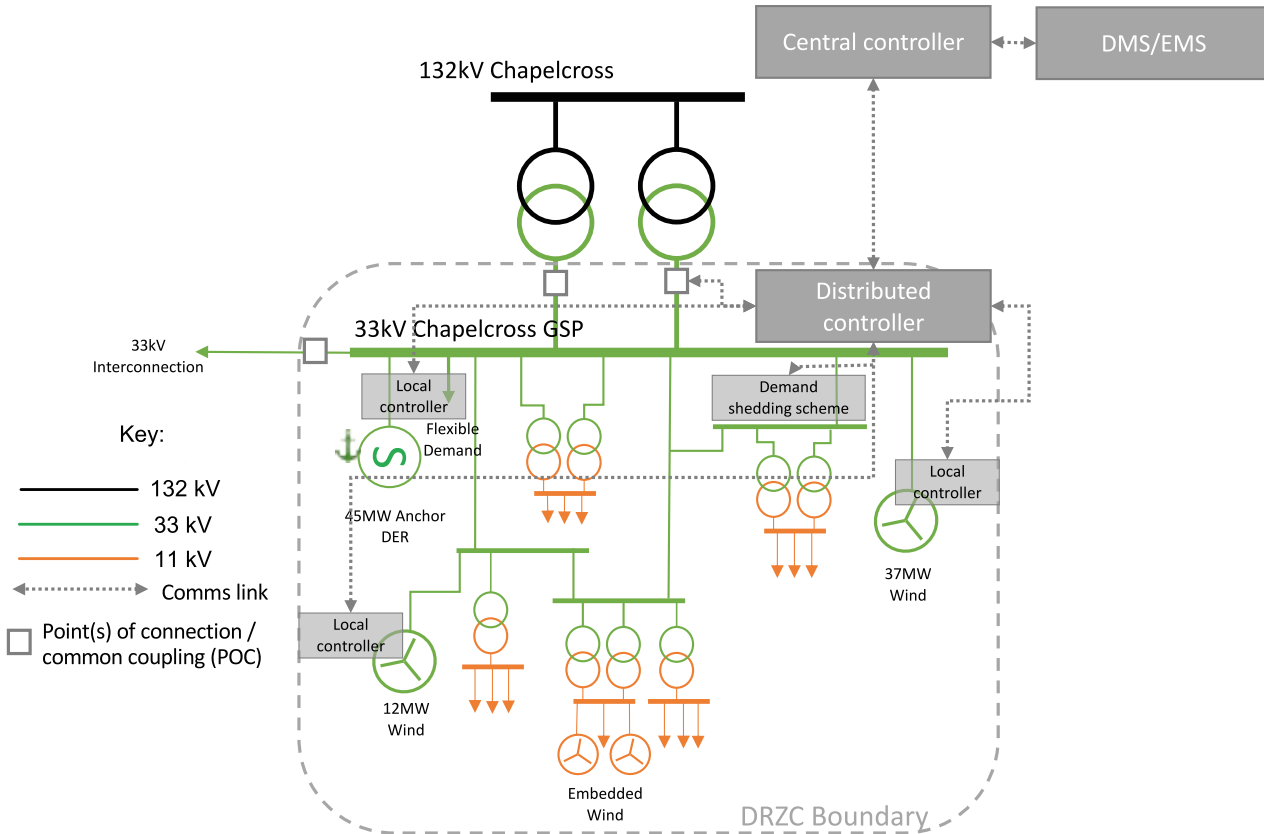

The project will deliver a functional specification for a new DRZC, which is expected to reduce the workforce burden of manual processes and take fast-acting control of network and energy resources to maintain power island stability across the Black Start stages. A number of solutions that make use of various proprietary hardware and software implementations are undergoing further development. Figure 0.1 shows the potential system hierarchy of the DRZC noting that its interface is with the distribution management system (DMS) under the central organisational model proposed in this report. Whilst DRZC designs are still under development there are some common elements to all design solutions. A DRZC will:

- provide operators with visibility of DRZ behaviour during the restoration process, including confirmation of status, monitoring of frequency and voltage stability, and power island capability to resynchronise to the transmission system

- provide operators with a view of the current DRZC progress within the restoration plan
- display the response of connected energy and network resources
- actively control distribution network actions.

Dependent upon DRZC design, the DRZC may:

- provide real-time availability monitoring of the DRZC ahead of a Black Start event
- calculate and display the export capability of the power island at the point of connection (POC).

Process design

The analysis presented in this report has been developed through stakeholder engagement and modelling of manual procedures following the organisational models set out in the viability report. From the analysis to date, feedback from industry and wider industry developments on Distribution System Operator (DSO) functions, these initial NGESO and DNO led procedures have been refined to create a single collaborative 'central model'. This central model leverages the capabilities of individual organisations and reduces the requirements for organisational change.

A plan that relies on local leadership, but with appropriate data and strategic communication with the party accountable for national restoration, achieves the greatest organisational efficiencies through minimisation of interfaces and reduction in the overall resource requirements. In addition, it allows for plans to be executed without requiring the overall strategy development in cases where there is no time-dependent requirement on transmission network availability.

Key accountabilities in the central model are distributed according to table 0.1 and are shown as a comparison to the existing process. The specific actions mapped in the process design section will be further refined and optimised through use of desktop exercises across the project's refine stage.

Table 0.1

Comparison of key accountabilities between existing Black Start and the proposed central model

Action	Responsible under current Black Start	Responsible in the proposed central model
Declare Black Start	NGESO	NGESO
Responsible for national strategy	NGESO	NGESO
Responsible for regional strategy	NGESO/Scottish TO	NGESO
Instruct start of plan	NGESO/Scottish TO	NGESO/Scottish TO, only withheld where a DRZ requires access to the transmission system to sustain supplies for an extended period
Instruct start of Anchor DER	N/A	DNO
Instruct transmission switching actions	NGESO	NGESO
Physical transmission network actions	TO	TO
Physical distribution network actions	DNO	DNO
Physical actions of contracted generation	Black Start provider (or virtual lead party)	Multiple individual providers
Instruct DRZ energisation route	N/A	DNO/Scottish TO ¹
Instruct growth option outside of DRZ boundary	N/A	NGESO
Instruct DERs within a DRZ	N/A	DNO/Scottish TO ¹
Instruct DERs outside of DRZ boundary	NGESO where Black Start provider	NGESO
Instruct non-contracted DERs (emergency instruction equivalent procedure)	NGESO through DNO (clarified through GC0143)	NGESO via DNO instruction
Manage overall distribution power island voltage and frequency	N/A	DNO is frequency leader until synchronisation with an energy resource or demand outside of the DRZ

Organisational design

Rather than propose a specific organisational structure, the project has conducted sensitivity analysis on various key factors in the management and execution of a distribution led Black Start procedure. This will enable individual companies to structure their businesses as appropriate to meet the requirements for any future contract but demonstrate the limitations or additional workforce requirements introduced through the project. The key factors considered are:

- (A) The degree of automation utilised
- (B) The complexity of each individual plan
- (C) The number of plans to be executed

Degree of automation

Even when considering a single restoration procedure, OST found that use of a Distributed ReStart Zone controller (DRZC) leads to a significant reduction in time taken

to execute a plan to the point of transmission network synchronisation. Furthermore, this leads to a lower average headcount for DNO control engineers across the duration of a restoration plan. Therefore, use of a DRZC is recommended as part of the base organisational design with a manual procedure acting as a redundant option.

Degree of complexity

A key factor that affects the complexity of each restoration procedure is the number of energy suppliers that form part of a plan. A major benefit demonstrated through the sensitivity analysis is that use of a DRZC allows participation of smaller energy suppliers by enabling more resources to contribute to a single plan. The duration and the workforce requirements are still increased due to the sequential processes, but to levels which do not require a large degree of organisational change under likely implementation models and provide capability to manage longer-term solutions which may incorporate many DER.

¹ A DRZ may span sections of 132kV network inclusive of 132kV energy resources, in Scotland this is a transmission voltage meaning that the TO function would assume overall plan responsibility from the DNO post 132kV energisation.

In addition to the number of DERs, the objective of any restoration procedure affects the complexity and hence the organisational impact. A plan which only delivers a distribution level restoration process represents a decrease in complexity. Due to DRZC functionality very little control engineer input is required to maintain stability after the plan is concluded. The analysis in this report demonstrates that local supplies could be restored very quickly if DER with short start-up times were used. This creates an opportunity to improve restoration timelines without delivering the full energisation process, enabling a greater number of plans to be delivered within a 24 hour period which would improve performance against the expected Black Start Standard metrics.

Number of plans conducted in parallel

When considering manual procedures, there is minimal operational efficiency provided by a single DNO managing multiple DRZ concurrently. More plans enacted in parallel directly require greater labour hours. Therefore, higher headcounts would be needed, or restoration times would slow.

This contrasts with a plan that includes a DRZC. In this case, whilst the numbers of switching actions increase for a DNO, energy resources do not require micro management and more than one plan can be monitored by a single control engineer. However, when a threshold is met for concurrent supervision of plans a step change is observed in the labour requirement. The number of plans started in parallel should therefore be kept below this threshold figure, which will be established through desktop exercises.

Operational telecommunications

Telecommunications requirements

Our design approach is to consider what resilience is appropriate, technically achievable and economically viable; and how we gain assurance that the required resilience is provided at all times.

Rather than dictate a technology, we are seeking a solution that is technology agnostic and applicable across GB. Therefore, development of a set of functional requirements has been central to our work. OST have used the organisational models defined in the viability stage of the project to review the communications infrastructure requirements to facilitate the processes. Multiple options exist to meet each organisational model. Extending the DNO network to the DER site or upgrading existing DNO to DER communications networks to meet Black Start functional requirements provide the most viable options.

Over the coming weeks we will fully develop our functional specification with the new information available from the DRZC initial design and requirements reports and the BEIS Distributed Generation Cybersecurity Connection Guidance.

Operational telecommunications costs

Alongside the development of functional requirements, we have been working with stakeholders to assess the potential costs of meeting a Distributed ReStart functional specification using different technologies and for different case studies (considering different terrain, existing technologies, augmentation of existing solutions and multiple party service provision).

An indicative cost review has been completed across many technologies that are considered viable. Note that the costs presented in this report reflect the price of a new installation. Where there is already embedded infrastructure that can be leveraged, the costs will be significantly different. Cost case studies are being carried out with a number of DNOs and more cost information will form part of the design stage report II.

Cyber security

A high-level end-to-end assessment of the cyber security risks associated with the telecommunications options and control models being considered as part of Distributed ReStart has been completed.

If unmitigated, cyber security risks are likely to increase over time driven by technological innovation, the inclusion of new generation sources and accelerated cyber threats. Appropriate and proportionate mitigations will be required to manage the risk.

Work will continue in this area and updates will be provided in design stage report II, with the end goal being a report of best practice for communications strategies and cyber-resilience for multi-party end-to-end systems required to deliver Black Start from DER.

Systems and DER control interface

A detailed analysis of the systems and applications required for the central model has commenced and will be presented in design stage report II. In terms of physical control and asset management, the central model aligns closely with the automated DNO led model so this will form the basis of this work.

The DRZC design will also feed into this work should further requirements from the DRZC design prompt a requirement for additional new applications/systems or requirement for a new functionality.

The requirements to facilitate the collaborative central model will reflect those identified as affected under the DNO automated control model due to the anticipated use of a Distributed ReStart Zone controller (DRZC) which is directly interacted with by the DNO. These key systems are shown in table 0.2.

Table 0.2

Key systems for Distributed ReStart

System	Location	Current state/Notes
Integrated Energy Management System (IEMS)	NGESO, TSO	This is currently in place
Distribution Energy Management System (DMS)	DNOs	This is currently in place
DRZ controller	DNOs or NGESO	This will depend on the design specifications
ICCP	Connecting NGESO IEMS and DNOs DMS	This is partially deployed. This will need to be deployed to all DNOs
Frequency measurement devices	DNOs	This requires deployment to all DNOs and to be incorporated as part of the micro-grid solution

As more certainty on the DRZC design is attained, alterations to these systems can be proposed. Gap analysis will be presented in the design phase report II.

Telecommunications next steps

A detailed analysis of the systems and applications required for the central model has commenced and will be presented in design stage report II. In terms of physical control and asset management, the central model aligns closely with the automated DNO led model so this forms the basis of this work.

The DRZC design will also feed into this work if further requirements from the DRZC design prompt a requirement for additional new applications/systems or requirement for a new functionality.

Report structure

As outlined below, the design stage outputs are split between this report and a second report to be delivered towards the end of 2020.

The work will continue into 2021, with the detail of the central model being developed alongside the operational telecommunications functional specification. Close collaboration across the project workstreams will be maintained to provide a coherent and complete set of proposals for Distributed ReStart. External engagement will be increased, specifically with trade organisations and DER, as we move into delivering desktop exercises and finalising our proposals.

Design stage I (this report)

- Methodology for development of the operational telecommunications functional specification.
- Initial cost estimates and methodology for development of cost case studies.
- Initial end-to-end cyber-resilience methodology and mitigation assessment.
- Systems considered essential to Distributed ReStart.
- An introduction to the DER control interface.

Design stage II (due end of 2020)

- Draft functional specification for operational telecommunications.
- Outputs from the OST cost case studies.
- Further end-to-end cyber-resilience analysis.
- Analysis of the systems' functionality considered essential to Distributed ReStart.
- Initial gap analysis of the current and required DER control interface.

Figure 0.2

Project milestone (10) – timeline

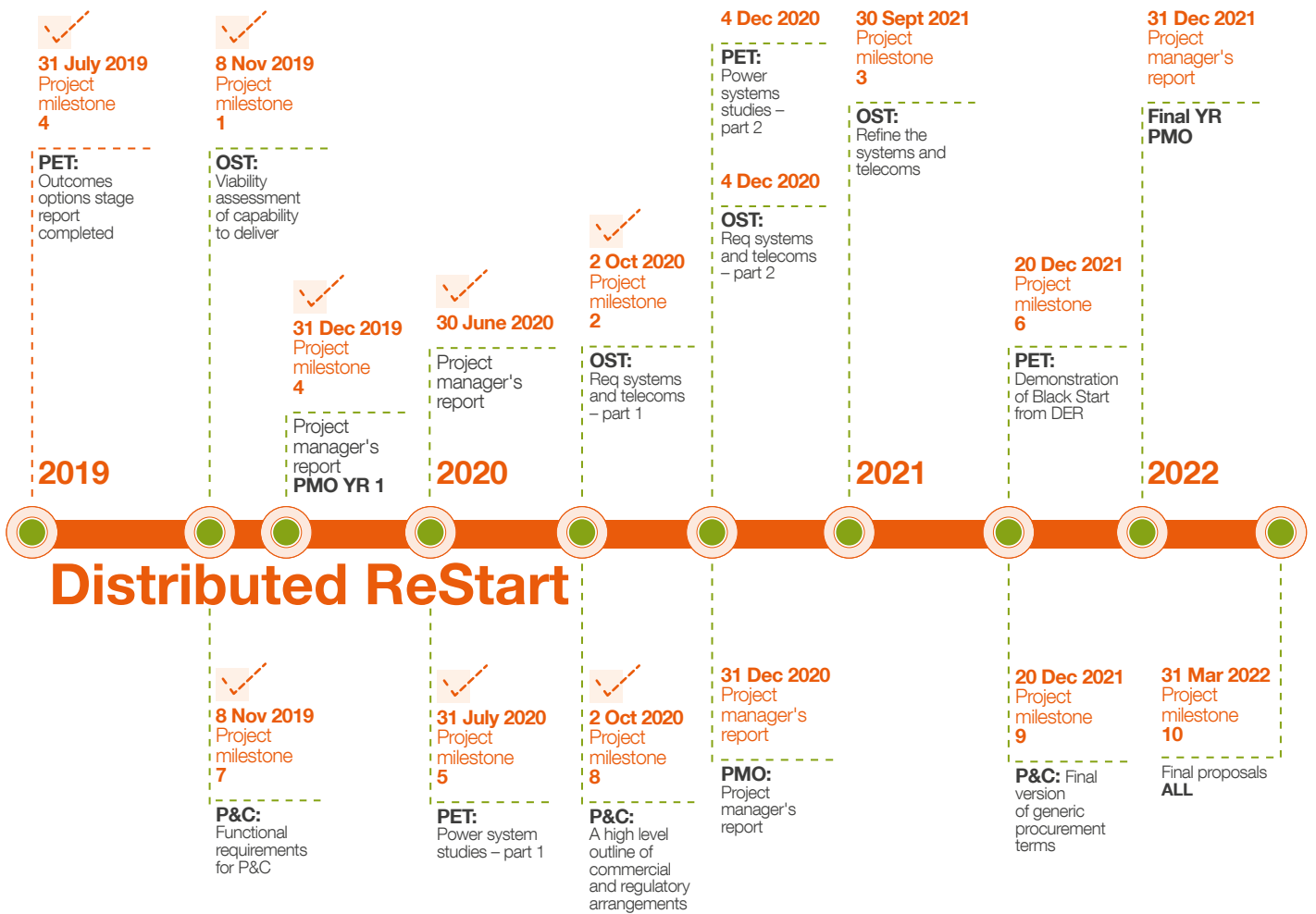

Distributed ReStart



Introduction

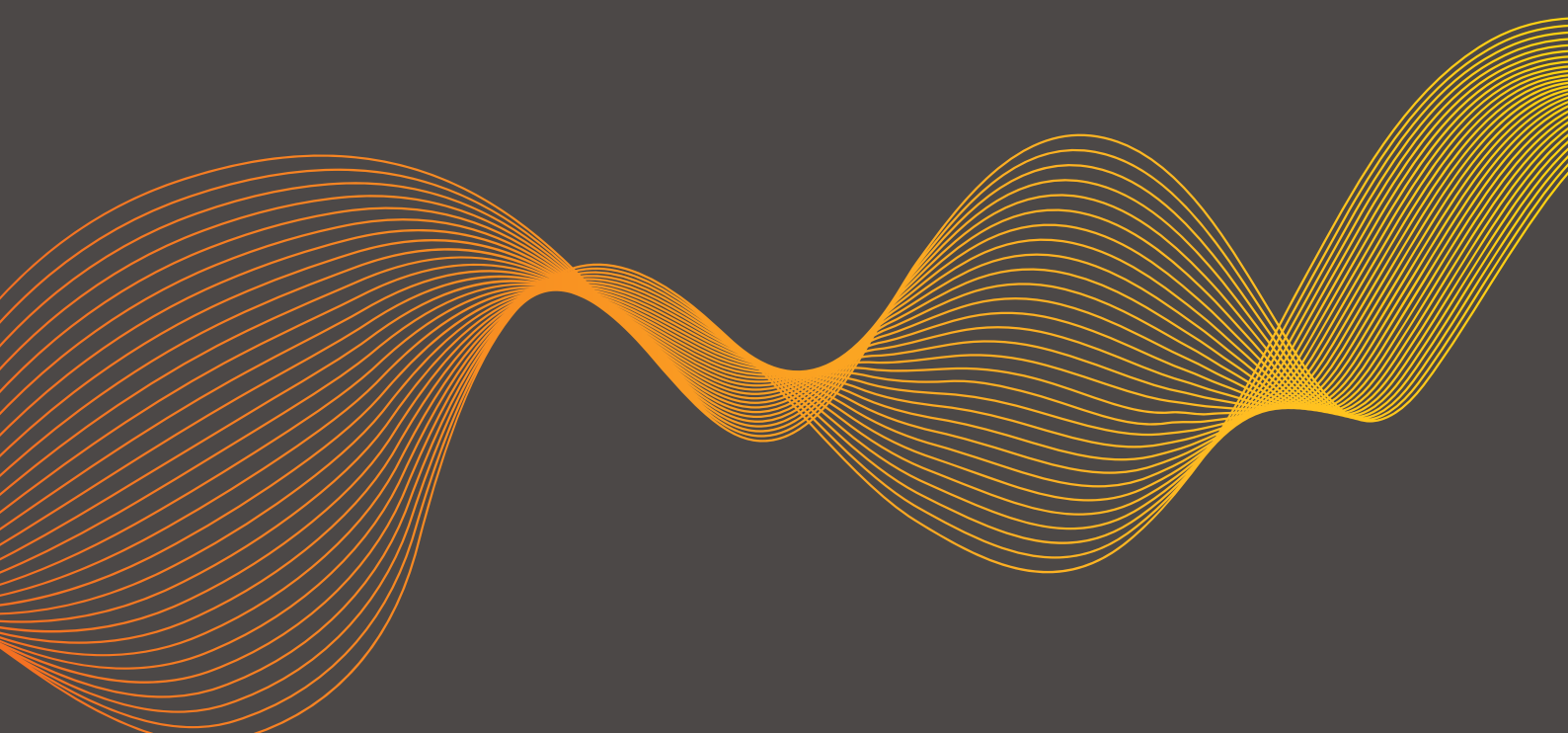



1.1 This report

This report builds on the **‘Organisational, System and Telecommunications Viability Report’**, delivered in November 2019. Our focus for the viability report was to identify the main challenges to delivering Distributed ReStart and consider a range of options to meet these challenges. At that stage we presented all widely known operational telecommunications options and developed a set of organisational models to illustrate possible stakeholder roles in delivering Distributed ReStart. We avoided proposing any solutions.

In the project design stage, we have built on the conclusions and analysis from our viability stage to refine our thinking and develop a preferred way forward for the organisational design; functional requirements for operational telecommunications; a technology cost review; and an end-to-end cyber security assessment. Our design stage outputs are split into two reports. This design stage report I and design stage report II, which will be delivered in December 2020.

1.2 Report structure

In this report we consider the key challenges that arise both as a direct result of Distributed ReStart and those that are a result of external changes or initiatives. We illustrate how we are addressing those challenges, through industry engagement and through the development of clear methodologies and assumptions that form the basis of our design stage.

Active stakeholder engagement has been an essential part of our project and this continues, with the breadth of stakeholders involved continually increasing. A summary of this engagement can be found in section 3.

Our assumptions upon which the design stage work is based are set out in section 4, with the concept of the DRZ set out in section 5. This is used across the OST analysis.

Sections 7 to 11 provide a summary of the detailed analysis that has been conducted on process design and organisational structures during the design stage. We have worked closely with the other workstreams and stakeholders to assess the impact of the four organisational models developed in the viability stage. Process maps and structures have been developed and we introduce our preferred model for the early stages of Distributed ReStart implementation.

In sections 12 to 17 we consider operational telecommunications requirements and explain the ongoing work in this area. Sections 12 and 13 describe our general approach and provide high level summaries of the existing ways of working and technologies being used. The methodologies used for developing functional requirements and for assessing the potential costs of meeting these requirements are described in sections 14 and 15. The outputs from these exercises will be presented in the Design Stage II report towards the end of 2020. An assessment of the end-to-end cyber security is included in section 16 and our next steps are discussed in section 17.

The required systems aligned to the four organisational models are considered in section 18 and the DER control interface is discussed in section 20. The final sections of the report summarise our conclusions so far and the next steps to take us to the design stage report II and then into the refine stage of the project.

Key risks for OST are outlined in the RAID register provided at the end of this report.

1.3 Content in design stage reports I and II

In summary, the content of the two design stage reports is as follows.

1.3.1 Design stage I (current report)

- Methodology for development of the functional specification.
- Initial cost estimates and methodology for development of cost case studies.
- Initial end-to-end cyber-resilience assessment methodology and mitigation.
- Systems considered essential to Distributed ReStart.
- An introduction to the DER control interface.

1.3.2 Design stage II (due end of 2020)

- Draft functional specification.
- Outputs from the OST cost case studies.
- Further end-to-end cyber-resilience analysis.
- Analysis of the systems’ functionality considered essential to Distributed ReStart.
- An introduction to the DER control interface.
- Initial gap analysis of the current and required DER control interface.



Multiple industry initiatives are happening in parallel with Distributed ReStart and provide us with a number of challenges to overcome.

2.1 Introduction

In the viability report we identified a number of key challenges to the OST work:

- Black Start stakeholders;
- changing environment; and
- telecommunications resilience.

The challenge of developing a coordinated approach to Black Start with the introduction of a significant number

of stakeholders and an increase in roles and stakeholder types is considered throughout this report, in both the organisational requirements and the need for consistently robust, resilient telecommunications with low cyber security risk. Our decision to develop a functional specification for operational telecommunications allows Black Start participants flexibility in the technology used to meet the needs of Distributed ReStart.

Alongside these OST-specific challenges, Distributed ReStart has identified a number of project-wide challenges, noted below in table 2.1.

Table 2.1

Distributed ReStart challenges

There is significant change across the electricity industry as the DSO model develops and decentralisation of generation continues. How can the project ensure our proposed solutions are aligned with future changes?

Most DER were never intended to provide Black Start capabilities. Is it practical to retrofit the capability or will this service have to be “built in” to new DER?

The distribution networks were not designed with bottom-up restoration in mind and some investment will be necessary. How is this best achieved in the context of the RIIO price control process and other funding options?

Will commercial incentives alone be enough to ensure sufficient volume of DER with Black Start capability, or should codes be revised to make some capability mandatory for new connections?

DER-based Black Start places new responsibilities on multiple organisations. Will training and organisational preparation take longer, and ultimately cost more, than technical changes to DER and networks?

DNO flexibility markets are starting to emerge but have so far demonstrated relatively low liquidity. How can the project promote liquidity and competition for this more complex service?

Splitting out individual services and procurement over different timescales could potentially enable more technologies to participate but also increase service search costs. How should the project balance these different cost drivers?

Decarbonisation, decentralisation and digitalisation are affecting electricity networks across the whole world and others are reviewing their approaches to restoration and the role of DER. How does the project make best use of methods and approaches developed elsewhere to maximise consumer benefit here in GB?

2.2 Changing environment

As highlighted in the viability report, both the energy and telecommunication industries are undergoing periods of rapid change. We have therefore continually monitored and engaged with any important initiatives that sit alongside

Distributed ReStart. Table 2.2 provides an update to the relevant projects, consultations and activities that we have been monitoring since the outset of Distributed ReStart. Note that a number of cyber security related activities have been delayed due to the impact of COVID-19 on the resources needed to execute these initiatives.

Table 2.2

Ongoing projects impacting on the organisations, systems and telecommunications for Distributed ReStart

Type	Timing	Title	Parties	Description	Deliverables/Milestones
Project	2020	Distributed Generation Cybersecurity Connection Guidance	BEIS	A landscape review of non-domestic distributed generation in GB, including but not limited to the capacity, location and equipment type of generation resources currently in use as well as a likely future roadmap for this area as energy assets continue to become more decentralised, in consultation with the Distribution Network Operators and policy teams at BEIS.	<p>At the time of going to print, publication of the Distributed Generation Cybersecurity Connection Guidance is anticipated for end of September 2020.</p> <p>Publication is expected to include a press release and invitation to a public webinar to introduce and explain the guidance.</p> <p>This will be followed by a public consultation 6/9 months after the date of publication to address feedback from the users of the guidance and use these to inform the development of later versions of the guidance.</p>
Legislation/codes	In force 12/18, implemented by 12/19	European Emergency Restoration Network Code (NCER)	NGESO, DNOs, TOs, SGUs	<p>NCER sits above UK codes. It requires a System Defence Plan (SDP) and a System Restoration Plan (SRP) to be in place. These plans sit in between the NCER and the Grid Code etc.</p> <p>NCER requires resilience of a minimum 24 hours for systems and telecommunications for TOs, DNOs and significant grid users (SGU). (NGESO definition for SGU is anyone with a CUSC contract).</p>	Parts of NCER are in force and implemented. Parts relating to telecommunications have a later implementation date and are currently being progressed (NCER Stage 2)
Legislation/codes	?	System Restoration Plan (SRP) and System Defence Plan (SDP)	NGESO, DNOs, TOs, SGUs	<p>System Restoration Plan (SRP) and System Defence Plan (SDP) conform to NCER and impacts DSOs, TSOs and SGUs.</p> <p>See https://www.nationalgrideso.com/codes/european-network-codes/meetings/emergency-and-restoration-amended-market-suspension-proposals</p> <p>SRP defines technical and organisational measures for restoration.</p> <p>SDP enforces assurance and compliance testing for TSOs, DSOs and other SGUs.</p>	<p>NGESO proposals (in SDP and SRP are with Ofgem for approval).</p> <p>Note: Electrical Standard update for control telephony, EDL/EDT; test plan and procedures to be consulted on.</p>

Type	Timing	Title	Parties	Description	Deliverables/Milestones
Procurement	Ongoing	BAU tender rounds	Potential Black Start participants, NGENSO	Historically, Black Start services have been purchased via bilateral procurement. These are now moving onto competitive procurement, providing opportunities for different technologies increasing economic and efficient delivery.	<p>South West and Midlands tender:</p> <ul style="list-style-type: none"> Launched in December 2018; F2 report submission by tender participants: July 2020; Contract award: October 2020; Service commencement: July 2022 with the option to start sooner (up to 9 months). <p>Scotland, North East and North West tender:</p> <ul style="list-style-type: none"> Launched in August 2019; F2 report submission by tender participants: January 2021; Contract award: March 2021; Service commencement: April 2022 with the option to start sooner (up to 6 months).
Industry groups	Ongoing	E3C and associated groups	Industry stakeholders	ETG/BSTG/CTG/GTG – electricity, Black Start, comms and gas task groups.	<p>E3C workplan is being reworked due to the impact of COVID-19. The focus is expected to be on:</p> <ul style="list-style-type: none"> supply chain cyber security ‘exercising’ (roles, responsibilities following an incident).
ENA facilitated industry groups – Strategic Telecommunications Group	Ongoing	Strategic Telecommunications Group (ENSTG)	ENA facilitated, includes DNOs, JRC, NGENSO	<p>ENASTG provides a focus for liaison, co-ordination and information in areas of mutual interest to ENA member companies.</p> <ul style="list-style-type: none"> It promotes the interests, growth, good standing and competitiveness of the UK energy networks industry’s operational telecommunications and IT services in the UK and overseas. It provides a forum for discussion among company members and others of Telecom and IT issues and to pass informed opinion on these matters to Ofgem, Ofcom, government departments, and other institutions in the UK and the European Union. 	Ongoing. Outputs anticipated in the coming months include an Operational Telecommunications Standard for Connected Distributed Generation and Storage.
ENA facilitated industry groups	Ongoing	ENA Open Networks project	ENA facilitated, includes DNOs, NGENSO	<p>Ofgem/BEIS supported programme looking to develop DSO functions and activities.</p> <p>Workstream WS1B is the main contact point for OST.</p>	<p>Has annual published work programme containing deliverables for five workstreams; Flexibility Services, Whole Electricity System Planning and Data, Customer Information, DSO Transition and Whole Energy Systems.</p> <p>Workstream WS1B has provided information and feedback to Distributed ReStart.</p>
ENA facilitated industry groups	Ongoing	ENA Cyber Security Task Group	ENA members	Advise ENA with regard to cyber security issues affecting the UK energy sector.	<p>Carry out benchmarking.</p> <p>Produce guidance/standards as required.</p>
Industry group	Ongoing	E3CC	E3C members, BEIS, NCSC, Ofgem (associate)	<p>Cyber Security Task Group. Risk Assessment and Strategic Programme for Cyber Security in the Energy Sector.</p> <p>DER is on the risk list.</p> <p>Some renewables are now partaking in E3CC discussions.</p>	<p>Energy Sector Risk Assessments. Producing and driving strategic programme of work, some discrete projects and supplier engagement. Implementation of govt regulations/standards etc.</p> <p>A risk subgroup has now been set up to focus on this area.</p>
Black Start training	Ongoing	BAU Black Start workshops	NGESO, TOs, DNOs	NGESO led workshops.	Increase visibility of restoration plans. Opportunity to practise restoration process and communication.

Type	Timing	Title	Parties	Description	Deliverables/Milestones
Black Start publications	Ongoing Latest version of Black Start strategy (3rd) issued 8/19	includes: Black Start strategy	NGESO	<p>The Black Start Standard outlines achievements and NGESO aims:</p> <ul style="list-style-type: none"> • Restoration timescales: 60% demand in 24hrs – This translates into number of providers required • Restoration approach – Skeleton • Probabilistic model • Technical requirements and its evolution with changing generation landscape • Combined services • Short, medium and long-term strategy • Cost components: availability, warming, CAPEX, testing, feasibility studies • 2019 also includes a summary of what was achieved in various areas (as stated in 2018 publication). <p>Publications found at: https://www.nationalgrideso.com/black-start</p>	Annual publication.
Legislation/codes	ASAP	Black Start Standard	BEIS, Black Start Stakeholders	<p>BEIS are proposing a Black Start Standard from autumn 2020, but yet to confirm.</p> <ul style="list-style-type: none"> • Implementation of the Standard requires changes in DNO infrastructure – estimated cost already submitted to the BSTG. • Assurance framework being trialled and developed to ensure the Standard can be met. • Impact on non-Black Start power stations being investigated. • NGESO implementing the Network Code Emergency and Restoration through a series of code changes. • Introduces requirement on DNO around resilience and monitoring. 	Black Start Standard.
Ofgem Distribution System Operation	2019–2020	DSO Position Paper	Ofgem	Ofgem position paper setting out their proposed approach and strategic outcomes for DSO.	Agreed industry approach to DSO including treatment of DNOs and contestable services, key enablers, and development of co-ordinated flexibility markets.
Ofgem RIIO-ED2	2019–2023	Open letter consultation on approach to setting the next electricity distribution price control	Ofgem	Open letter consultation setting out Ofgem proposals for RIIO-ED2 price control (running 2023-2028).	RIIO-ED2 price control outcomes for electricity DNOs in period 2023-2028.
Project	2020–2024	Resilience as a Service (RaaS)	SSEN, Costain E.ON	RaaS is a Network Innovation Competition funded project which seeks to improve network resilience in remote areas. The aim is to develop and trial a system which can swiftly, automatically, restore supply to customers in the event of a power outage, using services procured from a third party owned battery energy storage system (BESS) together with local Distributed Energy Resources (DER).	<p>The first stage of the project focuses on-site selection, system design for the chosen trial site, and refinement of the business case for RaaS. This stage will validate whether the concept is technically feasible and financially viable, to inform a decision during 2021 on whether to proceed with the deployment and operation of a RaaS system at the chosen site for a trial period of up to two years.</p> <p>A number of suitable primary substations (33 kV to 11 kV) have been shortlisted for site surveys to identify the site to be taken forward to detailed design stage.</p>

One of the key documents with which we need to align is the DER Cyber Security Connection Guidance. This document is now complete and, at the time of going to print, was due to be published by BEIS in September. This guidance, together with the ENASTG Operational Telecommunications Standard for Connected Distributed Generation and Storage (which is due out in the coming months) is a key piece of guidance with which OST will seek to align any functional specification for Distributed ReStart.

2.2.1 DER Cyber Security Connection guidance

Whilst not currently meeting the 'essential service' criteria laid out in the NIS (Network and Information Systems) regulations, the growth of DER usage is such that it is now becoming increasingly important to the UK's energy supply. However, from a cyber security point of view, there is no real guidance or standard to ensure connected assets are securely installed, connected and managed.

Working closely with the Energy Emergencies Executive Cyber Security Task Group (E3CC) and the Energy Networks Association (ENA), BEIS identified the need to address cyber security controls across the increasing amount of DER connected to distribution networks.

This guidance is a result of collaboration between BEIS, ENA, DNOs, National Cyber Security Centre (NCSC) and operators who have provided industry insight, shared challenges and made suggestions to improve DER cyber security across the industry.

The guidelines have been closely aligned to the four objectives and fourteen principles from the NCSC Cyber Assessment Framework (CAF), but broken down into more modular components that are better suited to smaller organisations.

Adoption of these cyber security connection guidelines will support delivery of end-to-end security for DER, at an industry accepted level. It will also enable our DNOs and operators to effectively and consistently implement an industry baseline for cyber security when connecting new DER assets to the distribution networks.

In summary this guidance aims to:

- 1.** promote cyber security throughout the design and implementation of new DER projects
- 2.** provide a consistent approach to cyber security for DER connections across the UK
- 3.** provide a baseline level of security that is required for new DER connections
- 4.** enable BEIS and the ENA to address short-term and long-term threats and promote standardisation
- 5.** provide cyber security guidelines that are flexible enough to apply to any DER, regardless of size or location
- 6.** provide guidance to assist generators, aggregators and network operators alike
- 7.** provide guidance that may influence technology providers to improve security for their devices out of the box.

Engagement with some of the other key initiatives listed above are described in section 3, industry engagement.



Distributed ReStart continues to work with the wider industry at every opportunity, bringing diverse expertise into the project process.

3.1 General approach

To scrutinise the methodologies and outputs across the Distributed ReStart project, we have established a stakeholder advisory panel to provide industry views. Members include a range of industry experts such as academics, BEIS, Citizens Advice, Energy Systems Catapult, Cornwall Insights and the ENA, and their feedback has been extremely valuable.

To develop both our operational telecommunications functional requirements, and our process and structure options, we have used a set of stakeholder engagement packs to provide draft options and associated background information to engage trade groups, associations and individual stakeholders. Some details of our industry engagement is set out below:

3.1.1 Black Start participants (and potential participants)

Significant investment has been made in gathering views from current and potential Distributed ReStart participants (DNOs, TOs, DER) due to their pivotal role in any future Black Start process. We will continue to engage through workshops, bilateral meetings, industry groups and other project initiatives.

As SP Energy Networks (SPEN) holds both transmission and distribution network licences, we have full integration of a TO within the project team. In addition, we have engaged with the other onshore TOs across GB to solicit their input. In addition to the project-wide activities, engagement to date has included both bilateral dialogue and industry groups, such as the ENA Open Networks and Strategic Telecommunications Groups. We will maintain active dialogue with potential Distributed ReStart participants throughout the duration of the project.

3.1.2 Energy Network Association (ENA) groups

ENA Strategic Telecommunications Group (ENASTG)

We continue to attend the ENASTG. This group is facilitated by the ENA and provides a focus for discussion and coordination of its DNO, TO and NGESO members and the Joint Radio Company (JRC) to identify and share how operational telecommunications are transforming and what enhanced capability is needed to address current and future challenges.

Through sharing our thinking on operational telecommunications function requirements and the potential costs of delivering the required infrastructure and services with the STG we have gained valuable feedback. Terms of reference can be found at: <http://www.energynetworks.org/electricity/engineering/energy-telecommunications.html>

ENA Open Networks WS1B

Through sharing our thinking on process and organisational design we have been able to discuss and incorporate key issues with wider Distribution System Operator initiatives.

Our engagement with WS1B (whole electricity system planning and Transmission-Distribution Data Exchange) of the ENA Open Networks project has been used to gain representative views from its DNO, TO and NGESO members on the allocation of responsibility for specific actions and the data exchange interfaces introduced through process and organisational models.

3.1.3 Related projects

RaaS project

RaaS is a Network Innovation Competition funded project seeking to improve network resilience in remote areas. The aim is to develop and trial a system which can swiftly, automatically, restore supply to customers in the event of a power outage, using services procured from a third party owned battery energy storage system together with local DER.

As well as demonstrating the technical concept, the project will develop the commercial framework for RaaS, evaluating the financial case from a DNO perspective and assessing the investment case for RaaS service providers and options for revenue stacking in other flexibility services markets. As such, this is an important project with which Distributed ReStart is sharing knowledge. RaaS is now a member of the project stakeholder advisory panel.

Imperial College and Smart Power Networks engagement:

Regular calls on operational telecommunications and cyber security are held with Imperial College and Smart Power Networks to exchange knowledge between project teams.

3.1.4 Regulators (Ofgem and Ofcom):

We continue to have fruitful discussions with Ofgem and Ofcom. In particular, Ofgem have provided useful comments and feedback on our preferred model, the central model, which is discussed in the organisations and processes sections of this report.

3.1.5 Joint Radio Company (JRC):

We have gained valuable feedback from JRC bilaterally and via the ENSTG, particularly with regard to operational telecommunications details and costs.

3.1.6 Suppliers, manufacturers and service providers, trade associations:

During the design stage, we have made significant progress in engaging trade organisations, for examples:

- Europe Utility Technology Council (EUTC) (with Distributed ReStart being in the EUTC April newsletter and a presentation being given at 'The connectivity challenge for future energy networks' held in collaboration with techUK on July 29, 2020). The EUTC has been invaluable in providing engagement on an international level.
- GSMA (Global System for Mobile Communication Association) represents the interests of mobile operators worldwide.
- E3CC (UK Cyber Security Task Group, Distributed ReStart is presenting September and November 2020).
- BEAMA (The UK trade association for manufacturers and providers of energy infrastructure technologies and systems).

3.1.7 Interested stakeholders:

Over the last 18 months of the project, we have continued to maintain a high level of stakeholder engagement across industry experts, professionals, academia and the media. We have integrated ourselves into other key projects and initiatives, e.g. Strategic Telecommunications Group, Open Networks, RaaS and maintained our engagement with BEIS, Ofgem and ENA.

Distributed ReStart presented at the Operational Forum, and exhibited at Utility Week Live, Power Responsive conference, LCNl and the NGESO Customer Connections seminars to reach out to broader industry stakeholders. We will continue to interact with interested parties through conferences and projects events over the next 18 months.

The project has used social media extensively to promote project events, project reports and webinars to help stakeholders understand the reports and discuss the direction of travel, all the above is available on the project subsite link: <https://www.nationalgrideso.com/innovation/projects/distributed-restart>

In addition to the OST-specific activities listed above, global interactions include:

- GO 19, through senior managers within the wider project;
- project representation on a relevant CIGRE working group;
- submission of a paper in early 2020 to CIRED.

Distributed ReStart has an active distribution list of over 720 registered interested parties and use this as a channel to engage with people globally through 'Thought Leadership' articles, sharing pertinent project information and news, webinars discussing specific project deliverables or challenges and to promote attendance at specific industry events.

We meet with the stakeholder advisory panel regularly to discuss progress, design assumptions, industry changes and impacts to Distributed ReStart.

Examples of industry events attended during 2020 are shown in table 3.1.

Table 3.1

General engagement activities

Event	Value unlocked
Distributed ReStart webinar on OST and P&C outputs – 8 January 2020	Knowledge share with over 100 interested people specifically sharing key outputs from the viability stage publications.
Distributed ReStart conference 2020 – 30 January 2020	A conference focused on project progress and wider industry concerns related to the project. Including presentations from the steering committee and multiple guest speakers.
Speaker at Future Networks – 25 February 2020	Engagement with broad industry stakeholders specifically interested in the future of energy networks.
Distributed ReStart virtual event – July 2020	Engagement with a broad audience interested in Black Start, disseminating design stage learnings through detailed and interactive presentations spread across 3 days.

The project has taken part in extensive targeted industry consultation, inclusive of membership of working groups and hosting workshops. This allows direct input to project deliverables, drawing on knowledge of subject matter experts, inclusive of rigorous challenge.

Table 3.2

Table of specific industry consultation activities

Event	Value unlocked
EPRI workshop – 23 June 2020	International knowledge share through the Electric Power Research Institution.
CIREN – 22–23 September 2020	Key project learnings are included in the CIGRE and CIREN 2020 conferences, providing a further channel for expert review.
CIGRE – 24 August – 3 September 2020	
E3CC conference – 19 November 2020	Attendance at conference, due to present on 19 November 2020 (pending further COVID-19 developments)
Utility Week Line Online – 24–26 November 2020	Engagement with broad industry stakeholders – 10,000 members

<https://www.nationalgrideso.com/innovation/projects/distributed-restart>

Figure 3.1

Output of the Distributed ReStart conference with regards to the overall approach to stakeholder engagement





The general approach and assumptions specific to Operational, Systems and Telecommunications are described below.

4.1 Introduction

During the design stage we have examined the available options for future processes, roles, systems and telecommunications in detail. Whilst conducting these assessments, we have developed a set of assumptions to maintain a consistent approach across OST and the project.

As a project, Distributed ReStart maintains a project-wide set of assumptions. Assumptions that are OST-specific and have been developed as part of the design stage are noted here to provide a basis for the analysis in the following sections. These sit alongside the technical assumptions made by the PET workstream, and the regulatory and procurement assumptions made by the P&C workstream in the associated design stage reports on <https://www.nationalgrideso.com/innovation/projects/distributed-restart>

Assumptions from the OST viability report, such as the need for clarity and simplicity in all processes and technologies, remain valid.

4.2 OST design stage assumptions

4.2.1 Assumption 1

ICCP links will be available between NGENSO and the DNO

Background:

- Feedback from the DNOs through Open Networks has confirmed that all DNOs intend to install an ICCP link with NGENSO within project timelines.
- OST will monitor any developments on ICCP links and their implementation.

4.2.2 Assumption 2:

DER start-up procedures are not automated by the DRZC

- Anchor generators: we assume that start-up process will not be an automated procedure. However, we do expect an automatic response to setpoint signals after start-up.
- DERs (both manned and unmanned sites): Start-up procedures need not be automated, i.e. they may require human intervention. However, it is assumed that once a DER has started, it will accept control signals and respond automatically if required.

Background:

- Active network management (ANM) Distributed Energy Resources Management System (DERMS) schemes already exist and already apply automation, so this isn't a novel issue and we expect DERs to accept this control interface.

4.2.3 Assumption 3:

The project goal remains transmission energisation (up to and including 400kV)

However, there are five potential end goals considered feasible from a DRZ restoration:

- A. Supply of distribution site supplies only, providing an alternative for investment in additional resilience equipment such as diesel generators and batteries.
- B. Supply of transmission and distribution site supplies, providing an alternative for investment in additional resilience equipment.
- C. Supply of local demand within the DRZ only, providing an option to improve demand restoration timescales and better serve customers but providing no contribution to outward transmission level energisation.
- D. Supply of local demand within the DRZ and restoration of transmission site supplies, providing an alternative for investment in local resilience equipment.
- E. The power island acts as a virtual Black Start provider, providing functionality similar to an existing Black Start provider.

Background:

- Each end goal could require different organisational/process structures, which are being considered by OST during the design stage.
- PET workstream findings to facilitate energisation up to 400kV are that resources are required at 132kV or 275kV to provide sufficient fault infeed current for detection by transmission CTs [1]. These resources may be specific fault infeed sources, not necessarily synchronous generation.

4.2.4 Assumption 4:

Emergency instructions can be used for DER considered 'large' as part of the overall DRZ restoration process.

Background:

- DNOs consulted were comfortable with emergency instructions being required to facilitate Distributed ReStart.
- DNOs have the capability (clarified through the GC0143) to enact emergency instruction to disconnect distribution connected assets.
- Emergency instructions can be applied to any generator that is a connection and use of system code (CUSC) signatory. All DERs currently considered to be 'large' generators are required to sign the CUSC and therefore adhere to the Grid Code. However, the current definition of 'large' varies between TO areas, many sub 50MW generators in England and Wales will not be considered 'large'. This is a subject that is currently being reviewed and that the project will be staying close to via the P&C workstream.
- P&C are reviewing the suitability of emergency instruction and commercial structures through their codes review.

4.2.5 Assumption 5:

Communications can be provided directly to the DER to enable automation

Action for project: OST to engage further with DER to assess willingness of DER to implement.

Background:

- The control point of unmanned DERs is typically at a remote terminal unit (RTU) at/alongside the DER site, ANM schemes can directly interface with this RTU.
- It can be more challenging to provide the required communications to manned DERs as the control point is often at a remote-control room with telecommunications between this point and the DER.
- OST will need to ensure telecommunications specifications cover requirements between the control interface and the asset, where these are located separately.

4.2.6 Assumption 6:

Our assumption is that we should be working to a similar level of risk as the current Black Start process, for example:

- The project will not add extra requirements to decrease the risk in Distributed ReStart if this introduces additional cost.
- Outputs that can reduce the risk without additional complexity or cost should be considered.

5. Distributed ReStart Zone



Black Start from DER will rely on the effective coordination of both multiple energy resources and a distribution network to provide a service which can contribute to the restoration of demand, generation and networks in the unlikely event of a partial or total blackout. The collective term used by the project for these power islands is Distributed ReStart Zone (DRZ).

A DRZ contains all assets and DERs which are located within a predefined distribution network area and includes transmission network synchronisation point(s), this is depicted in figure 5.1. Collectively, these assets provide a transmission level service which could include outward energisation or may only restore local energy supplies until synchronisation can be achieved.

Within a Distributed ReStart Zone, there is a need for a control system that is capable of fast control not possible through the existing distribution management system (DMS). This Distributed ReStart Zone controller (DRZC) is discussed in section 10 and provides operational support reducing workforce requirements (see section 11) and providing technical support against power systems requirements (see PET design stage report I).

This will enable delivery against the expected Black Start Standard requirements on demand restoration timelines and provide an alternative to conventional transmission connected resources for Black Start capability, in turn reducing costs and increasing security.

Figure 5.1

Diagram showing a DRZ across all voltage levels, note that this is illustrative only and has been altered from the actual Chapelcross case study to encompass expected process

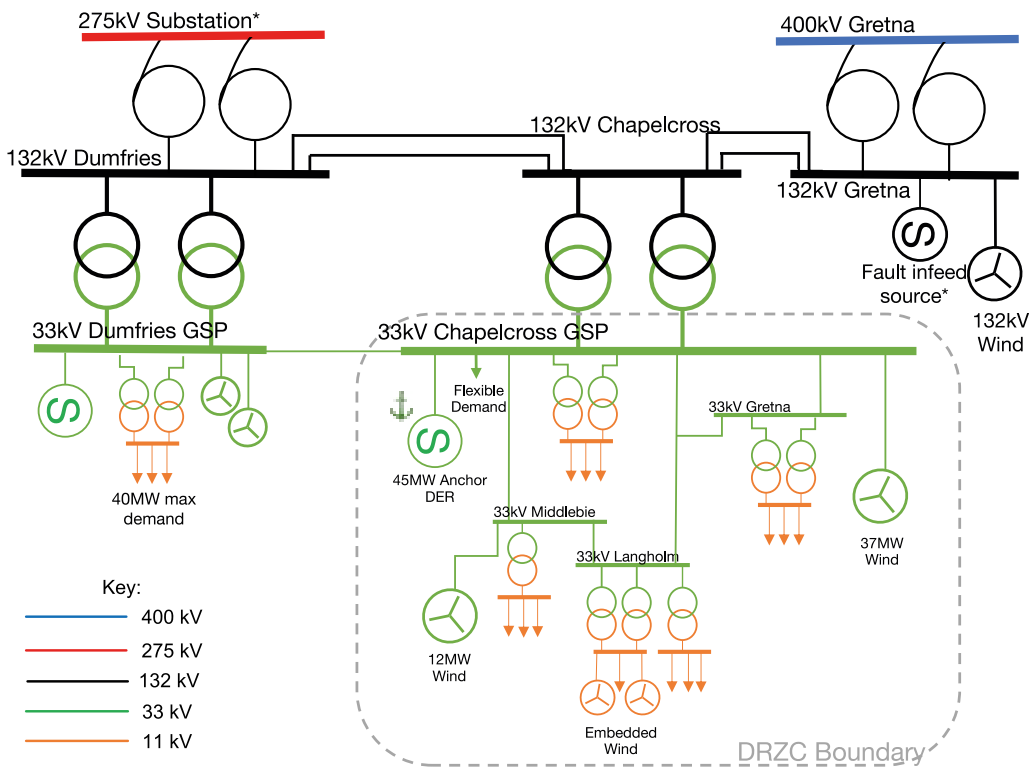

* For illustrative purposes only the chapelcross network area has been altered

Distributed ReStart



Organisations and processes

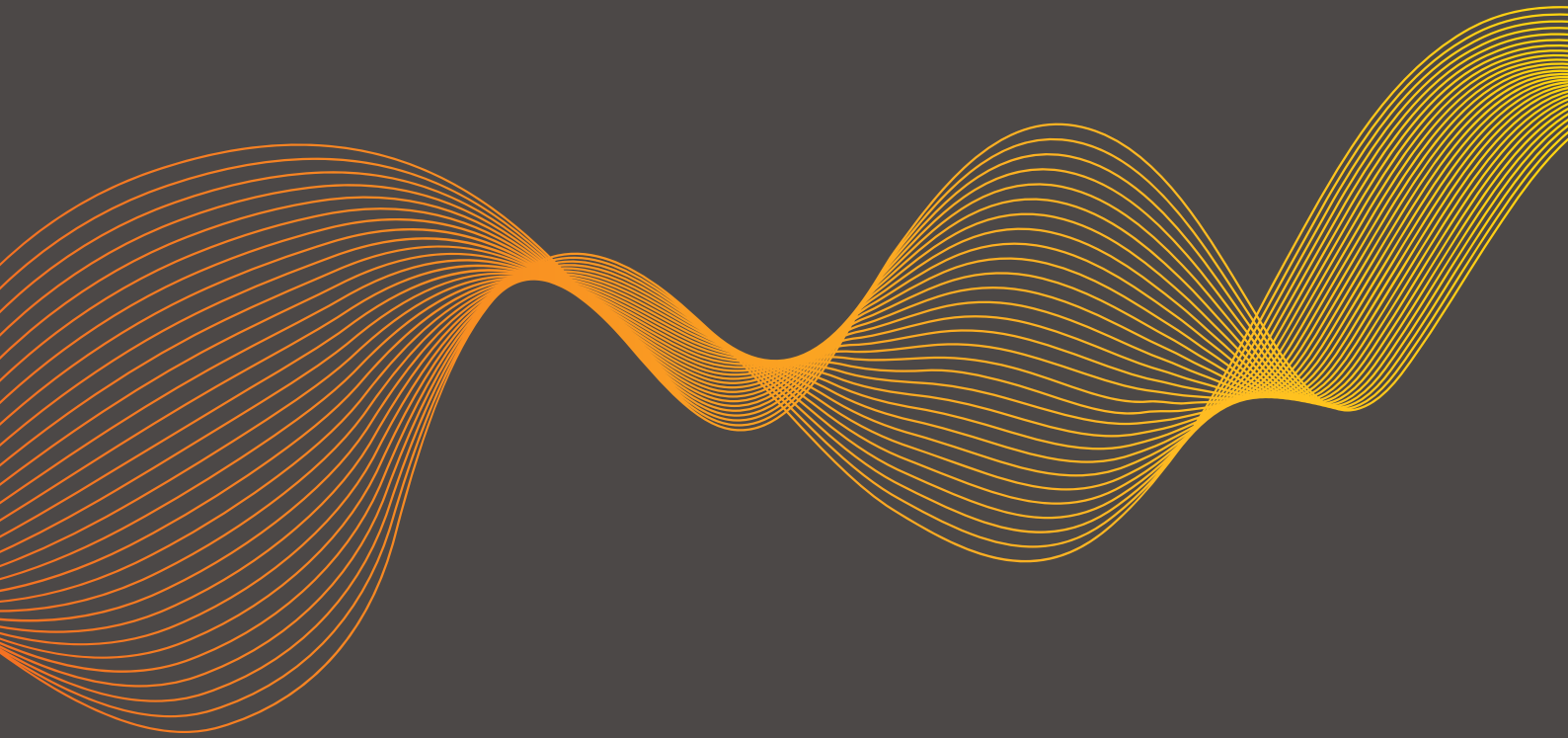



A successful organisational design will uphold the principles of familiarity, flexibility and visibility.

6.1. Introduction

Following on from the OST viability report conclusion that familiarity is a key requirement in the design of any organisation structure or process to deliver Distributed ReStart, existing business processes and systems are maintained in our proposals wherever appropriate, thus reducing the need for new systems and skills. In the interests of simplicity and clarity, the number of interface points within new processes is also minimised.

The project recognises that there are many changes currently taking place across the energy industry. A particularly important initiative for Distributed ReStart is the development of the Distribution System Operator model and the requirements for active management of DERs. This is one of the drivers for the development of multiple organisational models by OST. These provide a set of different control methodologies which can be adapted to meet various lead party options and automation appetites across the electricity industry. These methodologies have been widely consulted on, through industry forums, such as the ENA Open Networks project, and bilaterally with potential Distributed ReStart participants.

Figure 6.1

Network control boundaries by DNO licence area

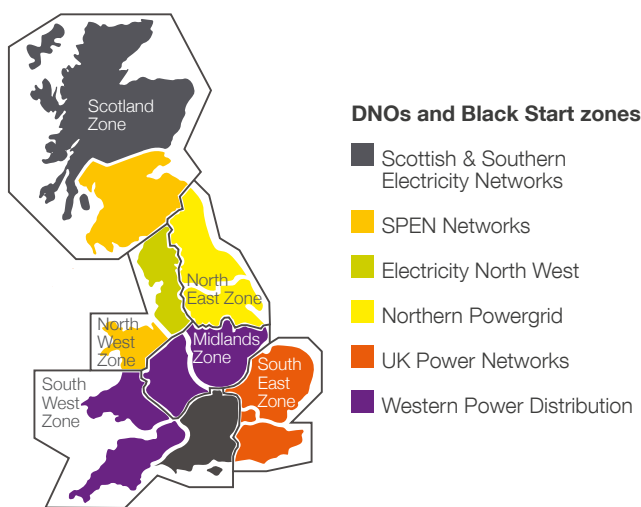

6.2. Organisations in Black Start

Under Black Start, NGEN is currently the lead organisation for every process stage from declaration through to the end of Black Start. Within this process NGEN is responsible for instructing the start of the transmission level restoration called the local joint restoration plan (LJRP). The LJRPs contain information pertaining to actions required by the Black Start service provider(s), the DNO demand and the TO network options for energisation. In this report, these entities involved are collectively referred to as Black Start participants.

Responsibilities for specific actions are appropriately distributed amongst the Black Start participants with NGEN providing a coordinated national approach. Under specific circumstances outlined in Operating Code 9 (OC9) [2], the Scottish TO may be delegated the authority of the Electricity System Operator within their specific transmission licence area, but at any stage control can be taken back by NGEN.

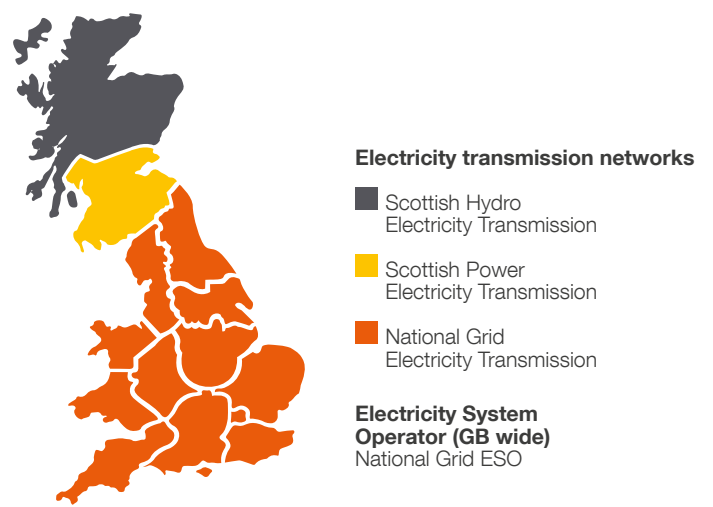

These same entities continue to be involved in Distributed ReStart. However, the Black Start service provider is a DER and the restoration plan is focused on distribution network energisation strategies which, in turn, provide a collective restoration capability at the transmission network point of connection (POC).

Organisational impact analysis during the viability stage identified that the key affected functions are:

- NGESO;
- Scottish transmission network owners (TOs);
- DNOs; and
- DERs involved within a DRZ.

The TOs only experience a change in requirements in Scotland where the TOs share joint capability and operational requirements with the respective DNOs. For this reason, whilst considered at every stage, no detailed organisational proposal is provided for the TO function as no significant change is anticipated.

Table 6.1

Table showing current operational responsibilities in Black Start

Action	Existing Black Start responsibilities
Declare Black Start	NGESO
Responsible for national strategy	NGESO
Responsible for regional strategy	NGESO/STO
Instruct start of plan	NGESO/STO
Instruct transmission switching actions	NGESO/STO
Physical transmission network actions	TO
Instruct distribution switching actions	DNO
Physical distribution network actions	DNO
Instruct DERs	N/A
Physical actions of contracted generation	Provider
Instruct non-contracted energy resources	NGESO
Frequency leader	NGESO/STO

6.3 Key Black Start operational responsibilities

Taking the requirement for familiarity, changes to roles and responsibilities have been minimised where appropriate in the design of any organisation structure or process to deliver Distributed ReStart. Table 6.1 displays the current operational responsibilities of each entity in Black Start, noting that due to the lack of DER involvement in the current model, DER are not directly considered or involved.

6.4 Approach

Clarity of roles and responsibilities and effective co-ordination of available resources are the corner stones of any Black Start process. Outputs from the OST viability analysis, stakeholder consultation, and international best practice [3] have been used to develop process and organisational structure proposals.

At the project viability stage, four different control models for Distributed ReStart were developed with either NGESO or the DNOs as the principal control party within a restoration zone, using either entirely manual or entirely automatic processes. The four models (A-D) are illustrated in figure 6.2.

Figure 6.2

Viability stage control models

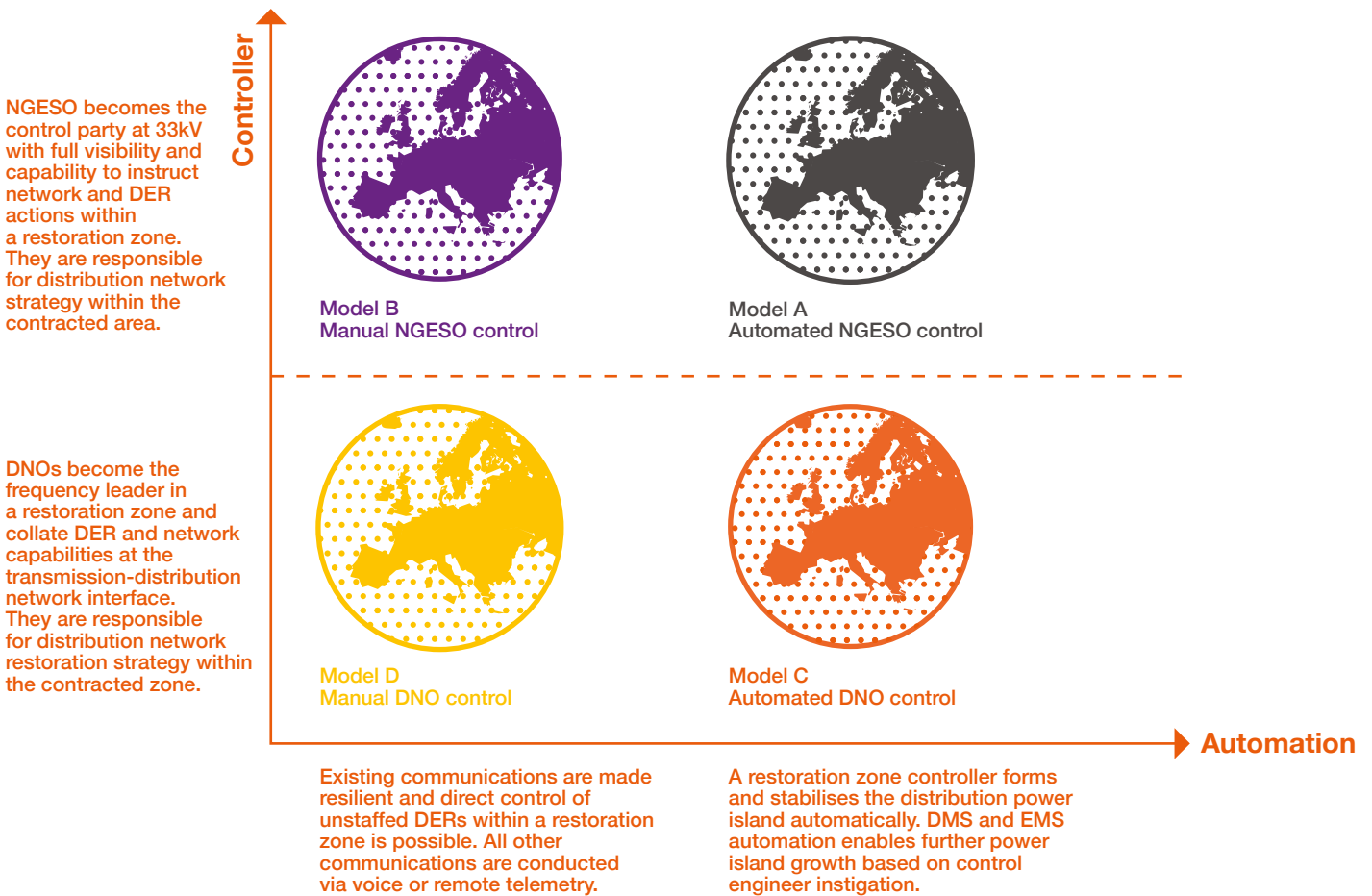

All models have relative merits, difficulties and risks including, in some models, key shifts in capabilities and responsibilities for the principal control party.

A key consideration in the process design stage has been the Distribution System Operator worlds being explored through the ENA Open Networks project. Whilst the models adopted by Distributed ReStart have not been dictated by the 'Worlds' developed by Open Networks, Open Network project reports have been evaluated and a series of collaborative sessions held between the two projects. Both DNO led and NGENSO led models have been refined to align with 'ENA World B – Coordinated DSO-NGESO procurement and dispatch' which Open Networks found to be the control option for DSO with the least-worst regrets.

In addition, feedback from DNO and NGENSO control engineers, DER operators, our stakeholder advisory panel, strategic telecommunications group and CIGRE restoration working group contributions have all formed part of the design stage consultation process.

The project has developed process maps against the options for delivery of model B and model D adopting a continuous improvement and feedback cycle to improve the methodology. The manual process options were used

because they provide a base point to assess the overall benefit of automating individual process steps and provide a redundant capability should any automation be introduced. Furthermore, it enabled assessment of the most appropriate entity to be executing roles and the relative efficiencies of each process model. This overall iterative method has resulted in a single collaborative organisational model which is proposed in section 8 and found to leverage the benefits of both models in isolation.

In parallel, initial control schemes have been developed to create a Distributed ReStart Zone controller (DRZC) as depicted in figure 5.1. The objective of a DRZC is to establish and stabilise the distribution level power island and to use the collective capability at the point of connection to provide an outward energisation or synchronisation capability. These control schemes align with the procedural steps which have been identified as most impactful for automation in the process map in section 8.3.

Once available, a detailed analysis of DRZC design options will be included in a separate Power Engineering requirements publication. However, key concepts are discussed in section 9 of this report and the impact these have on organisational structure is given in section 10.

6.5 Restoration strategy

Multiple restoration strategies exist worldwide, as dictated by the needs of local systems and generation mixes. These strategies include sequential or parallel restoration options.

- In parallel approaches, multiple self-starting resources are started and synchronised together at an intermediary network point.
- In sequential approaches, a single generation source energises the system to the point of additional generation for connection. [4] [5] [6].

In the current GB Black Start process, individual LJRPs are sequential, but the national strategy is a parallel process with multiple power islands intended to be started nationally. The project has reviewed the relative merits of these approaches and defined a process based around sequential restoration within a DRZ. There are two key reasons for this:

- the cost of making multiple local resources self-starting would increase the cost of DER led restoration; and
- most 33kV/11kV network areas only have 1 suitable Anchor DER [7].

Distributed ReStart process maps are therefore sequential, but the organisational requirements to deliver Distributed ReStart are based on the execution of multiple processes in parallel. Conventional Black Start capability assumes six plans can be executed in parallel. It is anticipated that multiple DRZ plans are likely to be needed to replace a single conventional Black Start provider due to the smaller scale of the energy resources but further analysis through the refine stage will show the practical limitations for this parallel operation.

The specific switching actions required are bespoke for each DRZ as they are dependent on the characteristics of the available DERs and the networks involved. The switching actions will always be a compromise between:

- (a) the requirement to restore the network as quickly as possible, including minimisation of switching actions
- (b) the need to restore the system in a way that doesn't result in any network damage or breach to frequency or voltage limits.

Across this process, due consideration for the impact of cold load pick-up and the block load pick-up capability of Anchor DERs (ADER) must be given.



Throughout the design stage we have looked to review and refine the organisational models to develop solutions to identified challenges.

7.1. Introduction

The findings from the viability stage demonstrated that no single model in its proposed format could be executed without some degree of organisational change. The summary table 7.1 presents an overview from the viability stage analysis [8].

Another key issue the analysis highlighted is that some degree of automation is required to mitigate against the training and additional staff requirements of manual processes. However, fully automated processes have barriers due to the significant change from current operational methods and the operational risk associated with an emergency restoration plan which relies on pre-programmed procedures.

The high level analysis guided the design stage approach of developing detailed manual processes and consulting

with industry to assess for which process steps control engineer intervention is desirable and which steps require onerous levels of labour time or introduce new skillsets.

The process development has been executed in parallel to a DRZC specification conducted by the Power Engineering and Trials workstream which provides detailed methodologies for automating components of the restoration process.

These two elements have been used to develop the automation requirements, ensuring a balance is met between these options to avoid the identified drawbacks of either extreme approach.

Furthermore, analysis of DNO and NGENSO led procedures has enabled a more balanced approach to role distribution to be considered as compared with the viability stage and draws out the requirements to facilitate these capabilities. This has been used to develop the initial process design proposed in section 8.

Table 7.1
Viability stage finding summary table

Category	Organisation	Outcomes of organisational analysis				
		Present capability	Model A	Model B	Model C	Model D
Control staff	NGESO	23 control engineers	Yellow	Red	Green	Green
	TOs	2 to 5 control engineers under minimum staffing	Green	Green	Green	Green
	DNOs	2 control engineers minimum	Yellow	Yellow	Yellow	Red
	Providers/DERs	2 control engineers minimum	Yellow	Yellow	Yellow	Yellow
Support staff	NGESO	Dedicated support teams	Green	Green	Green	Green
	TOs	Reliant on policy for additional resourcing	Green	Green	Green	Green
	DNOs	Reliant on policy for additional resourcing	Green	Yellow	Yellow	Yellow
	Providers/DERs	Do not rely on additional resource	Green	Green	Green	Green
Skill requirements	NGESO	Energy, strategy, transmission control	Yellow	Yellow	Yellow	Green
	TOs	Transmission control	Green	Green	Green	Green
	DNOs	Distribution control	Yellow	Yellow	Yellow	Yellow
	Providers/DERs	Start-up/Shutdown	Green	Yellow	Green	Yellow
Training processes	NGESO	Yearly training	Green	Yellow	Yellow	Green
	TOs	Biennial training	Green	Green	Green	Green
	DNOs	Yearly knowledge share	Yellow	Yellow	Yellow	Red
	Providers/DERs	During authorisation and assurance	Green	Yellow	Green	Yellow
Supplementary criteria	Meets Black Start needs	Present needs met	Yellow	Red	Green	Yellow
	Ease of Implementation	Functional process exists	Red	Yellow	Red	Yellow
	Flexibility for the future	Threatened by closure of large conventional providers	Yellow	Green	Yellow	Green
	Alignment with wider industry change	Does not fit the themes of decentralisation, decarbonisation or digitisation	Red	Yellow	Yellow	Yellow

7.2 Process design objective

From the viability stage analysis, we established the design principles of flexibility, familiarity and visibility. The Distributed ReStart models have been evaluated against these criteria.

7.2.1 Flexibility

All restoration procedures should be adaptable and contain more than one network energisation route. This applies for both manual and automated solutions.

Where automation is recommended, manual procedures should still be retained to create redundancy in the process and maintain the option for strategy to be changed during the Black Start event given the highly uncertain operational scenario.

7.2.2 Familiarity

As far as possible, the procedures should emulate normal operational scenarios. Where this is not possible, training requirements will be developed in the refine stage based on desktop exercise outcomes.

7.2.3 Visibility

A minimum requirement across all procedures is the ability of the relevant control party to have situational awareness. This means access to metered data, asset state information and overall procedural progress to the extent that is required

for the specific role being executed. This will link to proposed information exchange steps in procedures as well as introducing real-time data transfer requirements which affect DRZC and system design. It is noted that this requirement is subjective so desktop exercises will apply scrutiny to this through direct participant feedback in the refine stage of the project.

7.3 Organisational model A

Under model A, NGENSO is the lead coordinator of a Distributed ReStart Zone and utilises a DRZ as part of national transmission restoration strategy. This requires NGENSO to be the control party at 33kV with situational awareness at this voltage level. It also requires close cooperation with the DNO who remains responsible for demand and network management outside of the DRZ.

Instructions are issued to the control system by NGENSO, this coordinates the output of DER to provide the requested real and reactive outputs at the point of transmission network connection (POC), whilst using fast balancing actions to provide power island stability and voltage and frequency management.

Figure 7.1

Diagram showing the communications which occur between parties to facilitate an automated NGENSO controlled Black Start in parallel with existing LJRPs

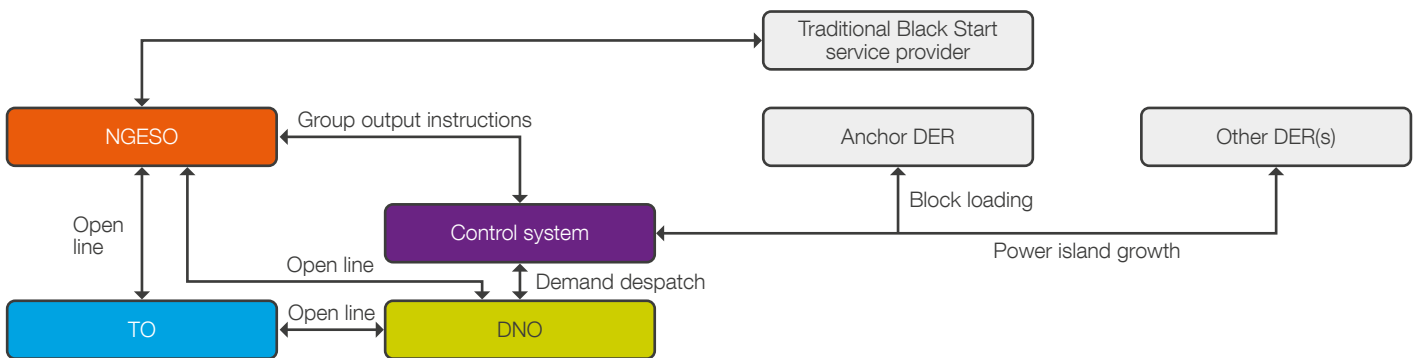

7.4 Organisational model B

In model B, NGENSO is the lead coordinator of a Distributed ReStart Zone and utilises a DRZ as part of national transmission restoration strategy. This requires NGENSO to be the control party at 33kV with situational awareness and an ICCP link to have access to all network monitoring and status information. Switching actions are conducted by the DNO following a process equivalent to the System Operator – Transmission Owner Code Procedure (STCP) interfaces defined at transmission level.

NGESO instructs DERs' output directly, except under block loading where the very fast coordination actions required between the DER output and the demand needs open line communication between these parties equivalent to the block loading stage of conventional Black Start. Droop control settings on DERs and flexible demand control are used for fast control required to deliver power island stability, but manual control is retained over individual DER and network asset setpoints.

Figure 7.2

Diagram showing the communications which occur between parties to facilitate a manual NGENSO controlled Black Start in parallel with existing LJRPs

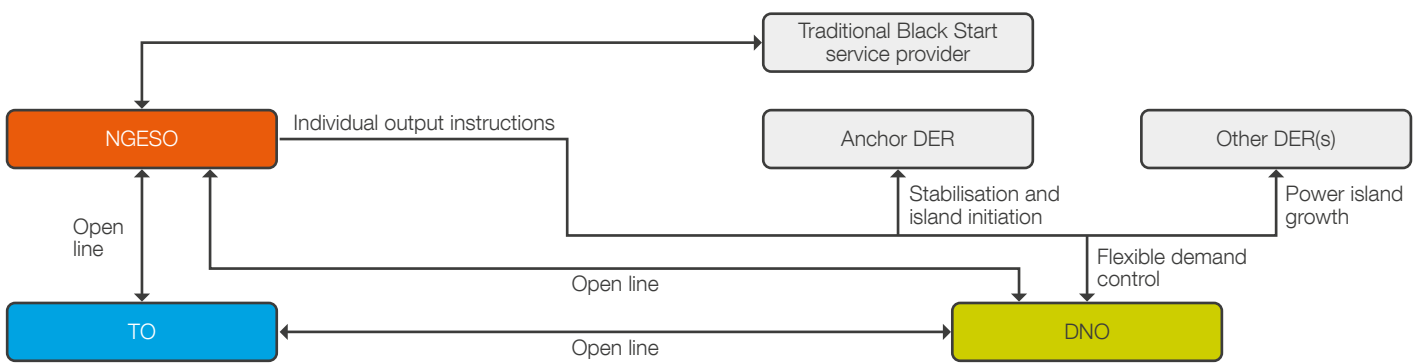

7.5 Organisational model C

In model C, the respective licence area DNO is the lead coordinator of a DRZ. After a DRZ is established and local demand is fed, additional resources are released to NGENSO

for use in transmission network restoration. Instructions are issued to the control system by the DNO, this coordinates the output of DER to provide the requested real and reactive outputs at the POC, whilst using fast balancing actions to provide power island stability and voltage and frequency management.

Figure 7.3

Diagram showing the communications which occur between parties to facilitate an automated DNO controlled Black Start in parallel with existing LJRPs

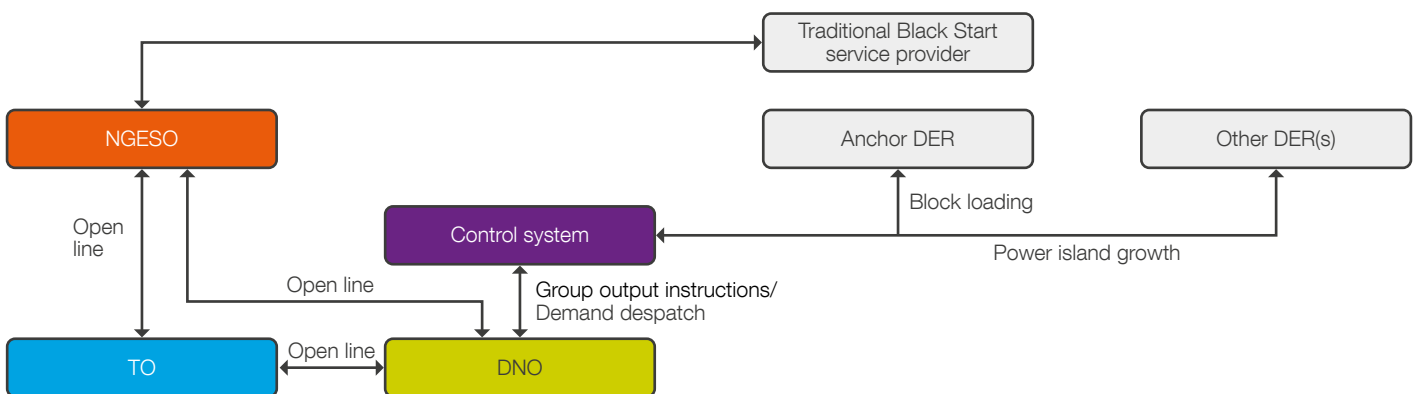

7.6 Organisational model D

In model D, the respective licence area DNO is the lead coordinator of a DRZ. After a DRZ is established and local demand is fed, additional resources are released to NGESO

for use in transmission network restoration. Instructions are issued directly to DER via the DMS system through manual control engineer intervention. Droop control settings on DERs and flexible demand control are used for fast control required to deliver power island stability, but manual control is retained over individual DER and network asset setpoints.

Figure 7.4

Diagram showing the communications which occur between parties to facilitate a manual DNO controlled Black Start in parallel with existing LJRPs

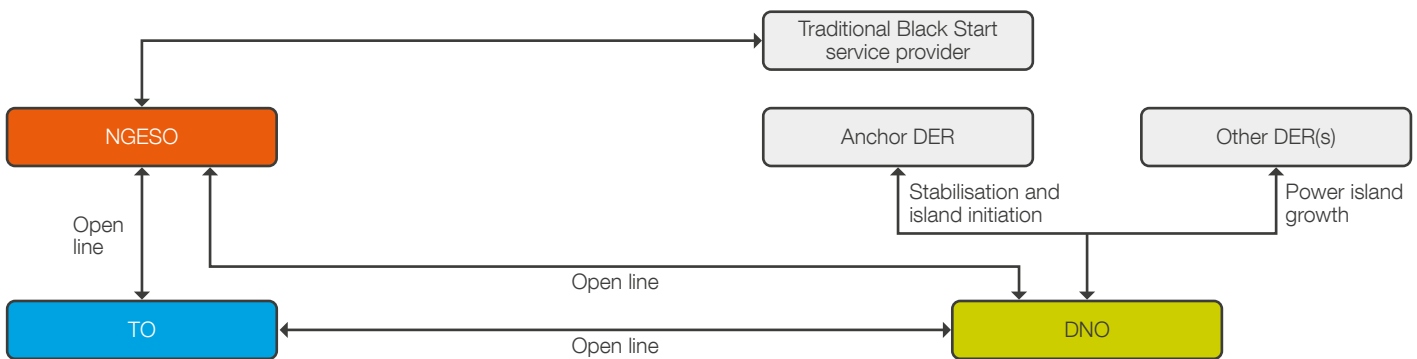

7.7 Key design inputs

7.7.1 Stakeholder input

As discussed in section 3, stakeholder input has been integral to the development of organisational and process designs.

An important initiative for OST is the ENA Open Networks project. A key element of Open Networks is supporting the transition towards Distribution System Operator capability, enabling DNOs to take a more active role in managing their networks to support whole system challenges through utilising DERs. Due to the direct alignment of goals between the Distributed ReStart project and the wider aims of this programme, we have extensively engaged with workstream 1B and, where appropriate, sought to align Distributed ReStart organisational and systems proposals with their findings.

Since OST developed the Distributed ReStart organisational models, the Open Networks project has found that the Open Networks World B – DSO-NGESO coordinated procurement and dispatch is the least-worst regrets option [9]. Within this, there are a range of transition paths which are considered possible, including a shift towards World D – Electricity System Operator coordinates or World E – Distribution System Operator coordinates, dependent upon wider market developments.

Our initial proposals for NGESO led and DNO led processes broadly align with World D and World E respectively and encompass these range of future options. Across the design stage, the process steps required for these models have been fully mapped and consultation has been used to appropriately split the responsibilities to meet a coordinated DSO-NGESO dispatch methodology in line with ENA findings.

In the Distribution System Operator roadmap, System Defence and Restoration is considered as a core function for Distribution System Operators. This report recognises that distribution networks and resources can play an increasing role in overall electricity system resilience and re-establishment in the event of a major system incident. Proposals from the Distributed ReStart project are identified as feeding directly into this ongoing work [10].

Figure 7.5

Figure showing the relative alignment of Distributed ReStart models, ENA Worlds, transition paths and future organisational change scenarios. Please note, timelines are indicative only and shifts in automation and coordination may occur rapidly dependent on technology and regulatory developments.

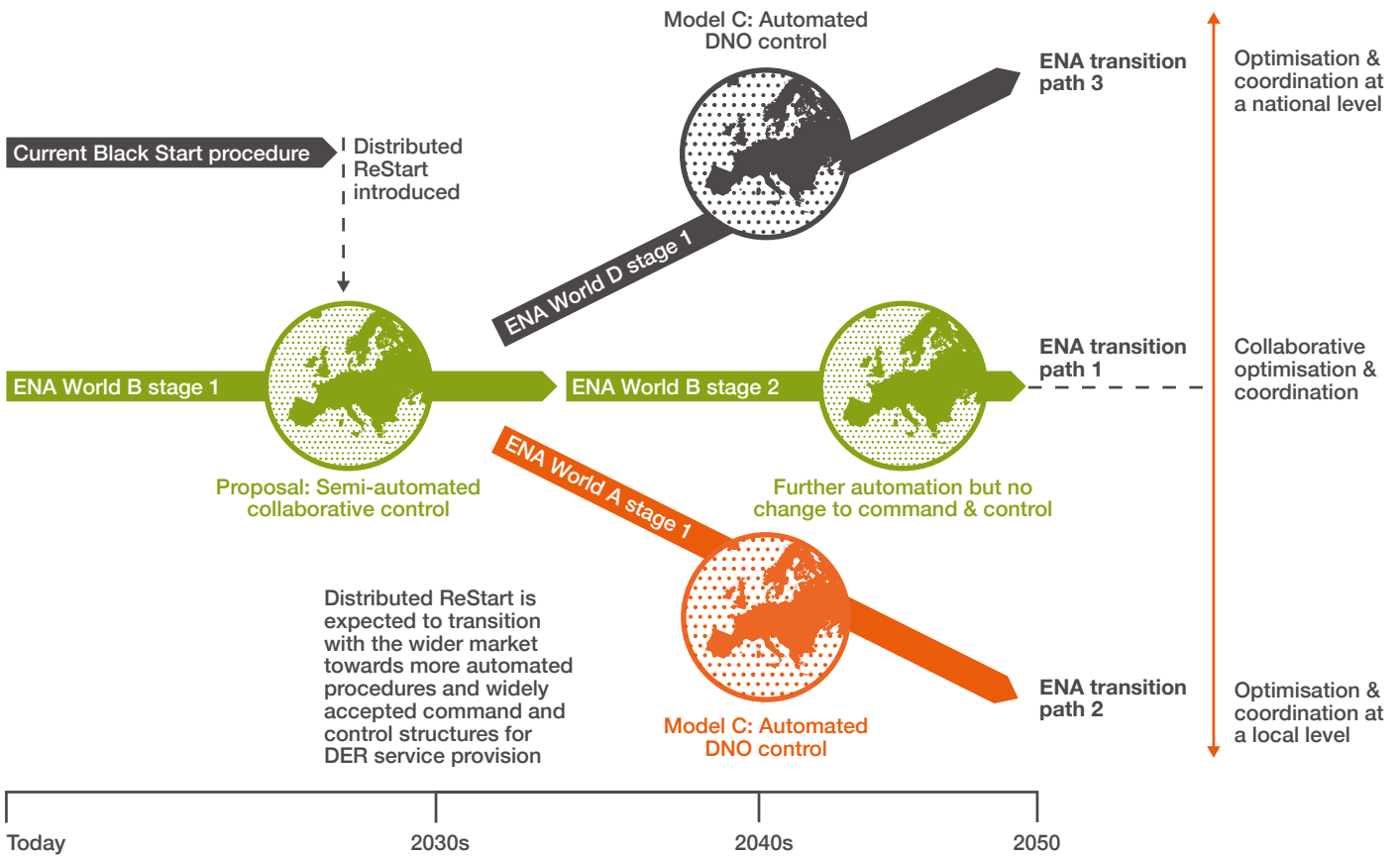

7.7.2 Technical inputs to process design

There is a clear interdependency between power engineering requirements and the overall service coordination. The DRZ introduced in section 5 is a key concept used across Distributed ReStart and the following key power engineering findings are incorporated into the process design [1]:

- (1) An Anchor DER is required in all plans. This Anchor DER will be capable of providing a voltage and frequency reference for the power island.
- (2) The block load pick-up capability of an Anchor DER may be less than the practical segregated demand that will be energised from a single action. Therefore, the process must allow for an additional resource to enhance the block load pick-up capability. If used, this resource will also provide the minimum stable demand for the Anchor DER. For the purpose of this report, this is considered to be a source of dispatchable demand.
- (3) Additional energy resources will be required to enhance the power island's real and reactive power range. Connection of generation should be prioritised over the connection of demand to result in the fastest overall restoration and to provide further support services. However, this will depend upon the specific switching plan so flexibility should be retained.

- (4) Energisation to the point of synchronisation (inclusive of transformer energisation where applicable) may take place ahead of connection of customers to reduce the impact of voltage dips or over-voltages. The process should provide flexibility to account for this.
- (5) Soft energisation of the transformers may be incorporated into the pre-energisation stage switching programme for cases where inrush current is identified as an issue. The process should provide flexibility to account for this.
- (6) Where a plan energises 400kV, a fault infeed source will be needed at either 132kV or 275kV to enable protection operation.

7.8 Process assumptions

In order to develop processes for the control and coordination of DRZs, a series of inputs have been assumed. These assumptions will be tested during the project refine stage as further project conclusions are made.

Key assumptions for the process development include:

- (1)** A commercial or codified control interface exists with all energy resources within the DRZ boundary or on the route of the outward energisation plan.
 - This provides for all DERs to follow DNO or NGENSO instructions as though they were an emergency instruction. The specific mechanism by which this is achieved is out of scope for this report and is discussed under the complementary procurement and compliance report.
- (2)** A DRZ consists of more than one DER providing a collective transmission energisation service and/or demand restoration product.
 - A methodology for coordinating the actions of these resources to deliver a single service is considered.
- (3)** Both staffed and unstaffed sites will accept control signals and be able to respond automatically under all models.
- (4)** Anchor DERs will not be required to automate their start-up procedure under manual or automated proposals.
- (5)** Any party taking coordination actions must have situational awareness of the networks and DERs included within a DRZ.
 - This has limited allocation of coordination actions to NGENSO, the licence area STO, or the licence area DNO.
- (6)** ICCP between NGENSO and the DNOs are in place within project timescales as part of wider Distribution System Operator works.
 - These can provide NGENSO with situational awareness of the distribution networks.
- (7)** The process starts from a total blackout scenario.
 - It is appreciated that restoration of demand for other purposes such as a partial blackout, or localised islanding is valuable.
 - The principles for each scenario remain common, but a total blackout represents the most onerous operational scenario.
- (8)** Not all plans will include a transmission energisation procedure.
 - A break point is given in all procedures to allow for a distribution level only restoration service.
- (9)** All DRZ have an associated transmission restoration plan.
 - DRZ that follow assumption (8) will involve synchronisation to an existing power island only.

7.9 Stages of restoration

All organisational models have been mapped against the required actions to deliver Black Start against these design inputs and process assumptions. The lead control party was used as the start point for action allocation and subsequent analysis of the time and workforce efficiency has been used to develop the overall command and control method proposed in section 8.

Key stages of restoration are discussed, mapping the progress of the restoration against the Chapelcross case study illustrated in figure 7.6.

7.9.1 Declaration and initiation

It may not always be obvious when a Black Start condition exists. GC Operating Code 9 gives the NGENSO Power System Manager the capability to declare Black Start as part of the recovery process following a total or partial shutdown. In the event of a partial shutdown, this declaration includes whether the disturbance meets the market suspension threshold or if the total system is able to be restored to normal operations without market suspension.

A key issue which has potential to delay restoration is the reliance on self-starting or called in resources. Public communications systems are not power resilient and therefore standard emergency site attendance procedures may not be suitable. Starting the Anchor DER has potential to be the longest individual action across the critical path of the restoration and this should feed into the technical assessment criteria and include any delay caused due to non-permanent staffing.

Figure 7.6

Simplified Chapelcross case study diagram for indicative purposes to demonstrate network actions that have been taken at each stage. Where possible, viable switching plans identified in the PET design stage paper are included [1].

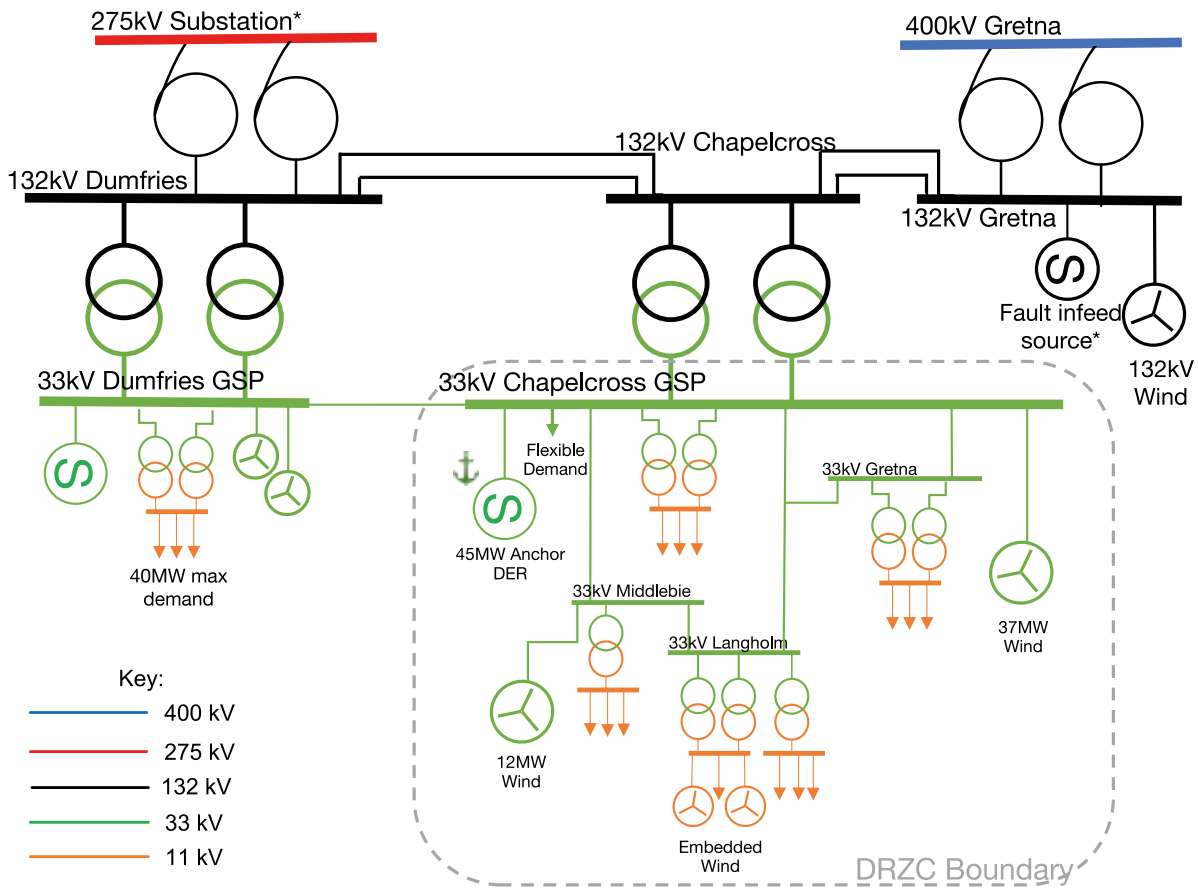

* For illustrative purposes only the chapelcross network area has been altered

Table 7.2

Declaration and initiation key actions and responsibilities

Action	NGESO led owner	DNO led owner	Parties involved	Included in DRZC scope
Identify a Black Start condition exists	NGESO	NGESO	All	No
Declare Black Start to DNO and TO	NGESO	NGESO	All	No
Declare Black Start to DRZ participants	NGESO	DNO	All	Yes
Begin internal reorganisation, call in required personnel, establish command and control structures	All	All	All	No

7.9.2 Information gathering

There are many potential causes of a Black Start, however it is anticipated that most protection systems will have operated and that networks and generation will be in an unknown state. This means the control engineers across all DRZ participants will be required to clear alarms, assess any damage and begin switching assets in line with a pre-defined Black Start preparation plan to ensure appropriate readiness

to enact a DRZ if requested. This process will be iterative as further information is gathered from preparation actions. An Anchor DER must confirm their availability to Black Start through data exchange, whilst direct ICCP link and voice communications will be used to report availability information between the TOs, DNOs and NGESO to establish overall DRZ availability and potential for use in supporting transmission restoration.

Table 7.3

Information gathering key actions and responsibilities

Action	NGESO led owner	DNO led owner	Parties involved	Included in DRZC scope
Information gathering	All	All	All	No
Clear alarms and follow network preparation asset switching plans	All	All	All	No DMS automation
Establish availability of DRZ	NGESO	DNO	All	Yes
Develop national restoration strategy	NGESO	NGESO	NGESO	No
Develop regional restoration strategy	NGESO	DNO	NGESO, DNO	No
Where DRZ cannot self-sustain without transmission network access for more than 24 hours, hold for network readiness	NGESO	NGESO	NGESO, DNO	No

7.9.3 DRZ instruction

Overall availability of restoration options (DRZs and LJRPs) will be established through the information gathering stage. Additional availability information from non-Black Start transmission connected resources and large distribution connected providers will be considered as part of a holistic national restoration strategy. Where a DRZ is valuable within this process, a regional restoration strategy defining

potential synchronisation points and evaluating priority and timings for the instruction of plans to optimise overall restoration is required. The capability of a power island to self-sustain output without external connection is a key issue for understanding if NGESO intervention is required in the instruction of DNO led processes. Where a plan can self-sustain for an extended duration there should be no requirement for NGESO to intervene.

Table 7.4

DRZ instruction key actions and responsibilities

Action	NGESO led owner	DNO led owner	Parties involved	Included in DRZC scope
Confirm plan readiness with DNO, TO and Anchor DER	NGESO	DNO	All	No
Instruct start of the DRZ to all DERs	NGESO	DNO	All	No

7.9.4 Pre-energisation

The specific switching actions required are bespoke for each DRZ as it is dependent upon modelling the characteristics of the available DERs and the networks involved.

For this reason, the pre-energisation stage involves switching the network into an optimised state that minimises the number of on-load switching actions that are required and, where applicable, enables a soft voltage ramp procedure to prevent the introduction of excessive inrush currents. Furthermore, DRZ protection settings will need to be remotely changed, low frequency demand disconnection relays will need to be disabled and an earth reference will need to be switched in.

Whilst the network is being configured, the Anchor DER should continue its start-up procedure until the hold point, this is defined as the status where it can energise the network within 30 minutes from instruction to keep consistency with the existing Black Start procedure.

At this stage, a specific restoration route from the pre-defined options will be selected and instructed, determining the order of network, DER and demand connection. The Power Engineering and Trials – Power Systems Studies Part 1 report includes a detailed discussion of the options included within these switching procedures.

Table 7.5

Pre-energisation key actions and responsibilities

Action	NGESO led owner	DNO led owner	Parties involved	Included in DRZC scope
Follow pre-energisation asset switching process	DNO, TO	DNO, TO, Anchor DER	All	No
Follow internal Black Start procedure to the hold point	Anchor DER	Anchor DER	Anchor DER	No, See assumption (4)
Develop local restoration strategy	NGESO	DNO	All	Yes
Instruct restoration option	NGESO	N/A	NGESO, DNO	Yes

7.9.5 Anchor DER stabilisation

The project has identified that the block load capability of a DER is not typically large enough to meet demand which can be efficiently segregated [1]. This leads to the requirement for an enhanced block load pick-up service. Options for procuring this service are discussed in the complementary Procurement and Compliance design stage report but the organisational structure accepts that this could be provided locally at the generator site, or via a remote third-party enhanced block load service provider. A technology neutral functional specification document will be published detailing the requirements against this but for the purpose of this report, it is treated as a flexible and controllable demand source.

For the duration of the stabilisation process, extremely close coordination of DER output and demand are required to ensure the Anchor DER remains within its allowable operational range. This is a key capability of the controller specification but, where manual, must be executed by the DNO in an equivalent manner to conventional block loading.

Where appropriate, the DNO will energise to the point of flexible demand connection and instruct the appropriate load increments to be applied, coordinating between the Anchor DER and the flexible demand to achieve stability.

Figure 7.7

Indicative network energisation after the Anchor DER stabilisation stage (highlighted sections are to be considered energised)

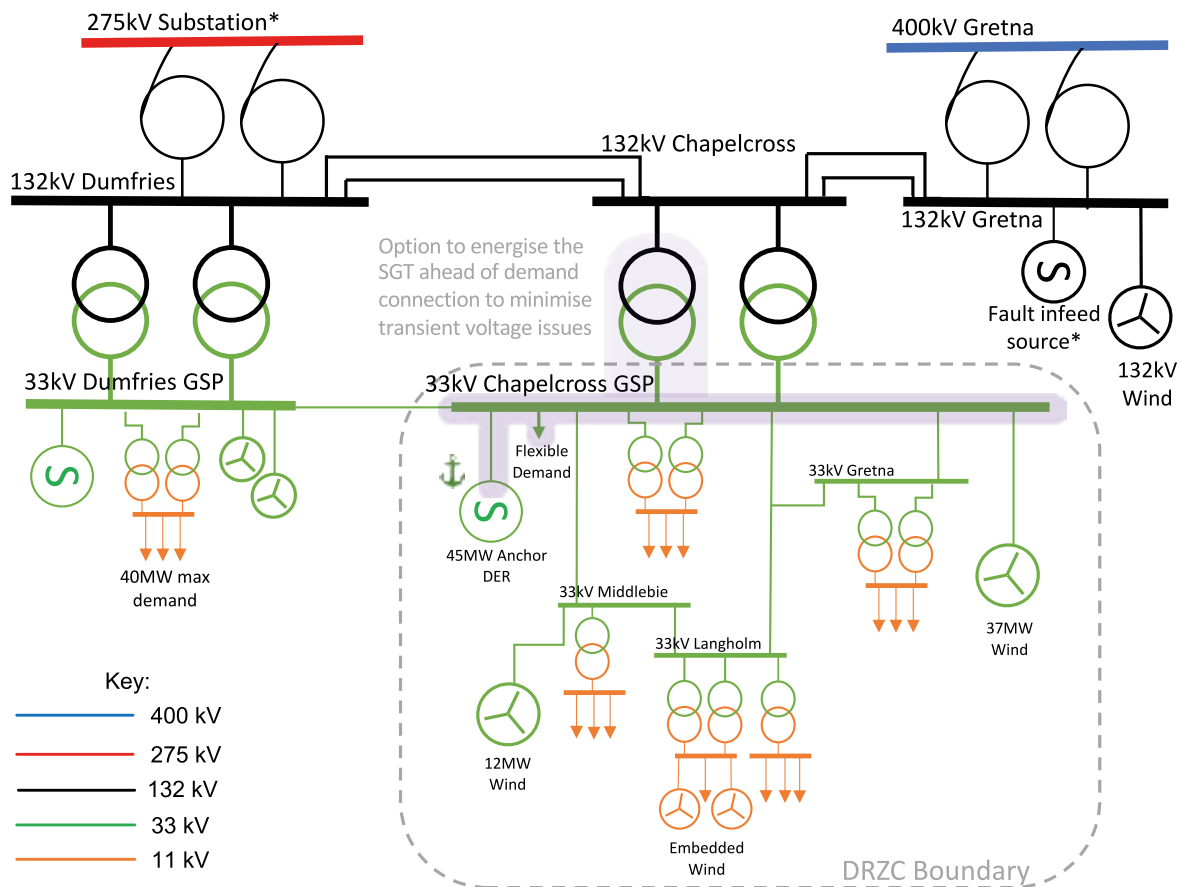

Table 7.6

Anchor DER stabilisation key actions and responsibilities

Action	NGESO led owner	DNO led owner	Parties involved	Included in DRZC scope
Hold for generator energisation readiness	DNO	DNO	DNO, Anchor DER	No
Instruct network energisation	DNO	DNO	DNO, Anchor DER	Yes
Energise to the point of flexible demand connection	DNO	DNO	DNO	Yes
Coordinate the ramp-up of the Anchor DER against the flexible demand	DNO	DNOI	DNO	Yes
Acknowledge stabilisation	NGESO	NGESO	NGESO, DNO	No

7.9.6 DRZ power island growth

Once a minimum stable output is achieved, the DNO will follow the switching procedure to the point of connection for DERs providing additional support services. It is anticipated that the power output will be curtailed to an output figure that can reliably be achieved by stochastic generation sources or is within the headroom capability of the dispatchable DERs.

Depending on the plan, there may be a requirement to energise the 33kV/132kV transformer and some 132kV network ahead of demand connection to prevent unacceptable transient voltages at customer sites. This will depend on the specific case, but in Scotland may result in transmission network energisation. Ahead of transmission network energisation, NGESO should be consulted to ensure appropriate transmission network separation has been completed.

Figure 7.8

Indicative DRZ power island growth stage 1 with energisation to the point of connection for all controlled DERs within the zone (highlighted sections are to be considered energised)

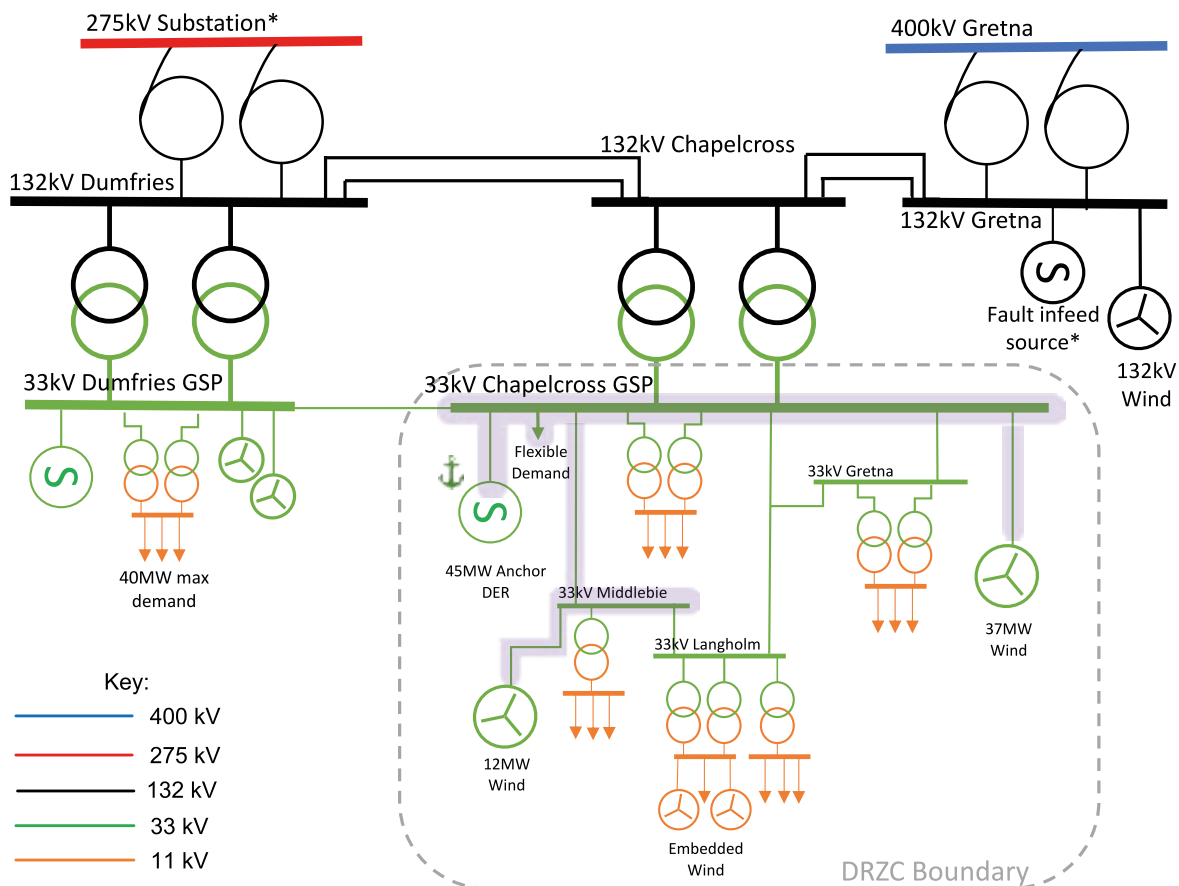

After the anchor generator is stabilised and the pre-block loading switching plan is delivered, the demand expected from an 11kV primary substation will be forecast. A demand changeover process will then be implemented between the flexible demand and the network demand, reducing the step change to the demand forecast error. For this process to be coordinated manually, a capability to issue time synchronised instructions to the flexible demand and the

primary substation circuit breakers would be needed or a local droop control method would be needed on the flexible demand. Control schemes which achieve this process are discussed in the Distributed ReStart Zone controller section of this report. This is an iterative process and will require an open line between the DNO and the Anchor DER to take demand shedding actions if required to protect the overall power island stability.

Figure 7.9

Indicative DRZ power island growth stage 2 displaying the sequence of load connection in the Power Engineering and Trials – Power Systems Studies Part 1 report [1] (highlighted sections are to be considered energised)

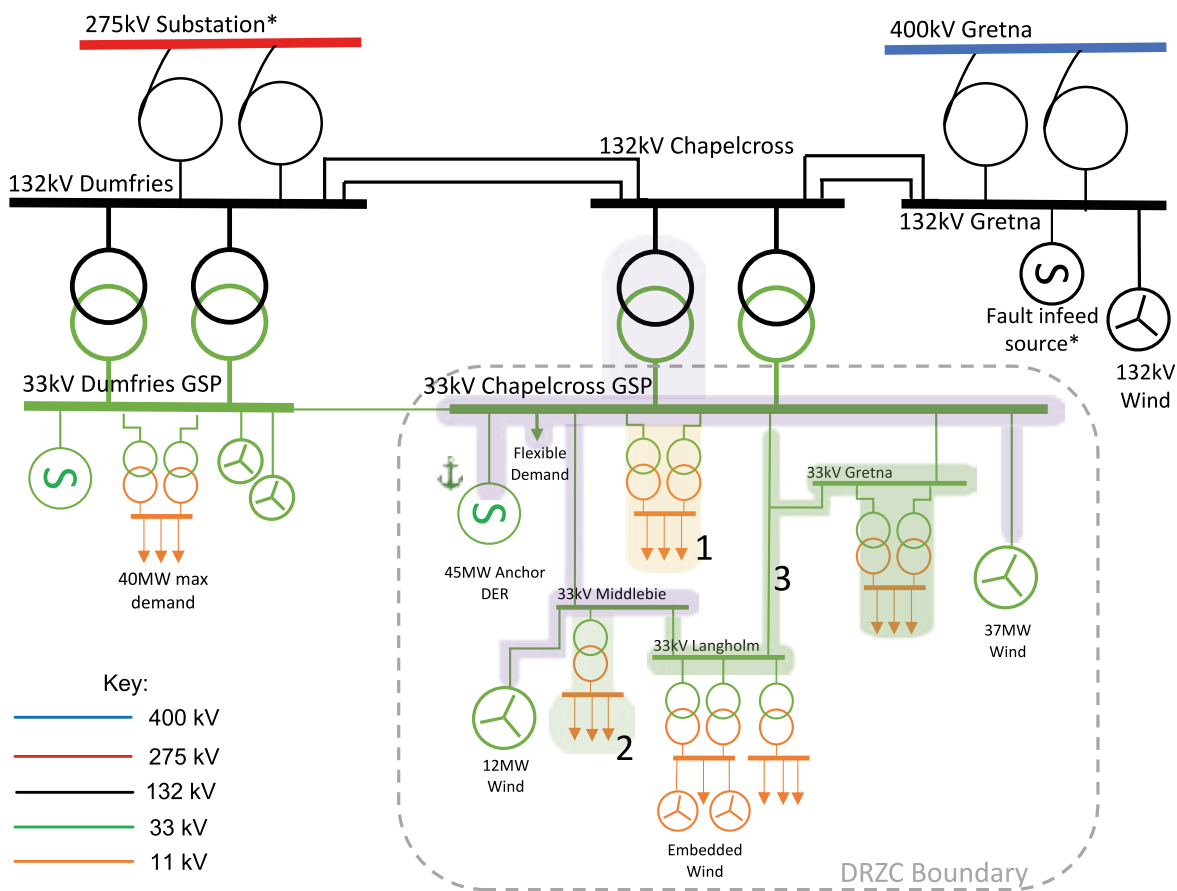

Depending on the switching programme, a final stage of energising redundant circuits may be completed, minimising the risk of a fault causing network instability but potentially increasing the power island reactive power requirement. It is worth noting that not all DERs may provide a service within the DRZC boundary and not all demand may be possible to meet with the connected island power resources.

At this stage of Black Start, the technically optimal loads will be energised and no customers will be considered to have a higher priority. In addition, embedded 11kV generation which no DRZ participant can control will be avoided and feeders which have very high penetration of lower voltage embedded generation may not be energised until later stages to protect overall power island stability.

Table 7.7

DRZ power island growth key actions and responsibilities

Action	NGESO led owner	DNO led owner	Parties involved	Included in DRZC scope
Instruct energisation to the point of additional service providers	NGESO	N/A	NGESO, DNO	Yes
Energise to the point of additional service providers	DNO	DNO	DNO, Anchor DER	Yes
Instruct service provider to synchronise to the power island	NGESO	DNO	NGESO, DNO, DERs	Yes
Ramp power and reactive power to agreed setpoint	DER	DER	DER	Yes
[Possible requirement to skip to transmission energisation process dependent on switching plan]	N/A	N/A	N/A	N/A
Instruct energisation to point of demand connection	NGESO	N/A	NGESO, DNO	Yes
Energise to point of demand connection	DNO	DNO	DNO, DERs	Yes
Forecast demand pick-up at primary substation	NGESO	DNO	DNO, NGESO	Yes
Implement demand changeover-process to reduce block load size to manageable power island capability (see section 10 DRZC)	DNO	DNO	DNO, NGESO, Flexible demand, DER	Yes
Complete DRZ switching plan to introduce circuit redundancy as applicable	DNO	DNO	DNO	Yes

7.9.7 Break point

This represents a potential break point in the DRZ plan. If it is not technically possible or economic to achieve outward energisation of the network to the point of synchronisation to another power island or auxiliary supply for another energy resource, a DRZ may be used for the purpose of supplying local demand only. Depending

on the most economical solution, new 33kV synchro-check relay or existing 132kV synchro-check relays would enable reconnection after transmission restoration is achieved through conventional Black Start capability. This would enable demand restoration timelines to be significantly cut through the implementation of multiple local DRZ islanding schemes.

Table 7.8

Break point key actions and responsibilities

Action	NGESO led owner	DNO led owner	Parties involved	Included in DRZC scope
For a plan where this represents the end point, the following process applies; for all others, skip to incorporation into national strategy	N/A	N/A	N/A	N/A
Confirm readiness of 132kV network to synchronise to 33kV power island	NGESO	DNO	NGESO, STO, DNO	No
Instruct energisation to the point of synchronisation	NGESO	N/A	NGESO, TO, DNO	No
Arm synchronising circuit breaker	TO/DNO	TO/DNO	TO, DNO	No
Skip to end of DRZ process				

7.9.8 Incorporation into national Black Start strategy

Using the existing national strategy and any further information on the actual capability range of the DRZ, the DNO and NGENSO will work collaboratively to determine the most effective contribution the DRZ can make to national restoration. In this illustrative example, they may either energise the 275kV network, energise the 400kV network or

restore further distribution level supplies at 132kV. The choice will depend upon transmission network readiness, transmission connected provider availability and the intended synchronisation point. Each DRZ will have a set of associated transmission restoration procedures equivalent to the options included within an LJRP.

Figure 7.10

Indicative DRZ strategic growth options for incorporation into national strategy (highlighted sections are to be considered energised)

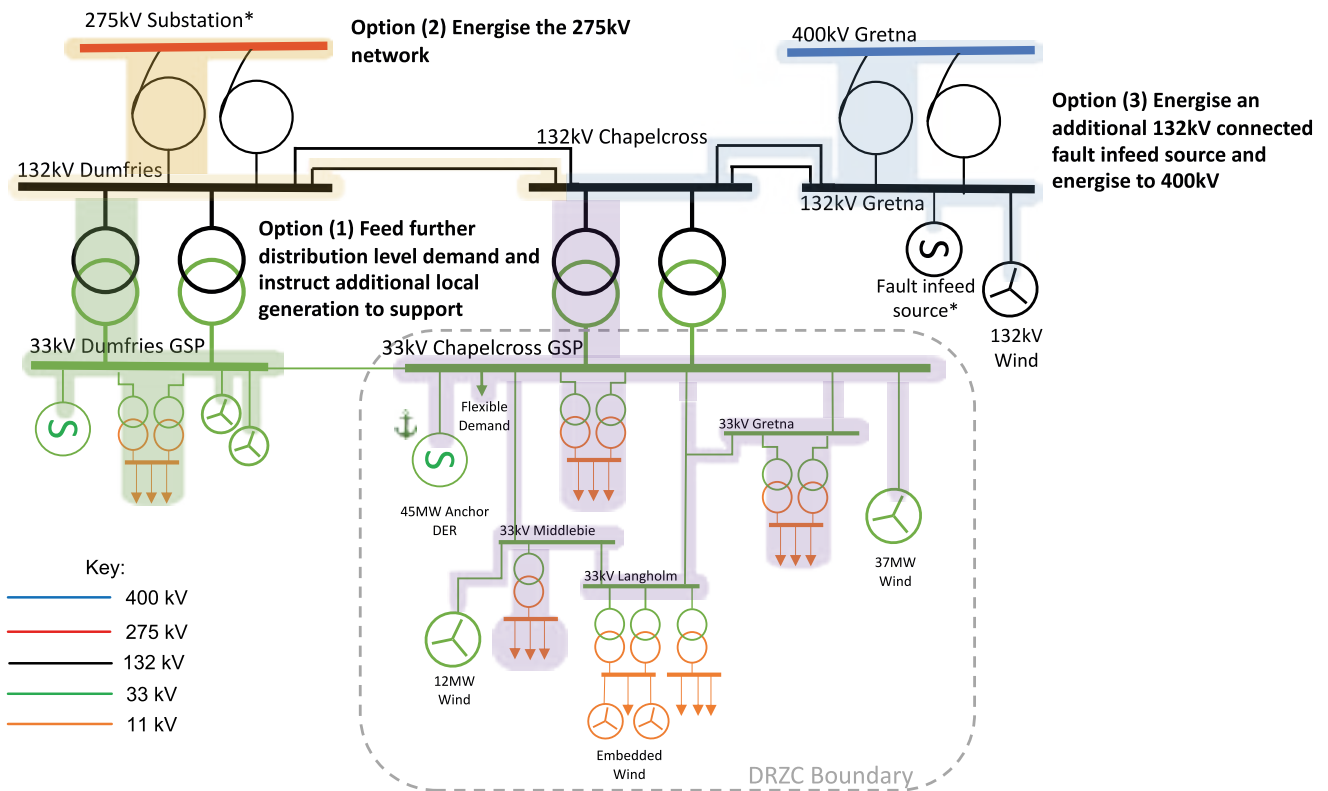

Table 7.9

Incorporation into national strategy key actions and responsibilities

Action	NGESO led owner	DNO led owner	Parties involved	Included in DRZC scope
Review availability of transmission and distribution connected energy resources and select restoration option	NGESO	DNO	NGESO, DNO	N/A
Instruct further distribution power island growth	NGESO	DNO	NGESO, DNO	No
Instruct 275kV or 132kV transmission network energisation process	NGESO	NGESO	NGESO, DNO, TO	No
Instruct 400kV energisation process	NGESO	NGESO	NGESO, DNO, TO	No

7.9.9 Further distribution power island growth

A key finding of the power systems modelling is that the thermal capacity of 33kV interconnection is typically unsuited to support demand or generation restoration [1], therefore restoring supplies to these customers can be achieved through 132kV energisation and the downward energisation of 132kV/33kV transformers. The energisation of auxiliaries to additional DERs may enable them to provide supplies to further local energy resources but unless contracted it may not be possible to utilise these resources as not

all DER are currently obligated to follow emergency instruction protocols from NGENSO or DNOs. For the purpose of this report, we consider these resources to be dispatchable once communications have been restored to the control point. NGENSO will instruct additional DERs to synchronise to the distribution network and provide setpoint instructions that limit the risk from stochastic energy resources. After this stage is executed, we return to the “incorporate into national strategy” stage and repeat this process of transmission or distribution system growth.

Table 7.10

Further distribution power island growth key actions and responsibilities

Action	NGESO led owner	DNO led owner	Parties involved	Included in DRZC scope
Energise to the point of non-DRZ demand or generation connection	DNO	DNO	NGESO, DNO	N/A
Instruct generation to synchronise at agreed power and reactive power setpoint	NGESO	DNO	NGESO, DNO	No
Forecast primary demand	NGESO	DNO	DNO	No
If primary demand exceeds step change capability of the DRZ and additional connected resources, conduct demand changeover process, otherwise energise demand	DNO	DNO	DNO, Flexible demand	No

7.9.10 132kV or 275kV energisation

Where the strategy is to energise the 132kV or 275kV transmission network, the DNO should energise to the point of transmission connection.

NGESO will confirm the readiness of all parties and instruct the transmission restoration option to the TO associated with

the DRZ. This may be the point of connection to a transmission connected energy resource’s auxiliaries or the remote point of synchronisation to another power island. Given the requirement to assure safety across this process, the TO and DNO will briefly coordinate with each other as the 132kV/275kV transformer is energised.

Table 7.11

Transmission energisation key actions and responsibilities

Action	NGESO led owner	DNO led owner	Parties involved	Included in DRZC scope
Energise to the point of 132kV/275kV energisation	DNO/TO	DNO/TO	DNO, TO	No
Confirm readiness to energise transmission system	NGESO	NGESO	NGESO, TO, DNO	No
Direct TO/DNO comms for safety, energise to 132kV/275kV	TO	TO	TO, DNO	No
Return to incorporate into national strategy stage				

7.9.11 400kV energisation

OST has identified that energising the 400kV network requires a 132kV or 275kV connected fault infeed source to provide sufficient fault current to operate protection systems. This means the first stage of 400kV energisation is to energise to the point of connection of the fault infeed source.

In addition to these core service providers, any 132kV connected balancing mechanism unit (BMU) that has communications restored may now be emergency instructed under the provisions of Grid Code OC9 by the Electricity

System Operator, potentially enabling a greater 400kV circuit distance to be energised.

NGESO will confirm the readiness of all parties and instruct the transmission restoration option to the TO associated with the DRZ. This may be the point of connection to a transmission connected energy resource’s auxiliaries or the remote point of synchronisation to another power island. Given the requirement to assure safety across this process, the TO and DNO will briefly coordinate with each other as the 132kV/400kV transformer is energised.

Table 7.12

Transmission energisation key actions and responsibilities

Action	NGESO led owner	DNO led owner	Parties involved	Included in DRZC scope
Instruct energisation to the point of 132kV fault infeed source	NGESO	N/A	NGESO, DNO	No
Energise to the point of 132kV fault infeed source	DNO/TO	DNO/TO	DNO	No
Instruct 132kV fault infeed source to synchronise to the power island	NGESO	DNO	NGESO, DNO, DER	No
Energise to the point of 132kV/400kV energisation	DNO/TO	DNO/TO	DNO, TO	No
Confirm readiness to energise transmission system	NGESO	NGESO	NGESO, TO, DNO	No
Energise to 400kV	TO	TO	TO, DNO	No
Return to incorporate into national strategy stage				

7.9.12 End of a DRZ

There are three end conditions for the DRZ control and communications interfaces.

- (1) Synchronisation to another transmission level power island provided through any source (inclusive of another DRZ).
- (2) Connection of demand outside of the DNO licence area.
- (3) Connection to a non-contracted transmission level energy resource.

When this end condition is reached, the power island will no longer be treated as a virtual provider with outputs intended

to be delivered at the 33kV/132kV interface. All machines will be set to a response mode where possible and stochastically available generation will be instructed to operate at no greater than a specific threshold which is considered reliable for an appropriate period of time. Regardless of model implemented, NGESO will become the frequency leader for the power island and conventional Black Start communication and control interfaces will be re-established. No further process is defined because the post-LJRP stages of conventional Black Start will apply from this point onwards. This does not represent the end of Black Start until the Power Systems Manager from NGESO declares the 33kV/132kV interface end of Black Start.

Table 7.13

End of a DRZ key actions and responsibilities

Action	NGESO led owner	DNO led owner	Parties involved	Included in DRZC scope
Instruct transmission network energisation to point of synchronisation	NGESO	NGESO	NGESO, TO	No
Energise to point of synchronisation	TO	TO	TO, DNO or NGESO	No
Instruct synchronisation	NGESO	NGESO	NGESO, DNO, TO or Generator	No
End of the DRZ control and communications interfaces, NGESO is now frequency leader for all models	NGESO	NGESO	All	Yes, mode change on DRZC expected

7.10 Model risk analysis

Each organisational model has relative merits and risks. A manual process will have lower capital implementation costs, due to lesser requirements on systems, but automation enables faster restoration and reduces the headcount burden.

The organisation acting as the lead control entity also influences the level of risk held through changing the operational interfaces and processes. This section reviews the organisational models against key risk factors associated with the existing Black Start process to demonstrate the change in risk introduced from Distributed ReStart.

Each organisational model is provided with a RAG status indicative of the expected change in risk from the current Black Start process.

Table 7.14
Risk categories

RAG indicator
Unacceptable risk introduced
Additional risk introduced
No change in risk from conventional Black Start
A reduction in risk from present Black Start

7.10.1 Service delivery risk

A Black Start process must deliver a highly reliable technical solution and operational procedure for restoring supplies. The following table reviews this operational risk against the proposed organisational models and finds that there is opportunity for Distributed ReStart to reduce the risk through

enhanced diversification of Black Start methodology and, where automated, removing external influencers from the technically optimal restoration process. A mitigation which is required to achieve this benefit is manual processes to act as redundancy in the event of automation failure.

Table 7.15
Service delivery risks

Process model	Relative risk compared with conventional Black Start
Model A (NGESO automated)	An automated process decreases the relative risk where a working manual process exists for the purpose of redundancy. Automation removes external influence from the technical procedure and removes human error. In addition, the technical risk is reduced due to the capability to implement very fast control of loads.
Model B (NGESO manual)	A manual process keeps the level of risk the same as the existing process. After training and skillsets are built, pre-defined procedures can be executed using a strategy that meets the current network needs. Due to the increased complexity, there is a higher risk of failure for each individual plan; however, due to the increased number of plans, the overall technical delivery risk remains the same.
Model C (DNO automated)	An automated process decreases the relative risk where a working manual process exists for the purpose of redundancy. Automation removes external influence from the technical procedure and removes human error. In addition, the technical risk is reduced due to the capability to implement very fast control of loads. As the strategic control and automation platforms are distributed regionally across the DNOs this provides diversity and redundancy for national restoration.
Model D (DNO manual)	A manual process keeps the level of risk the same as the existing process. After training and skillsets are built, pre-defined procedures can be executed using a strategy that meets the current network needs. Due to the increased complexity, there is a higher risk of failure for each individual plan; however, due to the increased number of plans, the overall technical delivery risk remains the same. As the strategic control function is distributed regionally this leads to diversity in approach which will provide redundancy but still require close coordination with NGESO to incorporate into national strategy.

7.10.2 End-to-end technical assurance risk

The whole electricity industry works collaboratively to ensure there is an extremely low risk of a Black Start situation. For this reason, it is likely that most plans are never used. This creates a high dependency on effective technical assurance to ensure that plans are monitored for availability and remain technically capable of delivering the contracted service. The following table demonstrates that due to the increased number of participants and the increased

dependency on resource coordination, the existing technical assurance framework increases the risk that assurance is not effectively delivered. However, automation provides an opportunity to increase the visibility of real-time availability for both commercial and assurance purposes. Furthermore, effective real-time digital simulation (RTDS) modelling provides an option to test the operational procedure and automation response, giving opportunity to assure the end-to-end service.

Table 7.16
Assurance risks

Process model	Relative risk compared with conventional Black Start
Model A (NGESO automated)	An automated process decreases the relative risk associated with assurance of Black Start plans. The DRZ controller will require online monitoring for availability of networks and energy resources. It is anticipated that this data will be able to report availability to NGESO and DNO control rooms, introducing real-time assurance and availability monitoring. Whilst end-to-end testing of the automated platform will not be possible without impacting on customers, hardware in the loop testing through real-time digital simulation models can be used to demonstrate the suitability of the plan, providing an option for greater assurance than is possible for conventional Black Start.
Model B (NGESO manual)	A manual process will increase the relative risk of assurance due to the larger number of energy resources which need to be tested. It is unlikely that the full end-to-end process of establishing a power island is able to be tested due to impact on customers supplies, further increasing the cost and complexity of assurance.
Model C (DNO automated)	An automated process decreases the relative risk associated with assurance of Black Start plans. The DRZ controller will require online monitoring for availability of networks and energy resources. It is anticipated that this data will be able to report availability to NGESO and DNO control rooms, introducing real-time assurance and availability monitoring. Whilst end-to-end testing of the automated platform will not be possible without impacting on customers, hardware in the loop testing through real-time digital simulation models can be used to demonstrate the suitability of the plan, providing an option for greater assurance than is possible for conventional Black Start.
Model D (DNO manual)	A manual process will increase the relative risk of assurance due to the larger number of energy resources which need to be tested. It is unlikely that the full end-to-end process of establishing a power island is able to be tested due to impact on customers supplies, further increasing the cost and complexity of assurance.

7.10.3 Organisational risk

There is a risk that organisations are not prepared for a Black Start event given its very low probability. The existing process relies on NGESO's 24 hour operational readiness but anticipates self-starting and call-in resources across other organisations. Where a plan cannot be executed using the minimum staffing level, there is a risk that organisations are not able to deliver against forecast timelines. As Distributed

ReStart increases the number of Black Start plans available and increases the coordination complexity, additional organisational risk is introduced. However, automation can reduce the staff requirement to levels manageable under existing resources without reliance on call-in procedures and distribution of responsibility has potential to mitigate against the increased operational risk of more complex plans.

Table 7.17
Organisational risks

Process model	Relative risk compared with conventional Black Start
Model A (NGESO automated)	An automated process does not change the level of organisational risk held. It is anticipated, based upon the organisational review, that the need can be met with minimal changes to control engineer requirements to standard operations within NGESO and DNOs. Where a DER does not have automated start-up procedures, a requirement for 24 hour minimum staffing could be introduced for parties with a contract to ensure this low level of risk is held across all entities involved.
Model B (NGESO manual)	A manual process introduces additional organisational risk through creating a resource requirement that is not possible to be met using normal staffing requirements. As most NGESO control engineer roles are already staffed 24 hours this means that additional people will require Black Start training and that a new reliance on call-in or self-starting control staff will be introduced.
Model C (DNO automated)	The organisational risk remains the same or potentially reduces slightly as it is anticipated that minimum staffing levels will be capable of monitoring and control of multiple DRZCs. However, in a scenario where additional people are needed to deliver against Distributed ReStart requirements, this aligns with the existing process rather than introducing new risk.
Model D (DNO manual)	A manual process enacted by DNOs does not change the level of organisational risk held. Whilst this still requires additional resources to deliver against a plan compared with standard operations, DNOs already rely on self-starting policies for Black Start meaning whilst there is a greater number of resources required, no additional risk is introduced through this method.

7.10.4 Systems risk

There is a risk that introducing new telephony or control systems increases vulnerability of the Black Start procedure to system failure or cyber breaches. Extensive work is being conducted across cyber security and telecommunications to ensure this enhanced risk is mitigated but as more data

points and greater reliance on automation are introduced, so the risk associated with systems failure increases. Manual procedures are defined for both NGESO and DNO led models to mitigate this risk and control systems inclusive of telephony are specified to have extremely high availability.

Table 7.18
Systems risks

Process model	Relative risk compared with conventional Black Start
Model A (NGESO automated)	Automated systems have increased telecommunication and systems requirements risk compared with existing Black Start. Some of this risk is mitigated through a manual back-up procedure but there are additional nodes to provide cyber secure telecommunications compared with manual processes. See section 15.
Model B (NGESO manual)	A manual NGESO led process introduces new telecommunication and systems risks because it requires complete situational awareness of the distribution networks and DERs. This enhanced communications requirement introduces new cyber security vulnerabilities. See section 15.
Model C (DNO automated)	Automated systems have increased telecommunication and systems requirements risk compared with existing Black Start. Some of this risk is mitigated through a manual back-up procedure but there are additional nodes to provide cyber secure telecommunications compared with manual processes. See section 15.
Model D (DNO manual)	A manual DNO led process will keep a similar degree of systems and telecommunications risk to present Black Start. Rigorous cyber security protocols are required but most communications interfaces introduced with DERs are comparable to existing ANM schemes. Direct control.

7.10.5 Restoration timescale risk

There is a risk that the expected demand restoration timelines – due for publication in the Black Start Standard – cannot be met where a Black Start is delivered through DERs. It is shown that automated procedures enhance the speed for customer connection under both models; however, the additional complexity and competing resource

requirements under the NGESO led manual procedure increases the risk. There is potential for the DNO led procedure to utilise non-committed resources outside of the conventional block loading procedure to connect customers at distribution level, maintaining a similar restoration timeline to conventional Black Start.

Table 7.19
Restoration time risks

Process model	Relative risk compared with conventional Black Start
Model A (NGESO automated)	Under an NGESO led automated process there is a decrease to the risk that Black Start does not meet demand restoration timelines. It is anticipated that the process will enable demand to be supplied more quickly than present Black Start, however contribution to wider network energisation may take longer due to the decreased resource scale.
Model B (NGESO manual)	An NGESO led manual process will deliver lower Black Start costs but will increase the risk to demand restoration timelines. It is anticipated that a manual process will take longer to execute than existing Black Start. It is anticipated that demand will be restored more quickly but due to the complexity of wider network energisation there is a risk that overall demand restoration timelines are not met.
Model C (DNO automated)	Under a DNO led automated process there is a substantial decrease to the risk that Black Start does not meet demand restoration timelines. It is anticipated that the DNO may be able to execute a plan separately from existing LJRPs across the initial stage due to the lack of competing resource. This will support faster demand restoration enabling plans to be in a state of readiness.
Model D (DNO manual)	A DNO led manual process will not change the overall risk to Black Start demand restoration timelines. Demand can be supplied through starting plans locally without drawing on the resources required for conventional plans during early stages. However, incorporation into transmission level plans will be more complex due to the control of smaller energy resources.

7.10.6 Procurement efficiency risk

There is no change to the procurement risk associated with any organisational model. A legal review has demonstrated that the lead purchaser can be disassociated from the technical coordinator role. This means the most effective buyer can be used across all models. The specific challenges and options for procurement are discussed in the complementary Procurement and Compliance report.

7.11 Conclusion

Stakeholder consultation to date has demonstrated both a willingness and appetite for DNOs to take on an enhanced role within the restoration process. However, it has also demonstrated that national leadership from NGENSO remains a key factor in the effectiveness of plan delivery. A simple command and control model with a single lead party under all circumstances does not enable the most effective delivery of Black Start due to unnecessary delays through additional information exchange that does not add value. A strong collaborative effort across the parties provides an effective process.

The design process aimed to eliminate as many inefficiencies as possible through the creation of full process maps for both DNO and NGENSO led procedures and evaluating

their overall efficiency in terms of execution time and staff requirements. From this analysis it was found that the DNO led procedure was substantially more efficient up to the point of transmission network energisation, while the NGENSO led procedure was substantially more efficient with regards to integration into the wider transmission level plan. As a result, specific tasks were re-allocated, and the command and control structures were reviewed to enable a process by which the DNO leads locally and NGENSO leads nationally with an overall collaborative command and control structure being implemented. This aligns with wider industry work on the Distribution System Operator model and leverages the capabilities of individual organisations.

This collaborative control methodology is discussed in detail in section 8 and is shown to optimise the overall restoration process.



8.1 Proposed control model

Through the design stage analysis, we have developed a collaborative control proposal that focuses on:

- local leadership from DNOs, leveraging their existing network expertise and control systems capability; and
- national leadership from NGESO, leveraging its greater national situational awareness and enabling a consistent national approach to restoration.

This provides for NGESO assuming responsibility for instructing the start of a DRZ. The exception to this being cases when a DRZ can be independently sustained without access to the transmission system for the expected overall GB restoration timeline i.e. it does not have fuel/storage constraints or a reliance on non-dispatchable energy resources. This will enable the start of time constrained plans to be optimised against wider national availability and strategy, but unlock the time efficiency of starting the plans ahead of full national information gathering wherever practical.

After plan instruction, the DNOs remain responsible for the DRZ. The DRZ will have pre-agreed contractual boundaries and all actions within this zone will be instigated by the DNO. It is noted that, due to the possibility that a DRZ may require 132kV network assets in order to connect DER and demand, there may be instances where a DRZ includes part of the transmission network in Scotland. If this situation should occur, the Scottish TO should be responsible for the DRZ. Due to the joint transmission and distribution control centre, this means it should be supervised by an engineer with transmission control authorisation.

Outside of the DRZ, all actions at 132kV or above will be the responsibility of NGESO. They will instruct the respective TO or DNO to continue the restoration process in line with overall national strategy. This will include emergency instruction of non-contracted resources at 132kV and above in order to enable overall restoration. Where strategy is to continue to grow the distribution network through interconnection, this should include an option to emergency instruct DERs but this will require code change to facilitate and is being progressed by the Procurement and Compliance workstream.

Figure 8.1
Central model process flow

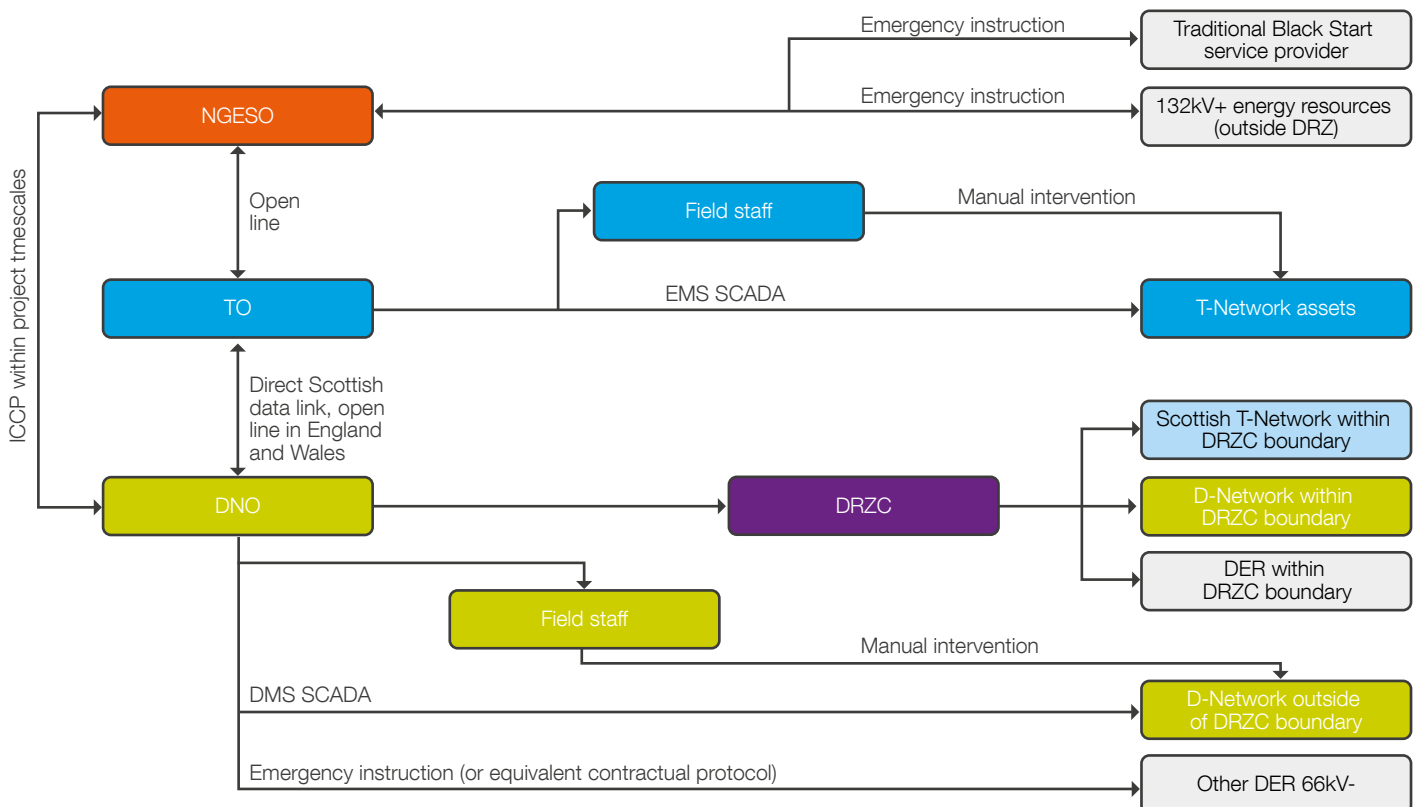

8.2 Task allocation

Table 8.1

Table demonstrating the operational responsibilities across organisations under the proposed organisational model

Action	Responsible under current Black Start	Responsible control entity
Declare Black Start	NGESO	NGESO
Responsible for national strategy	NGESO	NGESO
Responsible for regional strategy	NGESO/Scottish TO	NGESO
Instruct start of plan	NGESO/Scottish TO	NGESO/Scottish TO, only withheld where a DRZ requires access to the transmission system to sustain supplies for an extended period
Instruct start of Anchor DER	N/A	DNO
Instruct transmission switching actions	NGESO	NGESO
Physical transmission network actions	TO	TO
Physical distribution network actions	DNO	DNO
Physical actions of contracted generation	Black Start provider (or virtual lead party)	Multiple individual providers
Instruct DRZ energisation route	N/A	DNO/Scottish TO ¹
Instruct growth option outside of DRZ boundary	N/A	NGESO
Instruct DERs within a DRZ	N/A	DNO/Scottish TO ¹
Instruct DERs outside of DRZ boundary	NGESO where Black Start provider	NGESO
Instruct non-contracted DERs (emergency instruction equivalent procedure)	NGESO through DNO (clarified through GC0143)	NGESO via DNO instruction
Manage overall distribution power island voltage and frequency	N/A	DNO are frequency lead until synchronisation with an energy resource or demand outside of the DRZ

8.3 Process map

The following process map provides a detailed task allocation and communications interface diagram across all process stages. Furthermore, indicative organisational requirements are shown for the manual base case for executing a single DRZ. Whilst the overall process assumes that a DRZC is implemented, these serve to provide the command and control structure and procedures to follow in the event of automation failure or for initial pre DRZC roll-out.

All actions are categorised as:

- strategy;
- electrical actions;
- information; or
- instruction.

In addition, all steps which are included in the DRZC scope are highlighted through use of a pink border.

In addition, indicative information is provided against the following categories:

- operational telecommunications speed requirements;
- communications requirements, the difficulty and value from automation;
- the indicative time taken for an action to be completed;
- the number of people expected to be required for each step;
- the anticipated training requirement; and
- the code change expectation.

Collectively these variables define the efficacy of a plan and provide a baseline to be tested through refine stage desktop exercises.

¹ A DRZ may span sections of 132kV network inclusive of 132kV energy resources, in Scotland this is a transmission voltage meaning that the TO function would assume overall plan responsibility from the DNO post 132kV energisation.

Distributed ReStart process map

This process map contains indicative information across all key elements of the process and organisational design. This will be refined through desktop exercises and further engagement with potential Distributed ReStart participants.

Figure 8.2
Process key

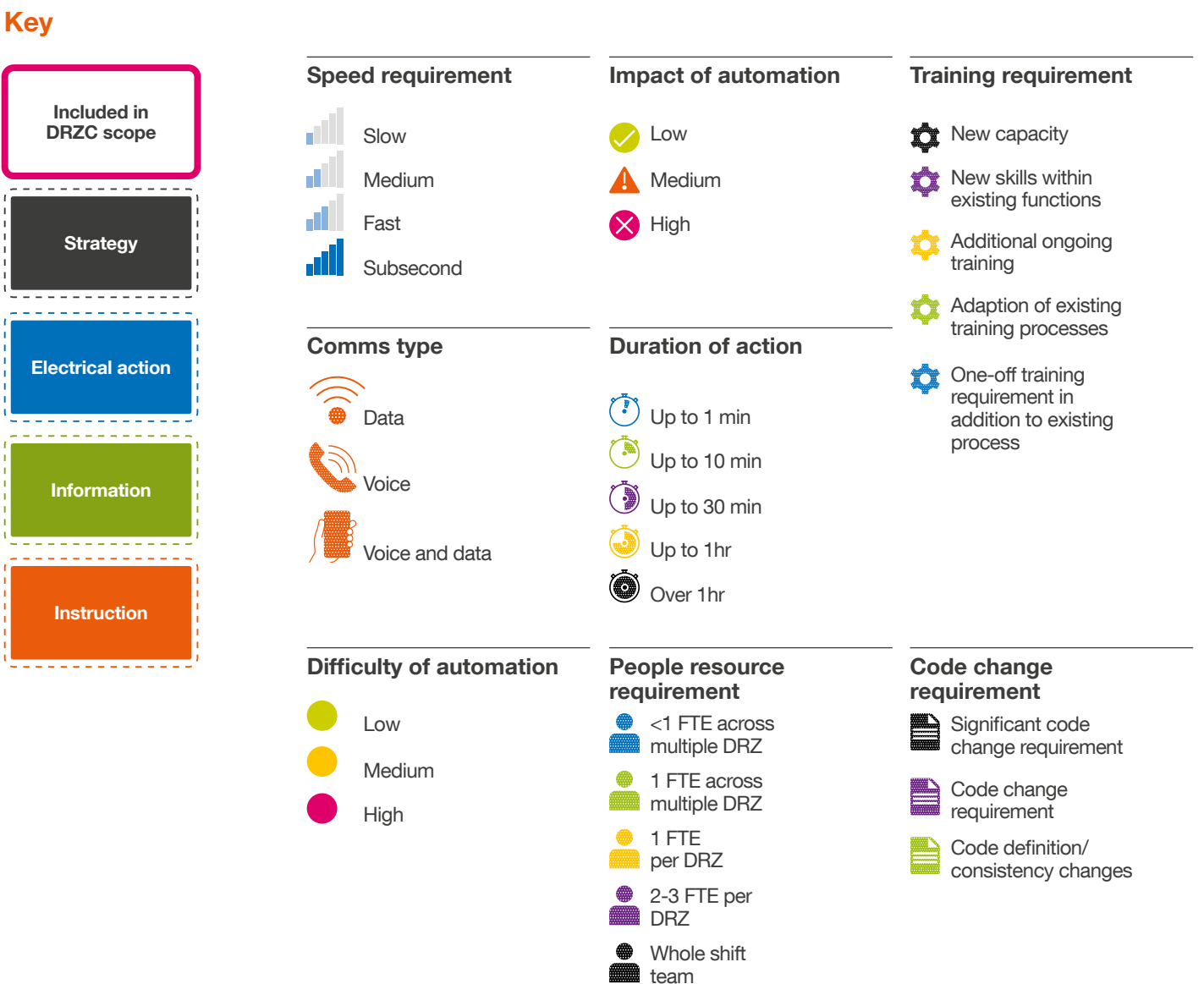

Distributed ReStart process map

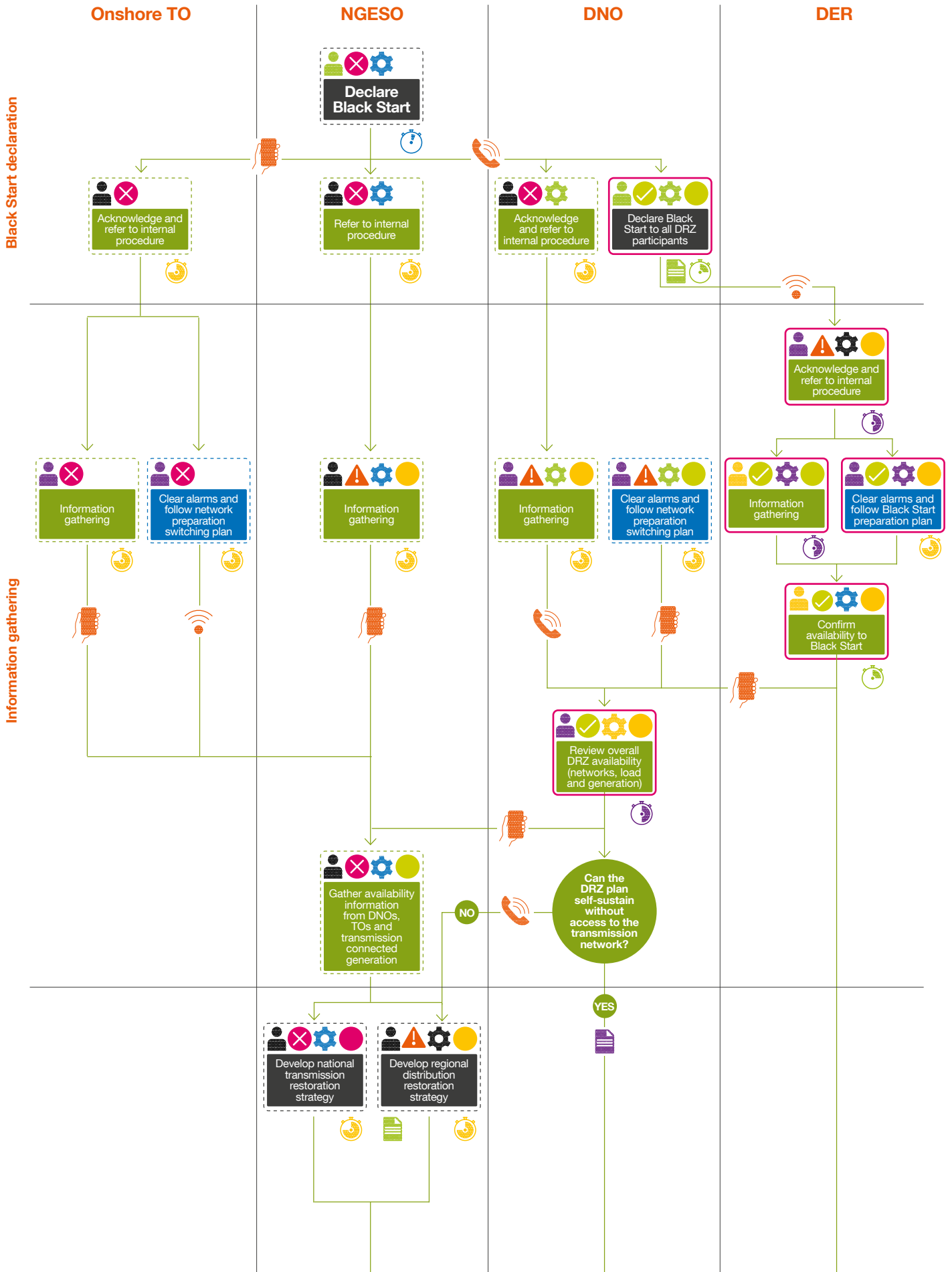

Distributed ReStart process map

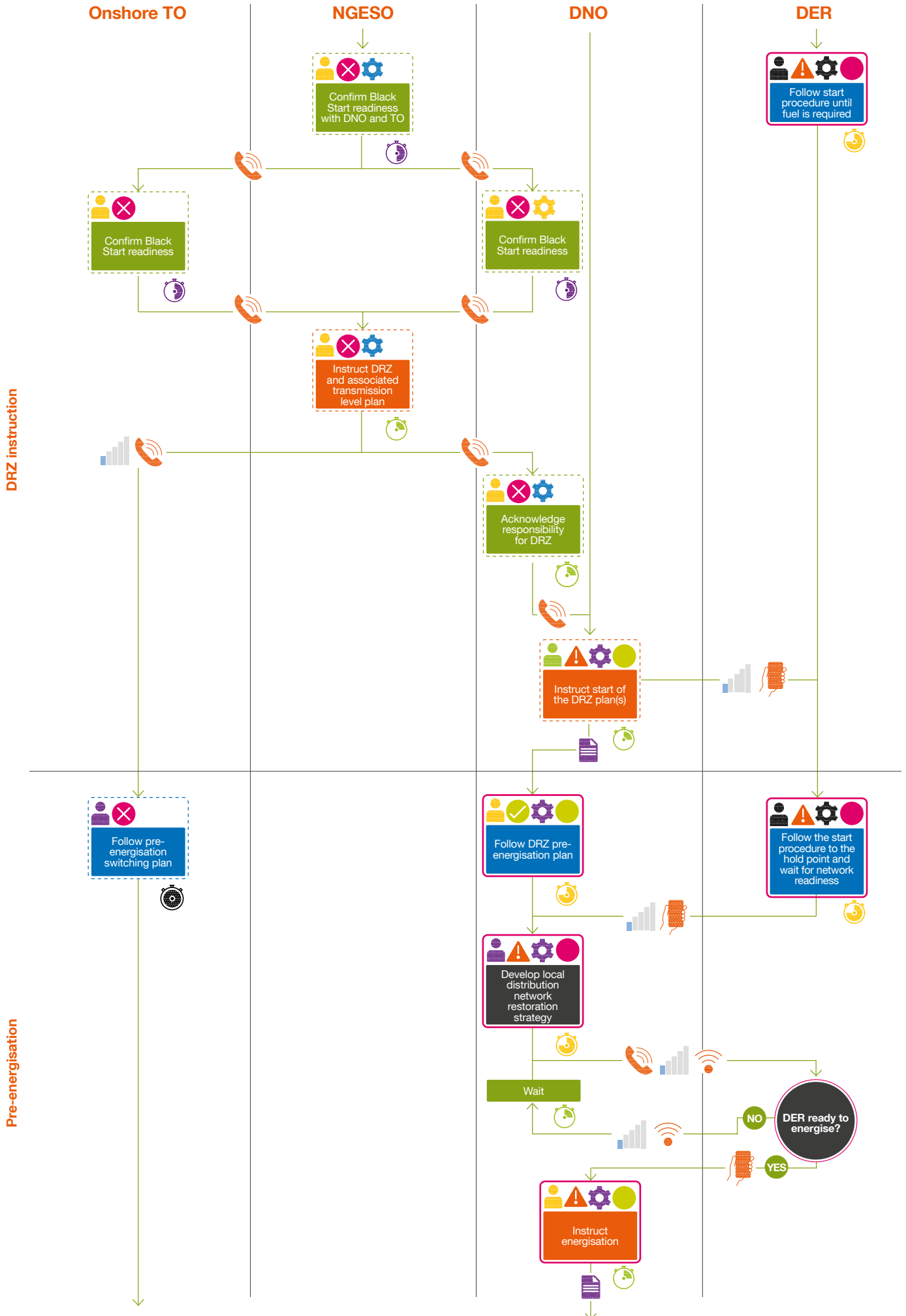

Distributed ReStart process map

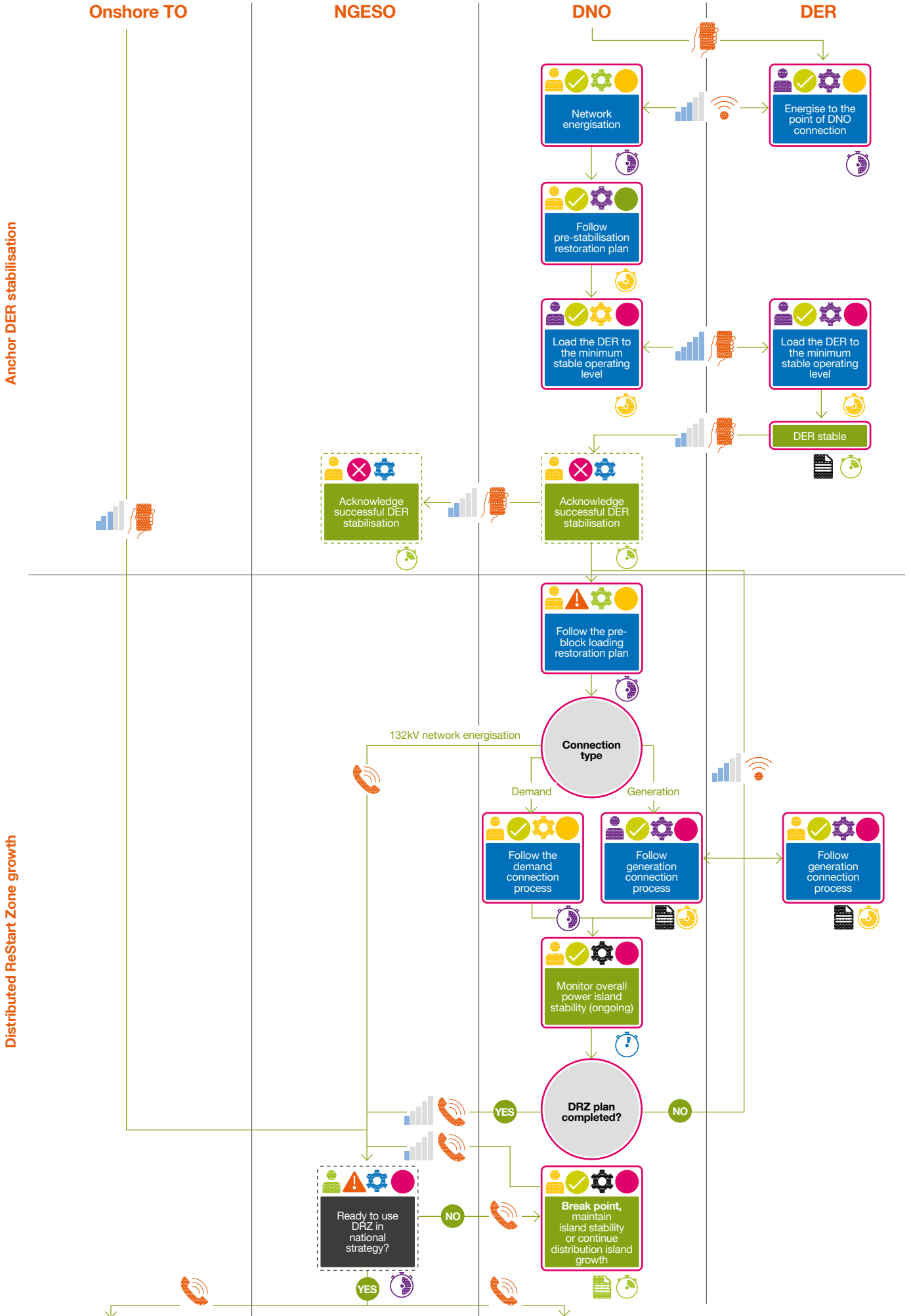

Distributed ReStart process map

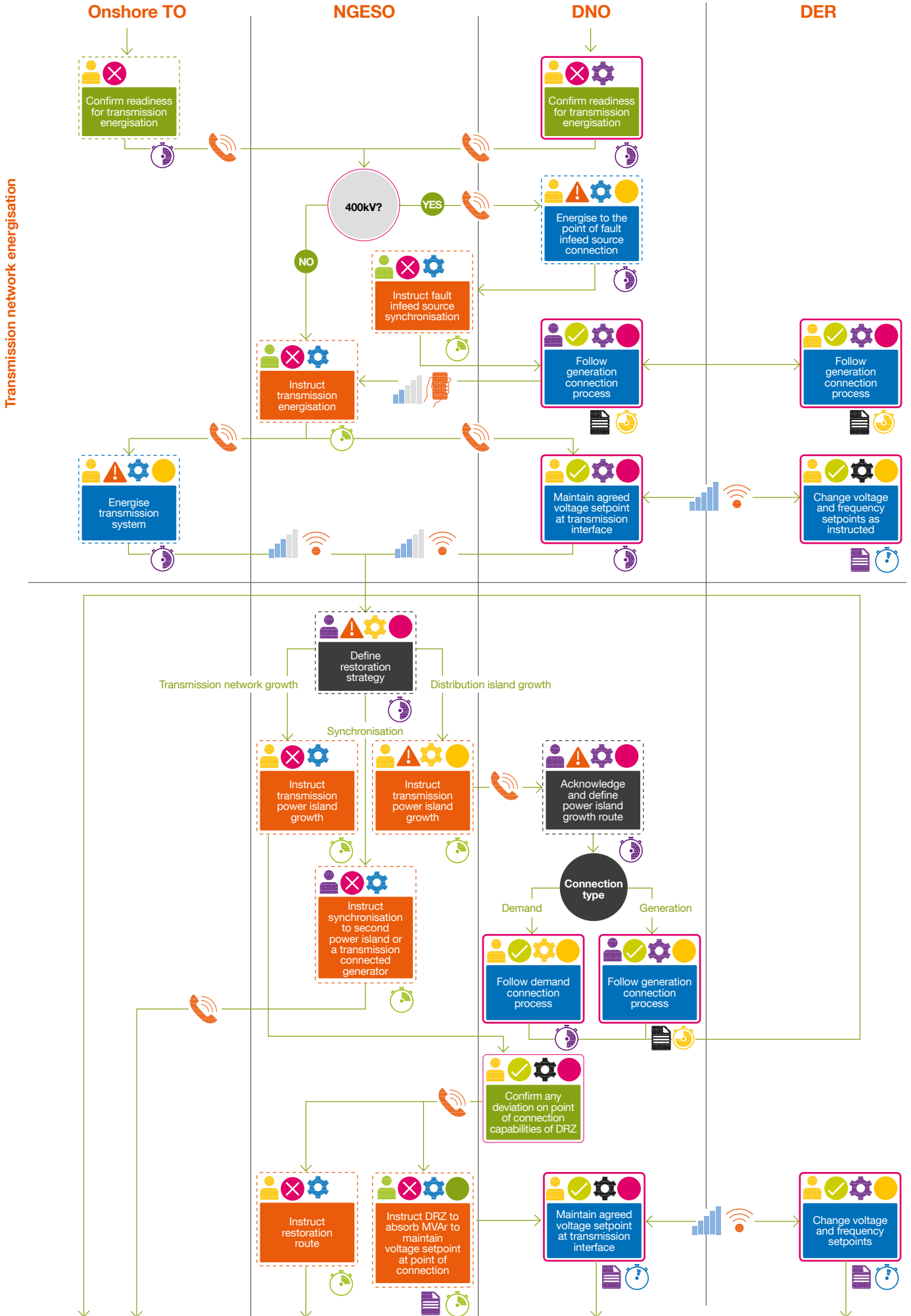

Distributed ReStart process map

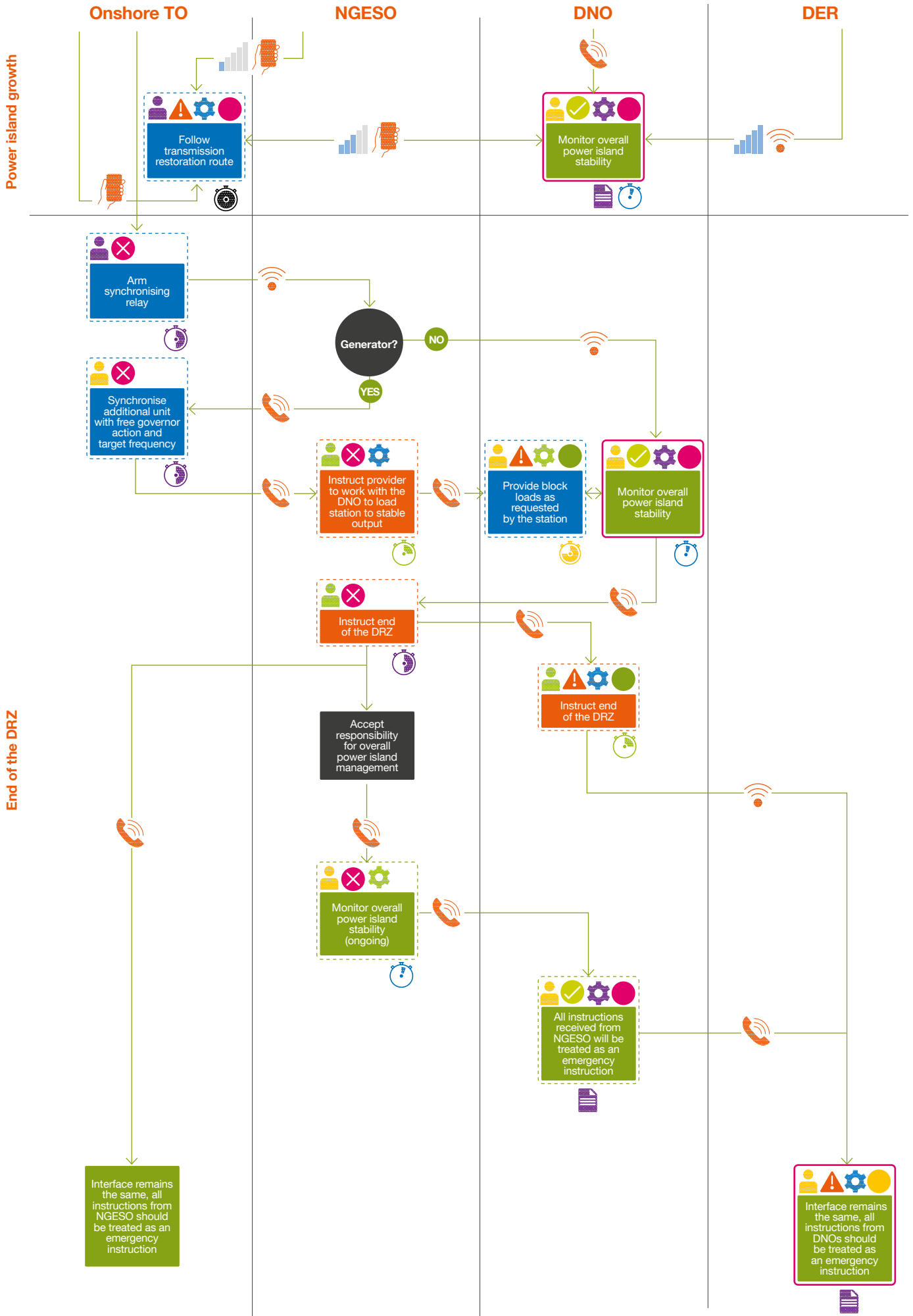



9.1 Introduction

The project has identified the need for a degree of automation to be introduced to reduce the workforce burden and mitigate against power engineering risks. This introduces the need for a DRZC. The objective of this control scheme is to establish a power island at a grid supply point with an appropriate workflow to enable initial energisation, connection and dispatch of DERs, and restoration of local

demand. Once the power island is established, the goal would be to harness the collective capabilities of the Anchor DER, other DER providing support services, and flexible demand to maintain stability and provide an aggregated capability at the point of connection to support wider network restoration.

Figure 9.1

Conceptual DRZC architecture, note this is indicative of design proposals but not all elements are included in all design proposals

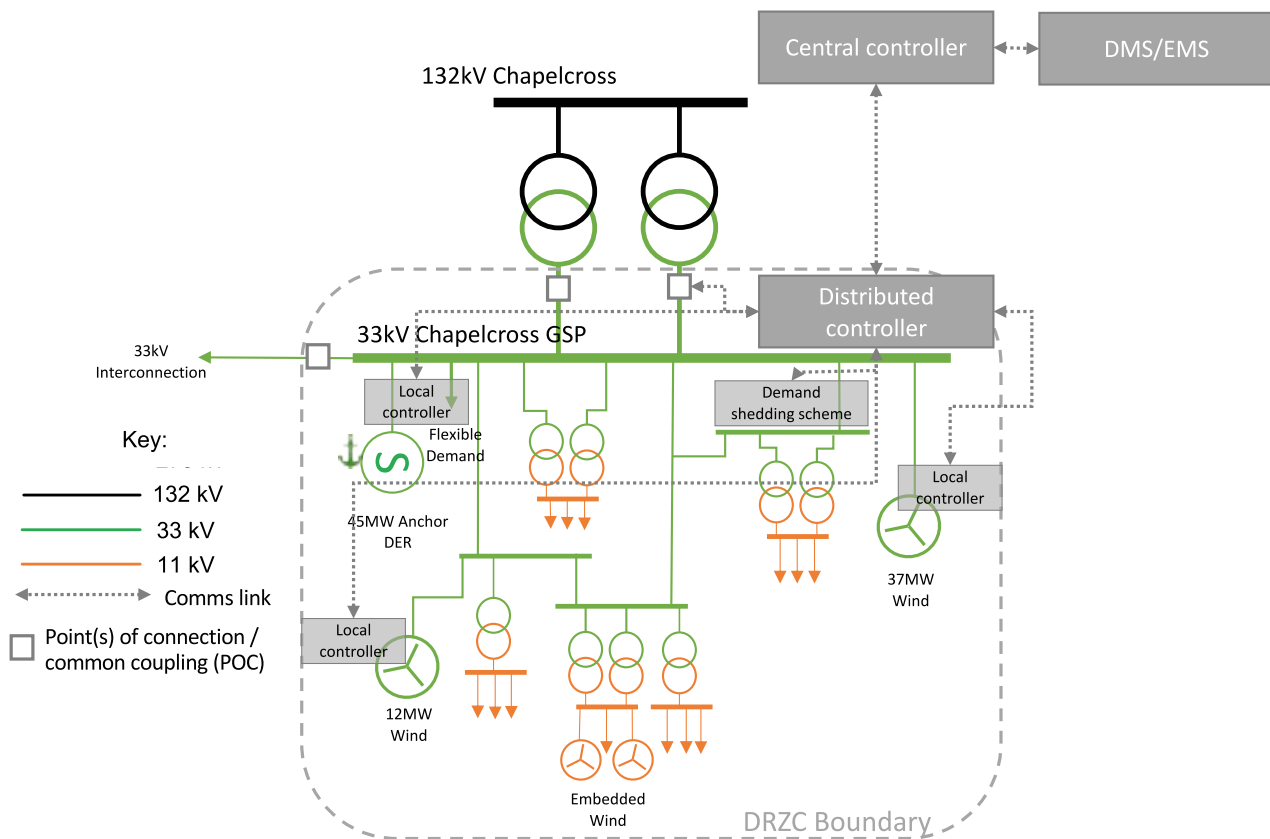

Full design proposals will be discussed in a later Distributed ReStart publication, but a high-level overview of the conceptual process and design is provided in this section as context for the operational telecommunications requirements and proposed organisational structures.

9.2 Control system requirements

It is anticipated that a DRZC will be capable of executing the following actions to establish and maintain a stable distribution power island:

- Operating within pre-configured bounds in terms of the DER available for control and the energisation paths available to be used, identify the feasible and preferred courses of action and either implement them directly or provide control engineers with the information they require to implement each step.
- Manage available resources and control actions to maintain acceptable levels of risk in terms of power island stability and reenergisation.
- Constantly review the individual and collective capability of connected resources to maintain their individual stability and availability, support the anchor generator and power island, re-connect customers, manage variability in demand and generation, and support further network reenergisation.
- Provide fast-acting response to demand and generation changes, faults or forecast errors.
- Enhance the power island block loading capability through flexible demand solutions (multiple technologies have been considered to provide recommendations on control methodologies that enable incorporation into the design).

Post power island stabilisation, the control scheme should be capable of collating the capabilities of individual DERs to release additional power and reactive power capacity to the wider network at the point of connection.

9.3 Conceptual architecture

The project has commissioned DRZ designs from leading micro-grid and ANM scheme developers. A detailed report covering the outcomes of these various designs and proprietary hardware implementations will be provided in the Power Engineering and Trials Requirements report due for publication in December 2020. This section discusses the common elements across all designs to the extent that is required for overall system design and telecommunications requirements.

9.3.1 Controller elements

There are three proposed levels at which control schemes could be implemented, and all designs use at least two of these levels.

Centralised controller

The centralised controller interfaces directly with the distribution management system (DMS) and/or the energy management system (EMS) dependent upon the organisational model used. An ICCP may be used for data exchange between these systems enabling direct mapping of data points and feedback of controller actions through business as usual interfaces or human machine interfaces (HMI) which are bespoke for the restoration process. It is expected that SCADA data and control engineer inputs will be used to conduct all decision-making activities and issue instructions to execute 'slow' control processes such as DER ramp-up or curtailment due to weather conditions or requested point of connection setpoints. It is expected that the centralised controller will be located at the DNO

or NGENSO control room data centre. Where multiple DRZCs are implemented across the country, the DNO/NGESO control room data centre will coordinate the actions of these controllers and execute data intensive processes which do not need fast response such as demand and intermittent DER output forecasting. To facilitate the proposed collaborative control model would mean having central controllers at each DNO control room where applicable to the DRZC design.

Distributed controller

A distributed controller is present in some designs for the DRZC. This would be located at the GSP and coordinate the actions of individual DERs. The advantage of distributing the coordination role is that lower latency communications can be achieved, and shorter route distances are required for low latency communications. 'Fast' control processes that rely on multiple DER or demand changes would be calculated and instructed at this level in reference to centralised controller instructions or changes observed at a local level. This system requires low latency communications with local controllers but can use existing SCADA or other higher latency communications with the centralised controller to provide feedback to the control room on actions taken and to accept strategic instructions.

Local controller

A local controller is situated at the DER site and interfaces directly with its remote terminal unit (RTU) or similar controller. This enables responses such as droop control, P/Q dispatch or virtual power plant modes to be emulated directly without change to the DER internal control scheme. This allows for very fast response such as frequency or voltage control without reference to a processed control sequence. However, this local controller may just be an input/output module which interfaces with the distributed controller where this provides sufficient speed of response.

9.4 Pre-event monitoring

9.4.1 Control capability introduced

This stage would take place ahead of Black Start declaration to improve the capability of the DRZC through greater assurance and better forecasting.

A capability which is introduced through a control scheme is real-time assurance of plan availability and control communications through use of heart-beat updates. This is seen to add significant value due to streamlining existing self-declaration processes for unavailability and the capability to observe individual DER availability which may link to commercial terms.

Pre-event monitoring and recording of demand profiles and generation profiles may be used by the controller to improve its demand forecasting and generation forecasting modules where applicable.

9.4.2 Design variations

Depending on the implementation method, demand and generation forecasting modules may require input from the DMS system, manual input from a control engineer or a forecast provided by the DER locally; and offline modelling may be needed to provide the specific restoration routes to be used after network changes occur.

9.5 Initiation stage

9.5.1 Control capability introduced

In the initiation stage, the first step is to ensure that communications exist with all required energy resources. In addition, the DRZC should declare availability to the control operator. This process should include declaration of availability for all required energy resources. However, it is possible that for staffed DER sites, this availability declaration will be manually triggered after readiness checks are completed.

SCADA data, coupled with local controller data, informs the DRZC of the network state to enable restoration routes to be followed, this replaces the local strategy development from the manual process.

9.5.2 Design variations

The initiation of the control sequence can be triggered either manually or automatically. At this stage, it is desirable for this to remain a manually triggered action to enable alignment of DRZC start with wider national restoration strategy timelines. However, this represents a possible future functionality and is considered as a design option.

In addition, it may be possible to use these schemes to pre-empt a blackout scenario and default to islanded operational mode. However, this has not been progressed by the project due to the potential for islanded operation to exacerbate system issues, particularly if the solution were widely deployed across GSPs with excess generation. The Resilience as a Service (RaaS) project will review this concept and longer-term Black Start control schemes may incorporate these findings.

It is possible for the pre-energisation network configuration processes and protection changes to be executed either by the DMS or by the DRZC dependent upon the solution implemented.

9.6 Anchor DER stabilisation

9.6.1 Control capability introduced

A key functionality from the DRZC is to enable stable operation of the Anchor DER which provides the voltage and frequency reference for the power island. All models allow for incremental block loading of this unit and consider methods for enhancing this block load capability. The designs consider different technologies which can provide a minimum level of stable demand and the specific control strategy for this, considering resources such as BESS and load banks. This process might aim to achieve a steady ramp for the Anchor DER to achieve stable operation without causing stress to the generator. It is appreciated that different Anchor DER will all have different block loading capabilities and the need for fine control of demand will vary. However, where energising a primary substation or other blocks of demand where there are risks of instability due to the size of load, this type of control offers a mitigating option.

9.6.2 Design variations

All designs consider alternative technologies that could provide the stabilisation capability, referencing against a load bank as a baseline due to the intent to test this process during the live trials.

Alternative control strategies exist using either incremental reserve margins or block load pick-up risk calculations to calculate the required flexible demand size.

When considering the percentage load to be applied through this ramp procedure, there is variation between the designs, with some suggesting that headroom is kept on the flexible demand load in order to respond to over frequency events.

9.7 Network growth

The distribution network switching plan is followed during the network growth stage to connect other DERs providing support services and additional network loads. The logic process is carried out on the distributed control system or the central control system or may be executed through the DMS directly after control engineer instigation.

All models suggest use of local controllers at the Anchor DER and other DER sites to regulate voltage and frequency and maintain overall power island stability. Some models suggest use of DER internal control systems with instructions issued via the distributed controller, while others suggest using local control to provide additional DER control settings using the existing DER control functionality (e.g. virtual droop characteristics through altering P/Q setpoints).

After DERs are connected, the DRZC will forecast the expected demand at a primary substation and, where this remains less than the block loading capability of the island, it will energise the load. This may require action to reduce the flexible demand with various control methodologies proposed. Incrementally, this will grow the network to the boundary point of the DRZ, with as much demand energised as the DERs can supply.

Figure 9.2

Possible control response as distribution power island is grown

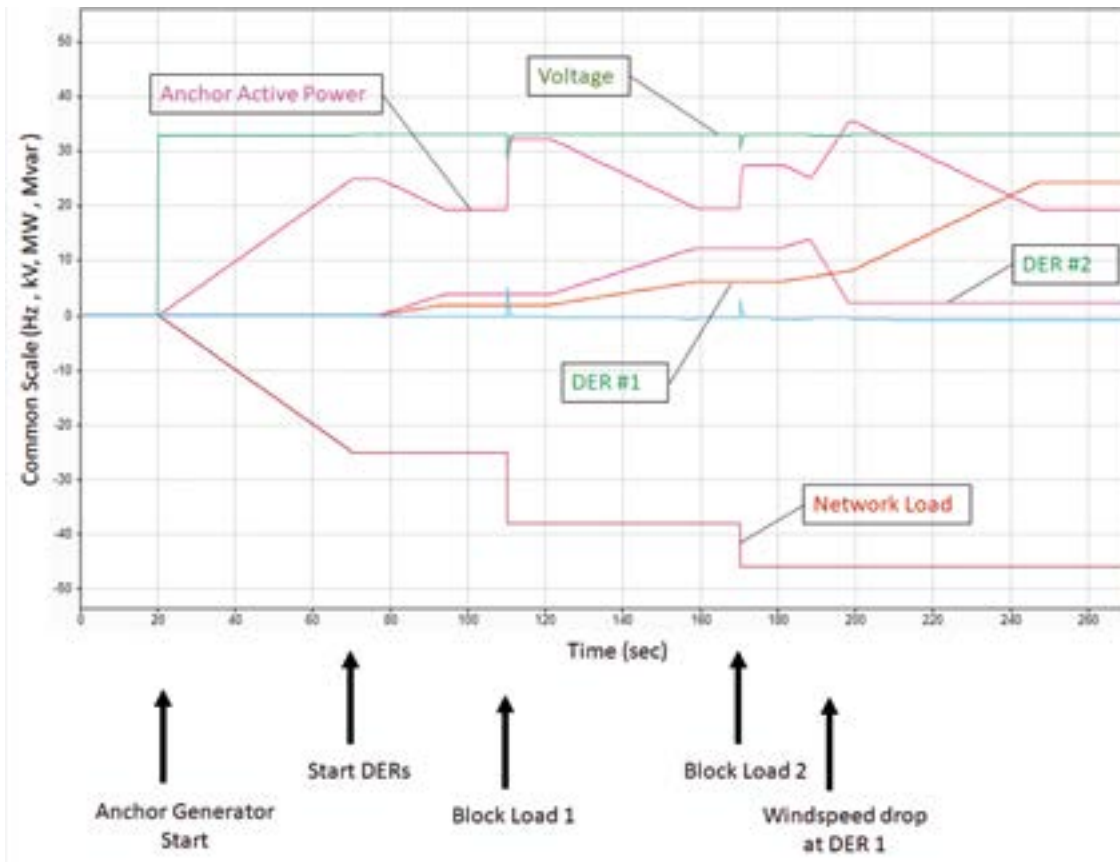

There are multiple strategies for implementing this network growth stage across DRZC designs.

The first key difference is the sequencing of demand reconnection and DER energisation. Under some designs, demand restoration is considered as an earlier stage due to the potential to bring the Anchor DER into its mid-range of operation quickest where it can regulate voltage and frequency more easily. Other solutions suggest the start of support DER services to enhance the overall block load capability of the power island ahead of this process.

The second key difference is block load methodology, consisting of load forecasting strategies and block load pick-up capability estimations.

To calculate a block load pick-up capability for the power island, methods proposed include using the flexible demand to stress test the network DERs to get a real-time figure of block loading capability or use of a summed incremental reserve margin with pre-calculated capabilities for each DER across its operational range.

Within this block loading process there are also alternative approaches for demand forecasting, some use pre-recorded network data to estimate this figure with a cold load pick-up modifier, some rely on control engineer data input and others use pre-calculated worst case ranges to mitigate the risk of under-frequency.

After power island block loading capability has been assessed to be less than the anticipated load, these can then be automatically reconnected or flagged to a control engineer

for judgement where considered to have a high risk. A final option is to keep this process entirely manual, with guidance provided to the control engineer only and execution of the process through the DMS.

9.8 Maintaining power island stability

All methodologies recommend automated power island dispatch of DERs and some recommend continued use of flexible demand to regulate voltage and frequency of the power island through continually issuing setpoint instructions. This action is carried out either by the centralised controller for actions which do not require an immediate response or through local controllers where the requirement is for a very fast response. This could include load shedding where required to respond to faults or sudden change in generation conditions that mean the level of demand restored is not sustainable with the connected DERs.

9.8.1 Design variations

Not all design proposals include demand shedding schemes, some continue to use the flexible demand to regulate against changing generation outlook and others use DER response only. In practice, all are expected to shed demand if needed. This requirement will be a function of what resources are available and the flexibility they provide.

Some designs optimise the level of renewable energy that can contribute, whilst others optimise the overall power island block load pick-up capability through keeping the Anchor DER in its optimal operational range.

9.9 Power island synchronisation

All design proposals allow for the power island being synchronised to the external system as part of the wider restoration process. Under all designs, the instruction to synchronise is issued manually by the control engineer, this is in line with safety requirements and reflects that this may be a coordinated distribution network and transmission network action.

To achieve this, specific synchronisation relays are required to ensure frequency and stage matching between the power islands. This is not a specific DRZC functionality, however all proposals can adjust the output of DERs to achieve stage and frequency matching through either distributed or centralised controller schemes changing setpoints on the local controllers.

9.10 Post transmission network energisation

All control strategies consider the transition from micro-grid operations to macro-grid operations. Where the control scheme operates the Anchor DER in isochronous mode, this functionality would be disabled. Where possible, it is suggested that DERs are changed to droop settings through use of the local controllers only, but the objective of the control scheme will no longer be to maintain voltage and frequency setpoints within the power island directly and objectives may be to maintain float power transfer at the point of connection or to export additional real and reactive power at this boundary point.

9.10.1 Design variations

A key capability which is a design variation under some DRZC proposals is the use of the micro-grid as a virtual power plant. Where a control engineer requests real or reactive capability, a suitable combination of actions from available DERs is calculated and the DER is instructed to a real or reactive setpoint. This action is calculated by the central or distributed controllers and can be issued by the control engineer as either a setpoint figure or a voltage target. Where possible, the remaining active and reactive power incremental reserve margins for the power island should be shared with the control engineer to support wider network restoration through further block loading or network energisation.

9.11 Conclusion

A DRZC has potential to add significant value to the restoration process. DRZC design requirements will be detailed in the second Power Engineering and Trials – Power Systems Studies Part 1 report. Through progression of multiple designs, the project can optimise the overall DRZC requirements through detailed review of the proposals. Findings from the refine stage desktop exercises will feed into the human machine interface design for DRZC and demonstrate points where control engineer intervention is desirable. The project plans to deliver a DRZC ‘black box’ inclusive of hardware in the loop testing in a real-time digital simulation environment.



10.1 Proposed command and control structure

Based on the analysis conducted by OST and stakeholder feedback, Distributed ReStart now proposes a model that enables:

- NGESO to coordinate nationally; and
- the respective licence area DNO to lead locally.

This cooperative method is built from the DNO led procedure outlined, reducing the organisational impact and enhancing restoration timelines.

10.1.1 Black Start leadership

The Power Systems Manager for NGESO is the lead controller of the restoration process, responsible for declaration of a Black Start and for declaration of the transition between Black Start stages, including its cessation. No change is required in this capacity from the existing capabilities under OC9 and all instructions issued by the Power Systems Manager or by anyone delegated this authority should be treated as an emergency instruction, only to be refused on the grounds of safety.

It is proposed that a separate Silver Command team headed by the NGESO duty officer would act as the liaison between this command and control position and wider industry directives [8] inclusive of but not limited to BEIS, CORESO and OFGEM. Strategic guidance and status reporting will be provided through this function and no change is recommended from its current format.

In the case of Scotland, under exceptional circumstances considered in OC9, they should assume the responsibility for regional leadership including instructing the start of a DRZ. This is analogous to the existing process and no change is required.

10.1.2 DRZ leadership

NGESO will instruct the start of a DRZ to the respective licence area DNO. The DNO control room manager will then have delegated responsibility to manage the restoration independently until the DRZ boundary point(s) are energised. Where a DRZ requires no external connection to the transmission network to sustain supply for an extended period, this delegated responsibility and instruction to start could be explicit in the contract without need for instruction.

Through contractual or codified means, as explored in 'A high level outline of commercial and regulatory arrangements' (a report by the Procurement and Compliance workstream), all instructions issued to DER providing a Black Start service by the DNO control room manager or by anyone delegated this command and control authority should be treated as an emergency instruction, only to be refused on the grounds of safety.

As a DRZ will only include up to 132kV assets, in England and Wales this always remains the responsibility of the respective DNO. For Scotland, this means it may include transmission level voltages, for this reason post 132kV energisation the TO function would assume control of the restoration process. This would reflect a similar level of control to that given under STCP6.1 for the Scottish TO to act with delegated authority from NGESO to manage a restoration process.

10.1.3 Roles and responsibilities

Taking the approach that overall Black Start leadership and national control is the responsibility of NGESO and overall responsibility for the DRZ belongs to the DNO, the following division of responsibilities is proposed. This will enable efficient execution of the plan without need for reference to the national controller except where this is useful for incorporating DRZs into national strategy or coordinating them alongside the start of other resources.

Table 10.1

Table showing the operational responsibilities across organisations for the proposed organisational model

Action	Responsible under current Black Start	Responsible in central control model
Declare Black Start	NGESO	NGESO
Responsible for national strategy	NGESO	NGESO
Responsible for regional strategy	NGESO/Scottish TO	NGESO
Instruct start of plan	NGESO/Scottish TO	NGESO/Scottish TO, only withheld where a DRZ requires access to the transmission system to sustain supplies for an extended period
Instruct start of Anchor DER	N/A	DNO
Instruct transmission switching actions	NGESO	NGESO
Physical transmission network actions	TO	TO
Physical distribution network actions	DNO	DNO
Physical actions of contracted generation	Black Start provider (or virtual lead party)	Multiple individual providers
Instruct DRZ energisation route	N/A	DNO/Scottish TO ¹
Instruct growth option outside of DRZ boundary	N/A	NGESO
Instruct DERs within a DRZ	N/A	DNO/Scottish TO
Instruct DERs outside of DRZ boundary	NGESO where Black Start provider	NGESO
Instruct non-contracted DERs (emergency instruction equivalent procedure)	NGESO through DNO (clarified through GC0143)	NGESO via DNO instruction
Manage overall distribution power island voltage and frequency	N/A	DNO are frequency lead until synchronisation with an energy resource or demand outside of the DRZ

A plan that relies on local leadership but with appropriate data and strategic communication with the party accountable for national restoration achieves the greatest organisational efficiencies through minimisation of interfaces and reduction in the overall resource requirements. Where a plan can be executed without requiring the overall strategy to be defined this has potential to make use of time before and between the onerous block loading processes for DNOs, making most effective use of existing resources.

After the 132kV DRZ boundary point(s) are energised, the DRZ requires national leadership to integrate the power island into the transmission level procedure but intervention ahead of this point does not add value except to instruct plans that cannot independently sustain themselves for an extended period due to fuel supplies or reliance on co-location with non-dispatchable resources.

10.2 Organisational analysis

The organisational structure and numbers of people required to deliver a distribution led restoration process varies with:

- (A)** the degree of automation utilised
- (B)** the complexity of each individual plan
- (C)** the number of plans to be executed.

Following the method outlined in the process mapping (section 9) and through the application of resource and duration assumptions developed through industry consultation and DRZC report outputs, the overall duration and average headcount requirements has been estimated. During the project refine stage these estimates will be tested across desktop exercise activities. At this stage, they should be taken as indicative requirements due to the continuing development of DRZC specifications and minimum technical requirements.

The following analysis demonstrates how timelines and headcount requirements are impacted by (A), (B) and (C). It does not imply a specific headcount requirement or an exact timeline for restoration and should only be used for comparative purposes at this stage.

¹ A DRZ may span sections of 132kV network inclusive of 132kV energy resources, in Scotland this is a transmission voltage meaning that the TO function would assume overall plan responsibility from the DNO post 132kV energisation.

10.2.1 The impact of automation

It is clear that the extent to which the process is automated will impact upon the numbers of people required to execute a restoration procedure and the timeline that will be possible. Consultation has highlighted that there is a range of automation appetites across DNOs and, given the principle of familiarity, it is important appropriate control engineer oversight is applied to give confidence in procedures. It is likely that the degree of automation will increase over time as technologies are further proven and appetite for automation increases but a single approach is not proposed at this stage.

Following through the sequential procedure outlined in section 9, approximate time and headcount requirements are applied across NGENSO and DNO entities at every process step to extrapolate the possible organisational implications of entirely manual procedures, minimum viable DRZC implementations and solutions which use a very high degree of automation of DMS systems and integrate the DRZC into these procedures.

To model this, the following scenario is applied:

- Manual procedures require direct oversight of two distribution control engineers, one to perform energy management procedures and one to perform distribution network management procedures.
- Automated procedures require supervision by a single distribution control engineer but they are able to conduct other activities in parallel, meaning concurrent monitoring of up to three distribution level procedures could be managed.
- All NGENSO activities require one transmission control engineer for transmission network actions and one energy control engineer for generation instructions and frequency management.
- An automated switching action will be executed twice as fast as a manual switching action due to a reduction in decision time.
- The restoration plan followed consists of three DERs and three primaries to be energised and the point of connection for the DRZC is the 33kV/132kV interface. This is modelled against the Chapelcross procedure used to illustrate process steps.
- Actions outside of the DRZC boundary follow the manual procedure under the DRZC minimum viable implementation, while they follow the automation assumptions where considering the fully integrated model.

Table 10.2

Comparison of organisational requirements to deliver a restoration procedure with use of various levels of automation

Impact	Without DRZC	With DRZC	With DRZC and full DMS automation and integration
Plan duration	23.4hrs	14hrs	13hrs
DNO hours of labour resource per plan	40hrs	13hrs	8hrs
NGESO hours of labour resource per plan	4hrs	4hrs	4hrs
Average DNO headcount requirement	1.7	0.9	0.7
Average NGENSO headcount requirement	0.17	0.17	0.17

Distribution Network Operator impact

This analysis illustrates that a DRZC significantly reduces the headcount and overall resource requirement compared with manual procedures when a DNO is only executing one process. However, there is still a significant headcount requirement when considering execution in parallel with existing Black Start. This is because the stages not automated by the DRZC remain significant in duration, and requirements across the 132kV growth stages and the initial strategy development are labour intensive.

The project has found that there are diminishing returns from overlaying further automation to the DMS, whilst this reduces headcount requirements further and reduces the time for overall plan delivery, most benefit is gained from the automatic management of DERs rather than reduction in network switching time. It is clear that this adds further value due to the further reduced headcount and plan execution time but it can be considered as an optionality for DNOs rather than a requirement to facilitate restoration with reasonable resource requirements.

Electricity System Operator impact

The very low additional resources for NGENSO under both automation levels means that this may be possible to achieve without increasing headcount. However, the scope of DRZC design and DMS automation does not change the organisational requirement for NGENSO.

Conclusion

The diminishing returns from further automation can be attributed to the expected duration for transmission network actions and initial strategic actions. As these share commonalities across multiple plans, there is further benefit to automation not demonstrated through an individual DRZ in isolation. Where desirable, a DNO could further streamline their actions through DMS automation of wider network growth but transmission network actions and integration into national strategy could cause a process bottleneck. Given the significant reduction in control engineer requirements, and overall restoration time improvements, it is recommended that a DRZC forms part of the base organisational design with a manual procedure acting as a redundant option.

10.2.2 The impact of complexity

It is possible that a DRZ may be supplied through many geographically dispersed DERs, this increases the complexity of a procedure through a requirement to manage many energy resources but benefits the collective zonal capability to contribute significantly to national restoration through its increased size.

To investigate this variable, the numbers of DERs to be coordinated is varied from 1-6 and outlier values of 10 and 20 DERs per zone are used to investigate how this model might apply should the Distributed ReStart model be rolled out across smaller energy resources in the long-term future.

Figure 10.1

The relationship between work effort requirement and the number of DERs included in an individual DRZ where enacted using a manual procedure

Manual procedure sensitivity to numbers of DERs

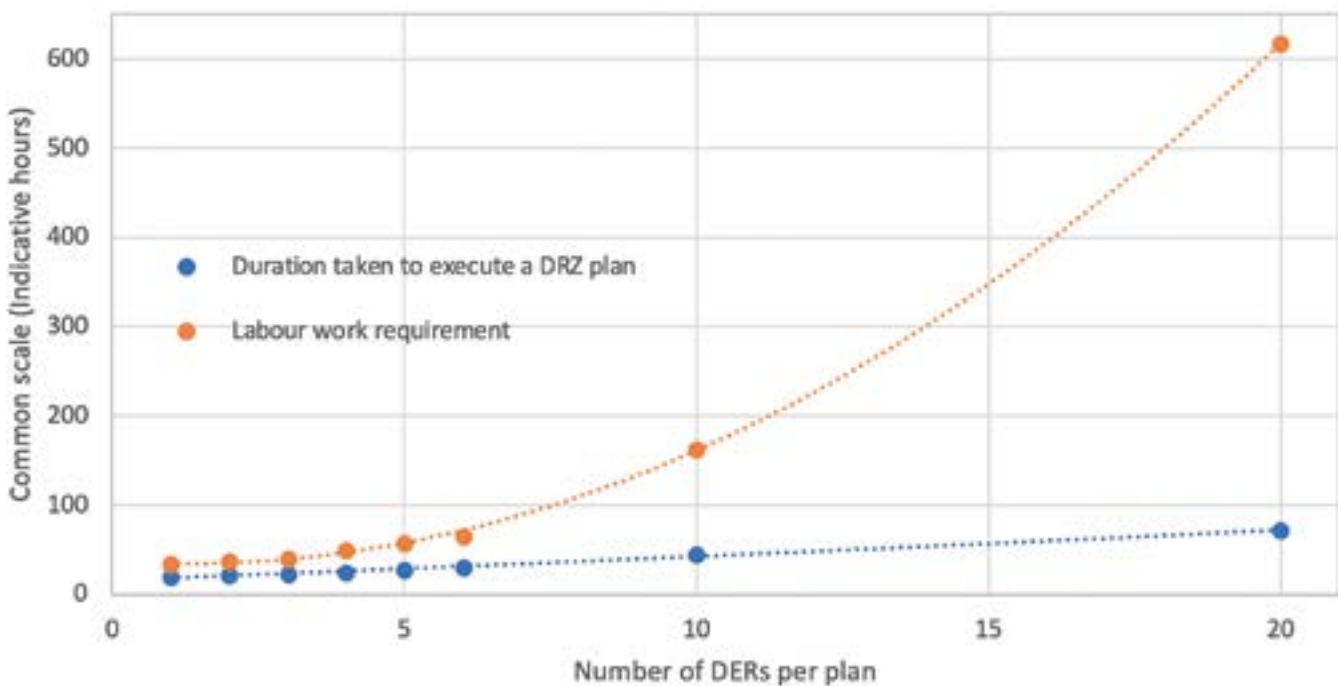

When considering the manual procedures, there are additional resources to be coordinated concurrently. This leads to a corresponding increase in plan execution time due to the limitations on an individual's capability to closely monitor and dispatch many DERs. The increase in labour requirements may cause a barrier to entry for smaller scale DERs and

could require the functional requirements to be met using larger scale generation units only. This limits the value and future scalability of a DER led restoration process. DRZC automation is therefore considered essential for long-term solutions to access ever smaller participants.

Figure 10.2

The relationship between the number of DERs and the labour requirement to execute a plan when using a DRZ

Procedure with DRZC sensitivity to numbers of DERs

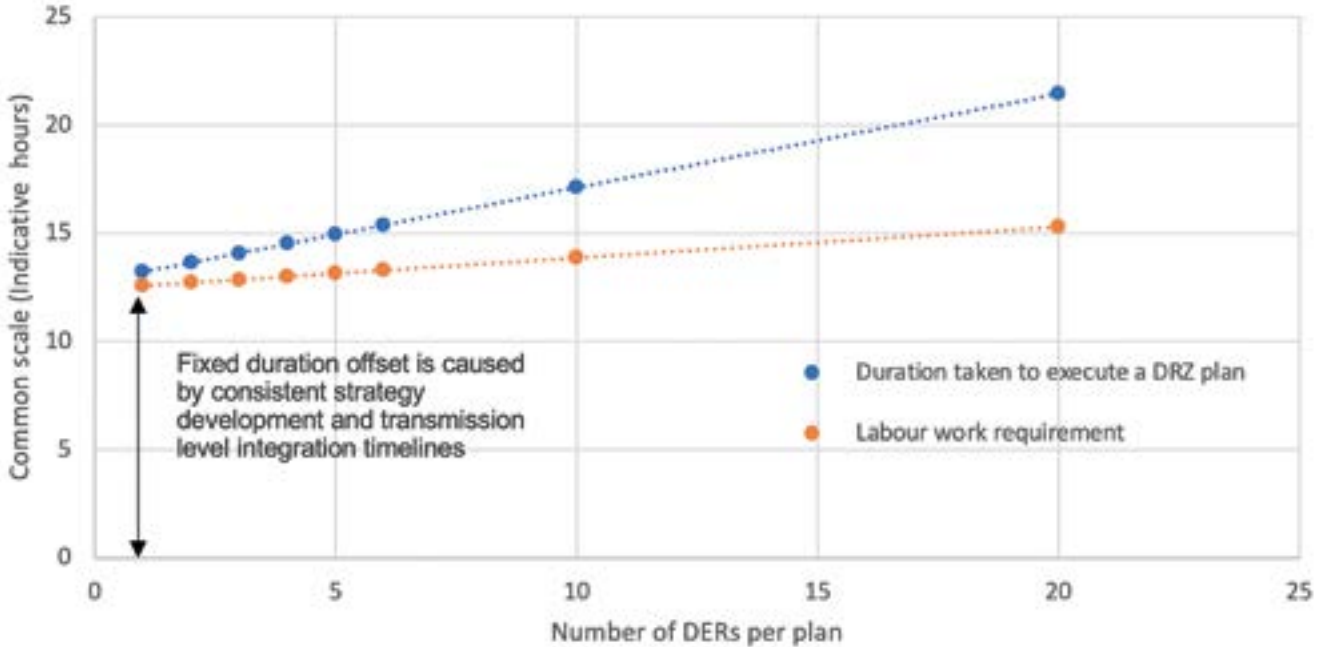

The major benefit brought by a DRZC is allowing participation of smaller energy suppliers through enabling more resources to contribute to a single plan. The duration and the workforce requirements are still increased due to the sequential process. However, the levels are not anticipated to require a large degree of organisational change under likely implementation models and provide capability to manage longer-term solutions which may incorporate many DERs.

A plan which only delivers a distribution level restoration process represents a decrease in complexity. Due to DRZC functionality very little control engineer input is required to maintain stability after the plan is concluded. This is illustrated in table 10.3, which demonstrates that local supplies could be restored very quickly if DER with short start-up periods were used. This creates an opportunity to improve restoration timelines without delivering the full energisation process, enabling a greater number of plans to be delivered within a 24 hour period. This improves performance against the expected Black Start Standard metrics.

Table 10.3

Table showing an indicative comparison of the time taken to execute project goals

Impact	Transmission network restoration	DRZ restoration only
Plan duration	14hrs	5hrs
DNO hours of labour resource per plan	13hrs	6hrs
NGESO hours of labour resource per plan	4hrs	1hr
Average DNO headcount requirement	0.9	1.1
Average NGESO headcount requirement	0.17	0.75

10.2.3 The impact of multiple parallel DRZ in a DNO licence area

A possibility for improving restoration timelines is to use multiple DRZ executed in parallel in a single DNO area. With this increased restoration speed, additional headcount demands are anticipated, and existing organisational structures would experience greater change. However, staggering of DRZ implementation offers opportunity to realise operational efficiencies through greater utilisation of resources. Therefore, concurrent enactment of up to five DRZs within a single restoration zone is analysed to show the implications of assigning responsibility for more than one DRZ to a single DNO.

When considering manual procedures, there is minimal operational efficiency through enacting multiple plans

in parallel and a linear relationship is established where more plans directly require greater labour hours. Therefore, higher headcounts would be needed or restoration times would slow.

This contrasts with a plan that has a DRZC implemented because, whilst the numbers of switching actions increase for a DNO, energy resources do not require micro-management and more than one plan can be monitored by a single control engineer. However, when a threshold is met for concurrent supervision of plans, a step change is observed in the labour requirement. This means the number of plans started in parallel should be reduced below this threshold figure. Consultation has shown that this figure could be up to three processes in parallel but this figure will be tested through desktop exercises and eventual roll-out.

Figure 10.3

The relationship between the number of DRZ procedures enacted in parallel and the labour requirement when enacted using a manual procedure

Manual procedure sensitivity to number of DRZ enacted in parallel

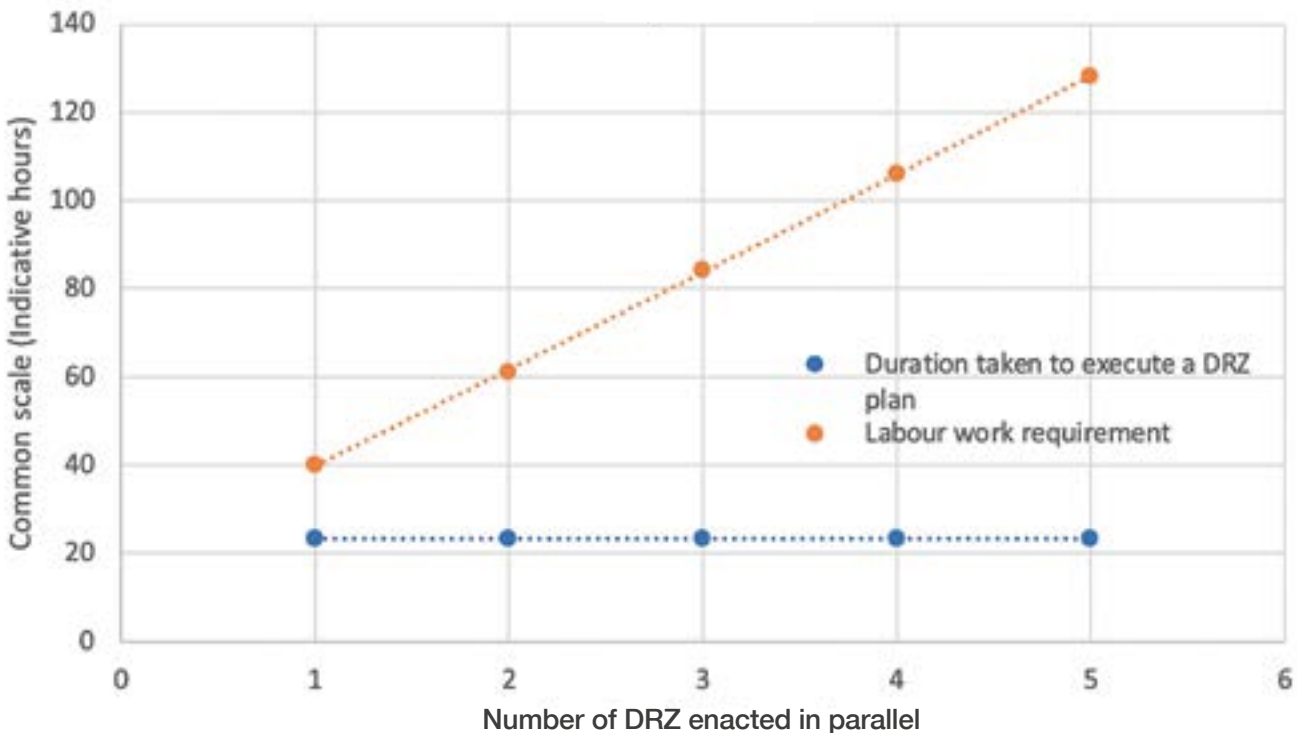
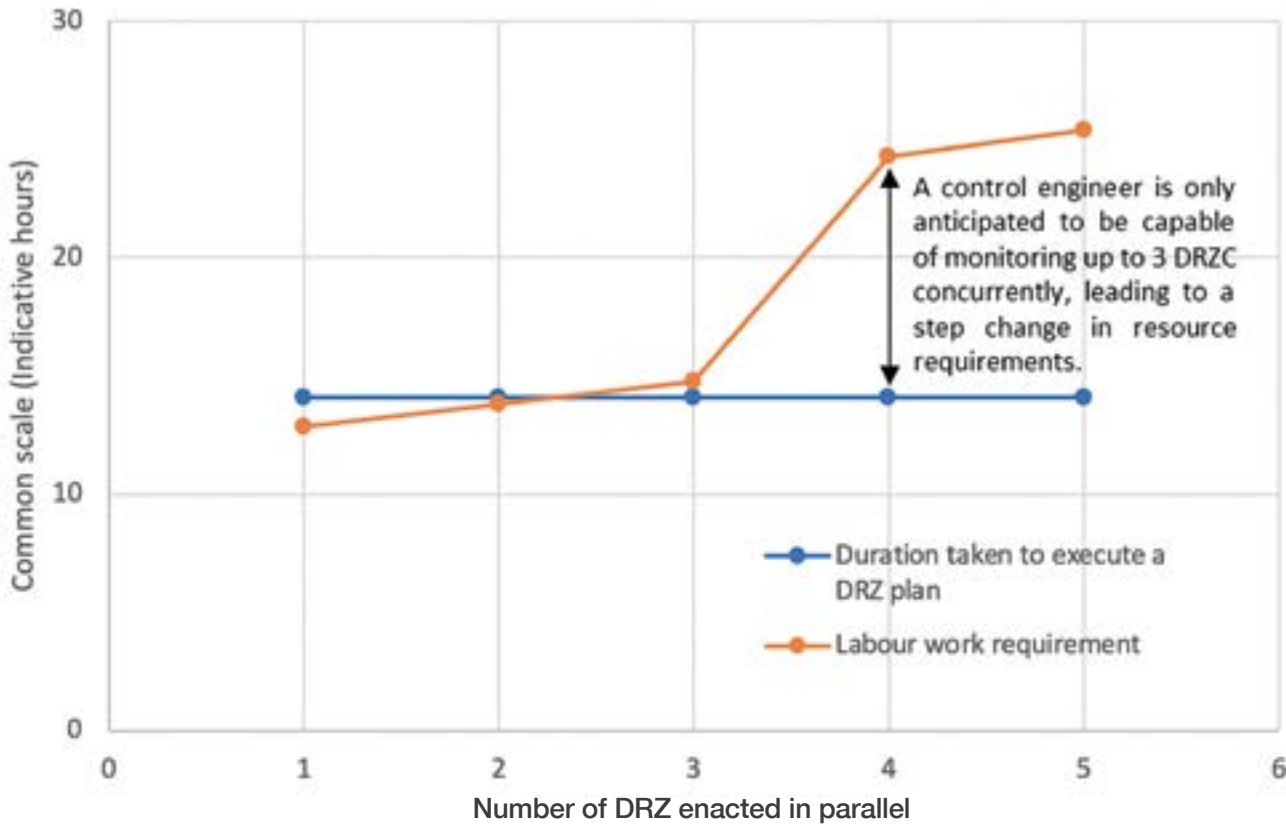

Figure 10.4

The relationship between labour requirement and the number of DRZ enacted in parallel when enacted with use of a DRZC

DRZC procedure sensitivity to number of DRZ enacted in parallel



10.3 Organisational structure

There will always be a balance between reducing the restoration timeline and managing the overall organisational headcount. Even highly automated processes cause an increase in the labour effort requirement due to supervision and approval of high-risk actions.

The organisation most affected by delivery of Distributed ReStart procedures is the respective licence area DNO which has a moderate requirement for labour hours under all procedures. Whereas the low level of NGENSO intervention needed ahead of transmission level restoration means a DRZ is likely to require less labour time than an existing Black Start LJRP.

10.3.1 Electricity System Operator

Personnel

There is no specific requirement for organisational change within NGENSO unless the collective number of LJRP and DRZ plans managed in parallel significantly increases from the current day. In the short term, this means that DRZs which are instructed as an alternative to an existing

LJRP require no additional headcount under the proposed organisational structure. However, as smaller scale resources are accessed through the DRZ methodology and more plans are needed to replace a single LJRP, there may be a requirement for additional energy and transmission control engineer(s). It is not expected that this will be a requirement for business as usual processes, meaning that it could be resourced through called-in personnel or through greater efficiency of existing procedures through use of advisory tools.

This requirement also only exists when considering a national restoration, the more likely regional restoration case could be managed through existing personnel only given the minimal headcount requirements per plan.

Capabilities

The skillsets required are also consistent with the present strategic role played in the power system. Whilst greater visibility of the distribution network actions should be facilitated, no change to the overall skillsets are needed due to existing 132kV control capabilities. The existing training level should be maintained but also include the scenario of using a DRZ to energise and synchronise to the transmission network.

10.3.2 Distribution Network Operator

Personnel

The DNO labour hours requirement is extremely sensitive to the roll-out of a Distributed ReStart Zone controller. The process for an individual DRZ may be possible to manually execute under minimum staff conditions. However, this requires full time commitment of existing headcount to the process for the full plan duration. This would mean it could only be enacted as an alternative to an existing LJRP which may not be suitable for the goal of achieving faster restoration timelines, except for a DNO which does not have an existing LJRP.

It is recommended that to enable a DNO to manage a plan in parallel with an existing LJRP that a Distributed ReStart Zone controller is implemented. Under this condition it is likely that a single DRZ procedure could be executed in addition to the LJRP through staggering actions around labour intensive LJRP stages such as block loading and network segregation. Alternately, existing headcount could be used to enact multiple DRZ concurrently, but this would detract from the conventional Black Start procedure or require additional headcount.

As the number of DRZs to be started increases or the complexity of an individual plan is increased beyond the baseline case studies, this creates a need for additional control engineer labour time under all scenarios. Unlike the NGENSO potential resource constraint, the enhanced operational role of a DNO means that this also exists under a partial/regional restoration.

An option would be to use called-in or self-starting workforce analogous to the existing procedure but given the integral role played across all stages this would lead to a delay in the restoration timeline. If a reliance is built on non-dedicated personnel, this could also be extended to providers. This has potential to reduce the costs from both the operators and the providers but introduces operational risk. Where a DRZ is used as a supplementary resource to a conventional LJRP and would be staggered, this is an acceptable arrangement; where it provides the core service, 24 hour capability should be a preferred option.

Capabilities

A manual procedure requires entirely new energy and frequency management capabilities to be developed within a DNO, creating a new energy management control position under Black Start that would be directly responsible for managing these assets. Whilst wider energy control capability is developing through the DSO model it is mostly being developed through active network management schemes which take automatic actions to curtail output to manage constraints. The DRZC mirrors this wider development and reduces the new capability requirements. However, as high-risk decisions are still expected to be referred to DNO control engineers directly, specific and consistent Black Start training will be required. The desktop exercises in the refine stage will provide a model for this training requirement.

10.3.3 Distributed Energy Resources

Personnel

The capability to self-start and follow specific despatch setpoints and ramp procedures is outside of the operational capability built for most DERs. Therefore, appropriate personnel to fulfil this capability are needed. Manual processes require people at site for communications to be issued verbally alongside data exchange, whereas the DRZC will issue instructions via data only, enabling remotely controlled sites to interface directly without need for human intervention.

Most a-synchronous resources are remotely controlled. Depending on the technology, direct on-site human intervention may be needed after loss of supply. This is typically provided through a fleet maintenance approach rather than direct allocation to a unit. For normal operations, time between failures means this can guarantee a very high availability rate but an alternative solution would be needed for Black Start. Given that many failures would be expected, and communications would not facilitate call-out of non-allocated support staff, it is expected that organisational change would be needed. Options include: change of control schemes to allow automatic start-up; a contractual method guaranteeing priority and self-starting policies; or fully dedicated on-site personnel.

For most synchronous resources, self-starting and block loading procedures will require a staffed site, but this will often not be different from normal operational procedures. The options available are the same as those outlined for a-synchronous resources but it is more likely that fully dedicated 24 hour staffing will be desirable and possible. Overall, the structure that a provider adopts remains its responsibility. Mandated 24 hour capability to deliver a Black Start procedure may not be a minimum requirement in all cases, as staggering of plan start times can reduce the overall organisational burden and therefore limited flexibility could be built into the functional requirements. It is anticipated that this would form part of the time to energisation technical criteria. Flexible arrangements are expected to be accepted, with a contractual requirement for appropriate training, and directly allocated to the asset should a Black Start occur. This applies for all staff that are required in enacting the internal self-start procedure and any other requirements identified to enable delivery of its contracted service.

Capabilities

Given that DERs do not have existing independent self-start capability, where this requires human intervention to deliver, bespoke training plans for the site would be a minimum requirement.

10.4 Next steps

10.4.1 Desktop exercises

The development of process maps has been iterative, taking account of stakeholder comments, expectations or efficiency goals. The next stage of this project is to test these procedures through use of desktop exercises and potential event simulations. This, coupled with the learnings from live power engineering trials, will provide confidence in the efficacy of Distributed ReStart should a Black Start event occur and provide the model for training and assurance of the ongoing service.

Desktop exercises will be staged with an intent to test the communications and data exchange models to ensure the appropriate level of situational awareness is given to all staff. This will inform the human machine interface requirements for systems and verify the data transfer requirements across organisations.

Significant value is expected to be unlocked from exercises with cross-industry participation. These exercises may be repeated multiple times and will look to test the various scenarios that may lead to a Black Start procedure being enacted to ensure fit for purpose processes that can adapt to different possible needs cases.

After process verification and result gathering, any change requirements for systems may be fed into the final DRZC design requirements, or into recommendations on the required data points to be mapped between EMS, DMS and DRZC systems. This may allow for further exercises using simulation of the DMS or final DRZC designs which would enable further refinement of requirements for GB roll-out and test real timings to execute automated processes.

10.4.2 DRZC stage 2

The DRZC design is progressing from the initial design and requirements into the development and test stage. Micro-grid and power systems control experts will be engaged to produce and conduct hardware in the loop testing of a control system based on a real-time digital simulation model of the Chapelcross case study. This will enable the hardware and software to be finalised and for appropriate capability to be demonstrated under a wide range of scenarios.

This will replicate a possible assurance process for DRZC designs, simulate and test control responses to a wide range of conditions and provide a final cost for implementation and roll-out by the manufacturer.

It will be important to use findings from initial desktop exercises on information visibility requirements to design the human machine interface and the specific activities where control engineer decision making continues to add value.

10.4.3 Refine processes and organisational structures

We are conscious of the importance of maximising the efficiency of the processes and organisational structures. Due to the initial requirement for processes and organisations to deliver a technical procedure, consultation has focused on engineering input but the project appreciates that a broader range of views may unlock further insights and more cost and time effective restoration plans.

For this reason, the project will engage organisational design experts to conduct a thorough review from a business perspective. The existing Black Start process has had a similar review, enabling resource levelling to allocate roles within NGENSO. A similar procedure will be applied to the OST design proposals, which will contribute to final task allocations.

10.5 Conclusions

From the process and organisational analysis considered in this report, we recommend the use of a DRZC. However, we believe that this control functionality does not need to extend beyond the distribution level power island, nor is there significant value in automating every stage through Distributed ReStart Zone controllers. A balanced, minimum viable controller option should be used in the initial roll-out of Distributed ReStart offering a solution similar to active network management with regards to DER control. This will require distribution control engineer intervention but allow a single control engineer to manage a distribution level plan without inhibiting the existing Black Start process.

It is recommended that where it is not possible to introduce a DRZC, a maximum of one DRZ plan is instructed per DNO control room to prevent excessive distribution control engineer requirements. This method would still enable multiple plans to be enacted in parallel due to the distribution of this responsibility across multiple organisations.

Where a DRZC is implemented, we expect that more than one DRZ plan could be executed within a 24 hour period and existing resources may be able to manage multiple restoration plans in parallel. This could result in the number of DRZ plans per DNO control room being increased. However, simulated DRZC training exercises are needed to determine the relevant threshold for simultaneous management. The baseline capability of three DRZ plans in parallel is based on industry consultation but, due to the uncertain design of a controller, this is an indicative figure only and we do not propose that justifies organisational change.

Distributed ReStart



Operational telecommunications

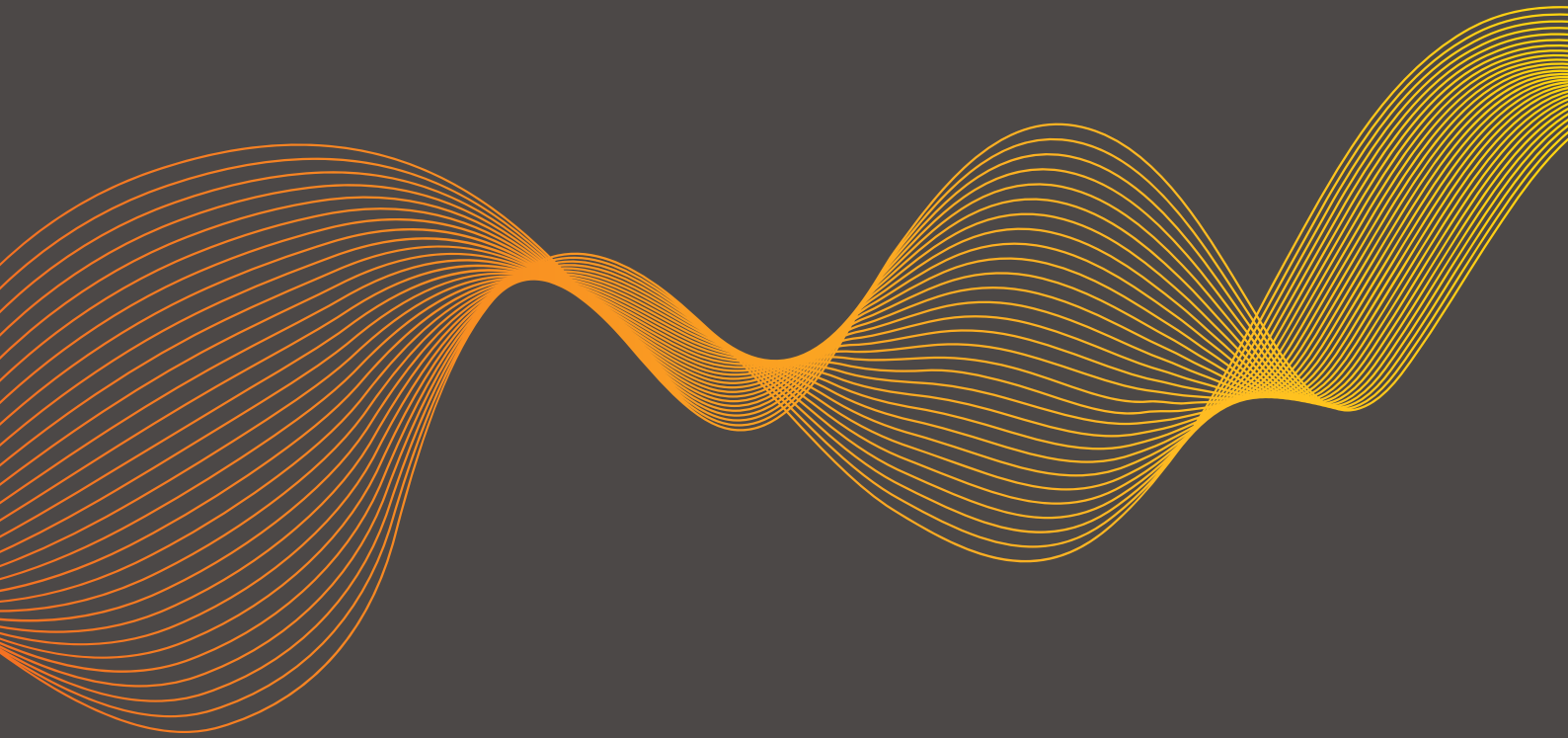



Operational telecommunications play a vital role in the safe, reliable and efficient operation of the transmission and distribution networks.

11.1 Introduction

The infrastructure to deliver voice and data plays a vital role in the successful delivery of any Black Start process. This comprises of teleprotection, the systems to monitor and control the power grid and operational telecommunications.

At present, the relatively small number of Black Start participants utilise dedicated fibre links for operational telecommunications (voice and data). Introducing DER into a Black Start process could lead to a considerable increase in the volume of stakeholders, data points and the number and types of potential operational telecommunications (e.g. microwave, satellite).

The 'Operational, System and Telecommunications Viability Report' contained a review of the current telecommunication infrastructure alongside a high level evaluation of the various options available to deliver the telecommunications capability required to support Distributed ReStart (either immediately, or within the project delivery time frame). It also included a discussion of the systems potentially required for managing Distributed ReStart; the impact and role of cyber security on operational telecommunications; and the telecommunications infrastructure used at two case studies (trial sites from SP Distribution (SPD) and SP Manweb (SPM) networks).

This report includes the available outputs from the project design stage, together with the methodologies used for the ongoing work. The results of that work will be shared in a second design stage report to be delivered towards the end of 2020. This will contain a draft functional specification for operational telecommunications and associated cost ranges from our development of cost case studies. Working with a number of DNOs, these cost case studies cover a range of technologies and terrain.

In this report, we detail:

- the approach taken to the design stage;
- a high level summary of the viability report outputs;
- the methodologies used to develop the functional specification and cost assessments;
- the cyber-resilience assessment completed to date, presented in section 15; and
- the next steps for Distributed ReStart operational telecommunications.

11.2 Approach to design stage

Our design stage approach to operational telecommunications has been to focus on what resilience is appropriate, technically achievable and economically viable; and how we gain assurance that the required resilience is provided at all times.

Rather than dictate a technology, we are seeking a solution that is technology agnostic and applicable across GB. The development of a set of functional requirements has been central to our work. Alongside this, we have been working with stakeholders to assess the potential costs of meeting a Distributed ReStart functional specification using different technologies and for different case studies (considering different terrain, existing technologies, augmentation of existing solutions and multiple party service provision).

11.3 Functional requirements

A first set of OT requirements, those for model D (DNO manual control), were developed by Distributed ReStart and consulted upon. Feedback has been compiled from DNOs, DERs and specifically discussed with the ENA Open Networks Strategic Telecommunications Group (STG).

Development of the functional requirements and consultation continues with operational telecommunications suppliers and the existing consultees. As we are seeking to complement and avoid conflict with other initiatives, the draft functional specification will not be complete for this design stage report I. It will form a central part of design stage report II later in 2020. Key information to be reviewed in the development of the functional specification includes:

- the DRZ controller outputs (due September 2020)
- outputs from the STG work on Operational Telecommunications Standard for Connected Distributed Generation and Storage (currently in an early stage of drafting)
- the DER Cyber Security Connection Guidance (due to be published September 2020, consulted on in 2021).

11.4 Cost analysis

The relative costs of implementing the functional specification against a range of technologies (as identified in the OST viability report) are presented in section 15. These costs are indicative only and will vary considerably with specific sites and conditions.

Cost case studies for a range of options are being developed, based on the DNO and or NGENSO providing Distributed ReStart operational telecommunications as per the functional specifications for the operational models considered by the project.

11.5 Cyber-resilience

The end-to-end cyber-resilience of operational telecommunications expected to be used in Distributed ReStart has been assessed, alongside mitigation of both the technology used and the overall solution. This is presented in section 15.

11.6 Operational telecommunications content in design stage reports I and II

The operational telecommunications aspects are split across two reports, alongside the systems and DER control interface analysis. An outline of the split is provided in section 19.

12. Summary of existing operational telecommunications and viability report



The existing operational telecommunications network inherently influences the type of technology and design required for Distributed ReStart.

12.1 Introduction

In the viability report, we presented an assessment of the current operational telecommunications, including voice and data communication infrastructure, the technologies currently in place and the systems used by NGESO, NGET, SPEN and the DNOs.

During a traditional Black Start, NGESO leads the process, collaborating with TOs, DNOs and Black Start power station

providers to restore the electricity grid after the extremely unlikely event of a total or partial shutdown. The enactment of a traditional Black Start by NGESO currently requires an open voice communication channel (i.e. dedicated and available trunk routes) between the applicable parties (TOs, DNOs and Black Start power station providers) and in some cases visualisation of network or switching actions via SCADA/telemetry using the Integrated Energy Management Systems (IEMS). The communication maps during the LJRP phase are depicted in the diagrams below.

Figure 12.1
Current Black Start communications map outside of block loading

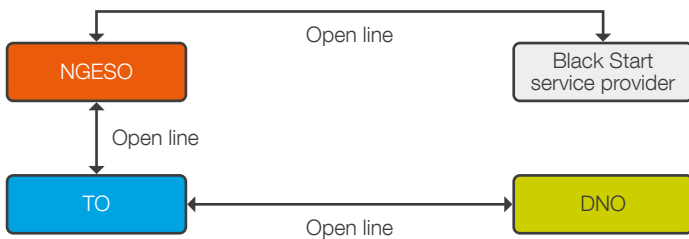
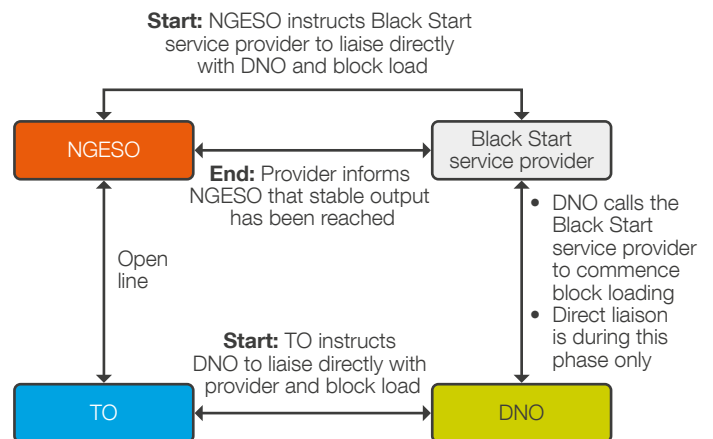

Figure 12.2
Black Start communications map during block loading



Of particular note is the National Grid operational telecommunications (OpTel) network as it is the designated network for traditional Black Start communication.

OpTel: The OpTel network is a synchronous digital hierarchy (SDH) network owned by National Grid Electricity Transmission (NGET) and subscribed to by NGESO. It consists of a set of optical fibre and transmission equipment connecting National Grid's operational sites and leased circuits to third-party locations.

The third-party locations include transmission connected power stations, some embedded generators, DNO control centres and other strategic sites. The OpTel network enables voice and data communication between the National Grid control centres and various sites. It carries control telephony, SCADA, protection and various other data traffic to support the operations of the transmission grid in England and Wales. The OpTel network is currently Black Start power resilient as the communication path to support the Black Start process is supported by a combination of batteries and diesel back-up supplies.

As described below, equivalent networks are utilised by SPEN and SSEN for Black Start restoration in Scotland.

12.1.1 SPEN operational network

The SPEN operational network consists of privately-owned infrastructure and leased services and provides diverse telecommunication services between the centralised SPEN control centres, grid supply points and supergrid sites. This operational network provides control telephony, SCADA, protection and other operational data services for the SPT, SPD and SPM licence areas. In addition to control telephony, SPEN currently utilise Airwave mobile radio for Black Start operational field personnel. All elements of SPEN's infrastructure that support Black Start services are Black Start resilient utilising a combination of batteries and diesel generators.

12.1.2 SSEN operational network

The SSEN Operational Network comprises of privately-owned infrastructure and shared services infrastructure. This infrastructure provides diverse connections to the grid supply points and supergrid sites. SSE operates a fixed private telephony network across its licence area, Black Start third-party connections are routed across this network to the point of handover at their sites. In addition to the telephony network, SSEN also operates a private mobile radio network (PMR) to provide robust voice capability and enhanced reach should a Black Start event arise. All elements of its infrastructure supporting its Black Start capability are built to meet 72 hours + power autonomy utilising a combination of batteries and diesel generators.

The introduction of Distributed ReStart will result in significantly more participants, connection points and interfaces between different organisations, increasing the challenge in providing a telecommunication network to meet the same standards on confidentiality, integrity and availability.

12.2 High level analysis of telecommunications options

The telecommunications options advantages and disadvantages are summarised in table 12.1 of the viability report [8]. We continue to refine our analysis of available technologies and an update of the table will be included in design stage report II.

The technologies deployed to current Black Start generators are mostly fibre core networks and extending the fibre to distributed generators would seem to be the natural route. However, there are many factors involved in deciding on the most appropriate technology. These include whether the distance between end points or wayleave or the terrain makes it less practicable and more expensive to extend the network using fibre optics cable.

13. Operational telecommunications requirements



Any telecommunications infrastructure would need to support the end-to-end voice and data communications necessary to support Distributed ReStart.

13.1 Introduction

Due to existing legacy infrastructure, terrain, familiarity, cost, maintenance and business models, the DNOs and potential Black Start participants use a range of technology to deliver voice and data communication. We are therefore keen to ensure that the solution is technology agnostic.

Although the ability of the implemented technologies to meet the functional requirement is the principal factor determining the technology deployed, other key factors include:

- capital and operational cost
- familiarity
- existing technology and compatibility
- terrain
- maintenance and support arrangement
- reliability
- availability
- regulation and policies.

In this section we describe the process used to develop a functional specification for Distributed ReStart and the conditions for technologies to remain viable. As stated earlier, it is not the intention of Distributed ReStart to dictate a technology (or set of technologies). A functional specification is being developed that will allow Black Start participants to select the most appropriate technology for their needs from the technologies that meet the requirements.

The functional requirements are being considered for each organisational model.

13.2 Organisational models

The four organisational models developed and cited in the viability report are considered in section 7. The favoured organisational model, if adopted, may influence the telecommunication solution and technology deployed to support Distributed ReStart. This solution will then influence the functional specifications.

Figure 13.1
Organisational models

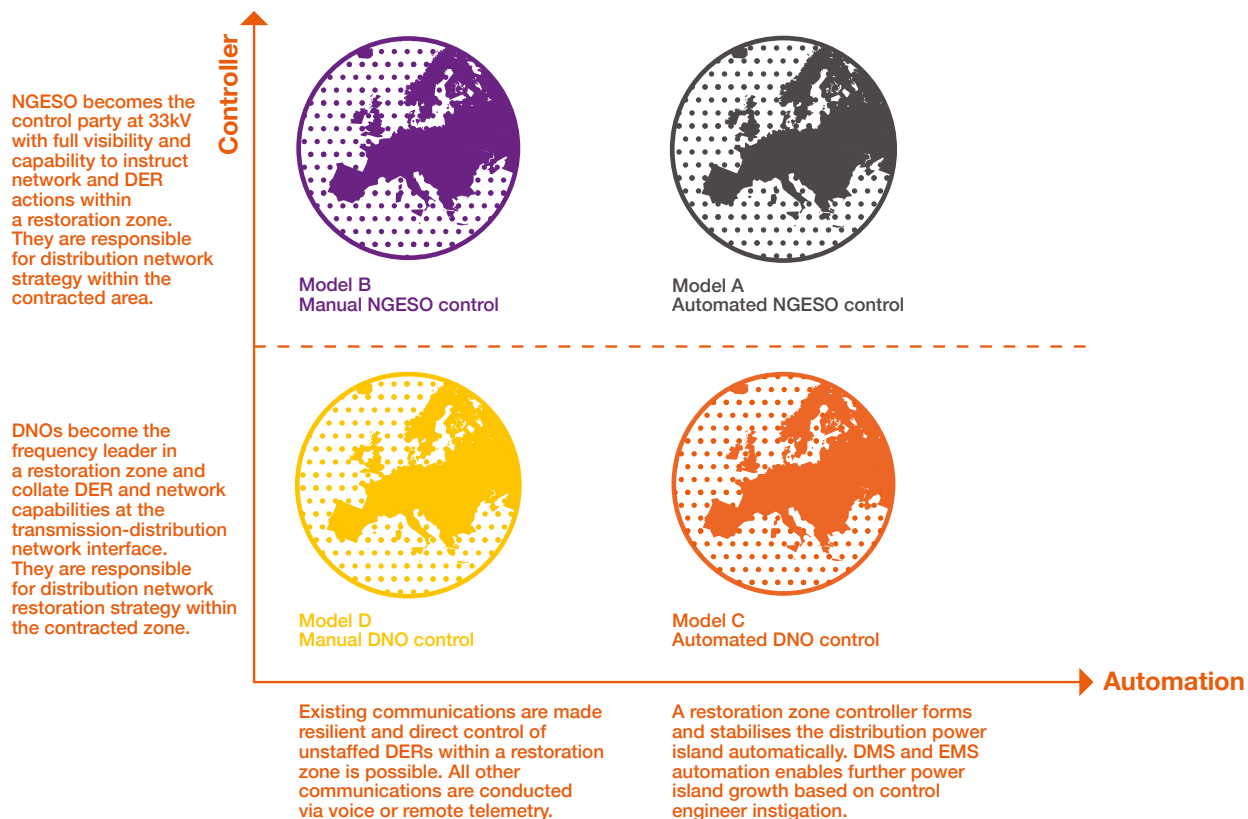

13.2.1 Automated NGENSO control

In this model, NGENSO control all aspects of a DER restart utilising automated systems to switch/instruct DNO and DER equipment as required. This is selected as the option with the highest level of automation and the least number of control interfaces. This option will involve an automated system such as a micro-grid controller that automatically manages the start-up of the DER and interaction with the loads or demands in the distribution network. It is anticipated that the micro-grid controller could reside either on the NGENSO or the DNO network. However, it may seem practical for it to reside on the DNO network with a requirement for this controller

to communicate with the NGENSO Energy Management System automatically. This would mean that communication devices would be required to achieve the data and signal exchange between the systems. The communication network infrastructure should be such that it supports the micro-grid communication requirements. This would include parameters such as bandwidth, network speed and security considerations.

There are three potential telecommunications infrastructure options that have been assessed to deliver the necessary voice and data requirements:

Figure 13.2

Figure showing Option A for automated NGENSO control

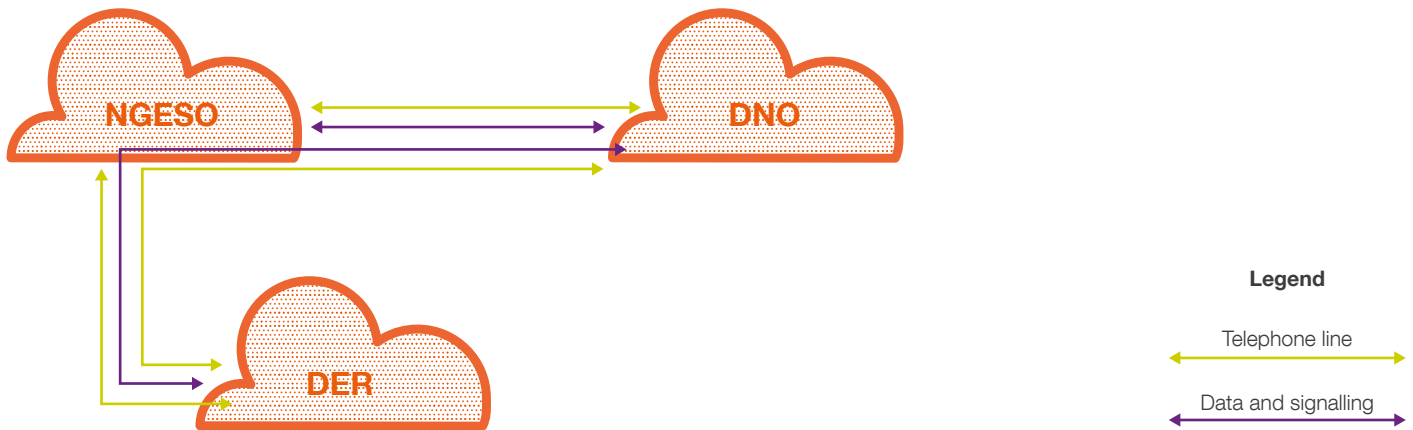

Option A

In this option, the OpTel network is extended to DERs to provide voice and data communication. It is anticipated that the OpTel network extension would be from the nearest or most practicable network node to the DER. This would take into consideration access rights between OpTel entry point to the DER, capacity and the cost of providing the infrastructure where applicable. The telecommunications infrastructure would provide telemetry and telephony line connections from the DER to NGENSO and vice versa.

The OpTel network is a fibre-based core network, hence the technology that would be used to extend to DER could likely include a fibre cable. Alternatively, a microwave solution could also be deployed. The use of satellite for telemetry could be limited to a voice solution as it may not support fast data switching in a micro-grid controller due to a higher satellite network latency.

Figure 13.3

Figure showing Option B for automated NGENSO control

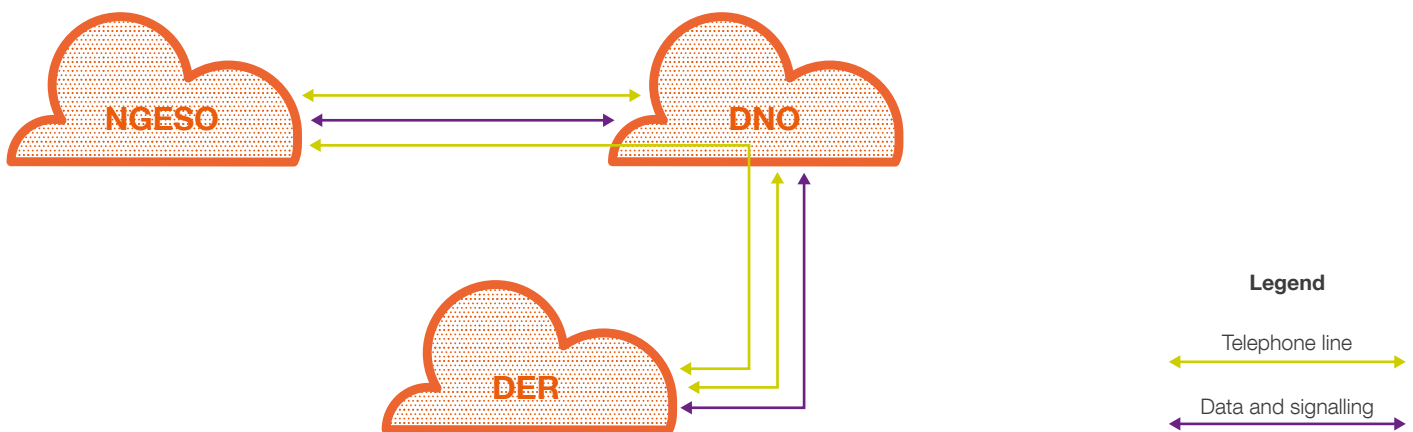

Option B

The DNO's network is used to provide the infrastructure to deliver voice and data connections to DER.

This option delivers data and voice capability to DERs by extending the DNO network. Currently, DERs of certain generating capacity (above 1 MW) provide telemetry data to DNOs using an existing network from the DNOs. The use of Openreach public switched telephone network (PSTN) lines for telephony is also prevalent. Voice calls could be routed over the data network (VOIP) as a replacement for traditional PSTN lines, noting that PSTN is planned to be phased out in 2025.

The DNO network to the DERs would require individual assessment to ensure that it has extra capacity to carry voice traffic, and the independent power resilience could require upgrading to meet the 72 hours of independent power autonomy required to support Black Start.

In cases where the network does not exist, DNOs would need to extend their network to DERs and this should meet the functional specification.

The technologies used by the DNOs are mostly fibre or microwave core network, but it may be cost effective and practical in some cases to utilise wireless technologies as alternatives. These include private LTE, and private radio (PMR). The base stations could be mounted on primary substations sites where they could subsequently benefit from the substation independent power resilience. The existing technology used by a DNO would largely influence the choice of technology that a DNO would deploy for Distributed ReStart.

Option C

This would use a combination of Option A and B to deliver voice and data solution. The option chosen would depend on factors such as practicality of delivery, cost, deployment time, terrain and technology familiarity. This could vary from DNO to DNO to support the unique features of the DNO.

13.2.2 Manual NGESO

NGESO coordinates all aspects of a DER, manually instructing the DNOs who carry out the switching on their own network. It does not make use of additional automated devices such as micro-grid controllers. However, it requires NGESO to have visibility of the DNO networks in order to carry out effective coordination.

ICCP links between the NGESO EMS and the DNO DMS would be required to ensure NGESO has visibility of the DNO networks.

The network infrastructure required for this model could use any of Options A, B, or C described earlier in the automated NGESO led process.

13.2.3 Automated DNO control

In this model, NGESO instructs DNOs to carry out power island growth up until energisation of the transmission system, after this point the power island acts similarly to an existing LJRP structure. DNOs would have access to an automated system for the management of power island growth and operation.

This model requires a micro-grid controller which would ideally reside in the DNO network to provide automated restoration options in the DNO network. There is need for communication from the DNO to NGESO and transmission operators once this is completed to connect to the transmission network. These communications could be carried over the telephone or via signalling between the systems with relevant handshakes in place.

The network infrastructure required could use any of Options A, B or C, however Option B, where the DNO extends its network to the DERs looks the most practical and suitable. The micro-grid controller, the connection to DERs and the switching devices are all utilising the DNO network, reducing issues around network latency and interoperability. It will also look to utilising existing network, though it may require upgrading in some cases.

13.2.4 Manual DNO control

In this model, NGESO instructs DNOs to carry out power island growth up until energisation of the transmission system and after this point, the power island acts similarly to an existing local joint restoration plan (LJRP) structure. This would not require a micro-grid controller for additional automation. DNOs would instruct DER providers to block load in a similar manner to the existing Black Start process, although distribution routes would be pre-identified, the DNOs have the flexibility to choose otherwise. Remote switching and segregation would be possible but all decision making on power island growth would rely on the DNO control engineer's judgement. DNOs would require an additional system for measuring systems frequency.

Option B is seen as the option with the least implementation time and cost and it mirrors the existing Black Start process. In this option, the DNO network is extended to DER site or if network already exists, it is upgraded to meet the independent power required for Black Start.

Figure 13.4
Figure showing Option B for a manual DNO control

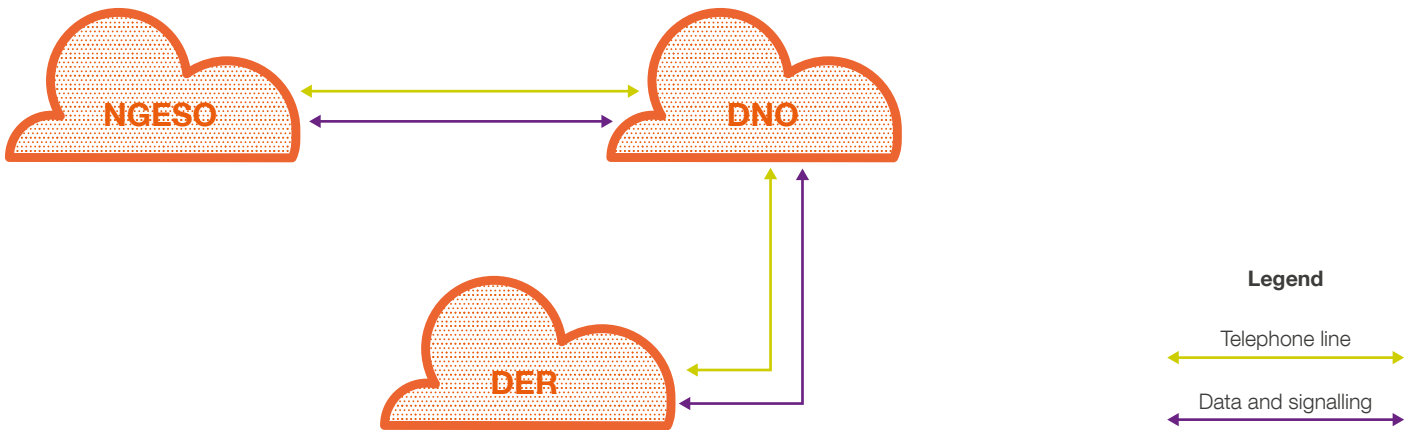

13.3 Summary of requirements

OST has reviewed the functional requirements of the OpTel and SPEN operational networks and is currently engaging the DNOs via the ENA Strategic Telecommunications Group to form a basis for the Distributed ReStart functional

requirements. In addition, input has been taken from existing Black Start procedures and specialists to identify information such as restoration timescales and strategy which informs the power resilience and capacity requirements.

The project is looking to capture the following technical and non-technical requirements.

Table 13.1

Table showing the technical requirements to be considered in OT design

Requirements	Description
Latency	The latency should be specified for protection and SCADA services
End-to-end delay	This defines the maximum allowable communication channel 'end-to-end' delay
Jitter	This defines the maximum permissible jitter
Manual switching	This will define the capability for manual and automatic switching
Specifications for communications protocol requirements	The requirements to specify the communication protocol that needs to be supported
Telephone user requirements	This defines the control centre and substation telephone user requirements
Compliance with standards	Requirement to comply with specific standards

Table 13.2

Table showing the non-technical considerations for OT design

Requirements	Description
End-to-end service availability	The end-to-end availability for a single-routed service
Service density protection	During normal operation, the maximum percentage of protection services to be carried on one physical communications link between any two nodes
Service density: SCADA, Operational Telephony and Operational Data	The maximum percentage of SCADA, Operational Telephony or Operational Data services to be carried on one physical communications link between any two nodes
Failure isolation procedures	The compliance with the principle of no knock-on failures and have proactive automatic shutdown procedures in place to prevent a failure of network equipment triggering mal-operation of other non-directly interconnected network equipment or systems within the application layer
Restoration of service	Priority to restoration of service
Physical separation design	Requirements for physical separation between specified separately routed telecommunication services along the entire route for cabled services
Segregation of circuits	Requirements for segregation of network for localised disaster events, such as storm damage, flooding etc., not to cause degradation of service
Location of equipment	Requirements for location of equipment securely and away from areas liable to flooding
Change of routes	Requirements for continued service operation where service route has changed, e.g. due to network failure or planned infrastructure change
Power source	Requirements for type of power source, redundancy and specifications
High voltage sites	Requirements for installations and safety at hot-site, which is any site above 11kV that is subject to rise of earth potential
Environmental performance	Requirements for environmental and test performance of equipment at High Voltage electrical substations
Equipment design	Requirements for equipment to work without error or degradation for the environmental conditions specified for these locations
Operation in extended temperature ranges	Requirements for equipment to work at certain temperatures
Earthing in substation telecommunications room	Requirements for earthing in substations
Electromagnetic compatibility (EMC) requirements	EMC requirements so it does not impair the performance of any other equipment in the substation by compromising the existing earthing arrangements
Mains independence	Requirements for mains independent electricity supplies to telecommunication rooms at substations and control centres
Safety and site access	Requirements for safe access to site and safety of equipment
Business Continuity and Disaster Recovery	Requirement for Business Continuity and Disaster Recovery procedures

13.4 Next steps

The project is currently designing the DRZC (as introduced in sections 5 and 10). Work is currently being carried out by several technology companies to produce a consolidated set of requirements for overall DRZC solutions, including requirements for the DRZ controller itself, DER, and any

other associated supporting systems. These requirements, and associated learning, will be presented in the next PET design stage report II and will be taken account of in the OST design stage report II where the draft functional specifications will be made available. Consultation will continue with Black Start participants as the functional requirements are refined, specifically through the ENA Strategic Telecommunications Group.

14. Cost analysis of meeting functional specification



An initial review of the relative costs of implementing the operational telecommunications by technology is presented in this section, together with an introduction to the next phase of cost assessment.

14.1. Introduction

To provide an indication of the possible costs of delivering operational telecommunications suitable for Distributed ReStart, OST has looked at the potential cost ranges for each technology and is in the process of gathering cost ranges for some case studies.

It is important to note that these costs are presented to provide some context and an indication of the potential costs of meeting the Distributed ReStart communication needs. The actual costs will be location specific and will vary significantly between sites.

We have provided indicative costs for implementing different technologies, recognising the variability introduced through existing telecommunications and site-specific requirements. These unknowns may have a significant bearing on which technology is appropriate in any particular case. Some site-specific costs can only be ascertained after site surveys. These costs include installation, professional services, design, excess construction charges.

The costs reflect the price of a new installation. Where there is already embedded infrastructure that can be leveraged, the costs will be dramatically different to a green field location where no infrastructure exists.

14.2 Cost ranges by technology

The relative costs of implementing the operational telecommunications technologies considered in the viability report have been explored further through the design stage. This exercise can only provide indicative cost ranges due to the dependency of total costs on the existing operational telecommunications, the terrain, the distance between end points, access routes, maximum user capacity and other business factors. Costs will consist of both capital costs and ongoing running costs, both of which are captured in table 14.1.

Table 14.1

Table of indicative costs for operational telecommunications solutions

Technology/Service	Set-up cost	Ongoing cost	Other costs – site dependent	Other considerations
Ethernet Access Direct (EAD)	Dual 2Mbps £5k–£10k, 1G circuit with 200Mbps service dual separation £50k–£60k	Managed services cost £5k–£70k	Professional services cost, type approval, excess construction charges	Service availability limited by radial distance constraints. Excess construction range for fibre is typically £50-£100 per metre. It may be a consideration to 'self-build' fibre extensions in some cases rather than pay for third party to extend their duct.
Multiprotocol label switching (MPLS)	Dual circuits £35k–£55k	Annual rental £10k–£15k	Excess construction charge, services cost	Can use EADs as access circuits. Backhaul can be via 3rd parties. Black Start resilience of end-to-end service. NB – MPLS is not necessarily a service or delivery mechanism in its own right – rather it is a sophisticated method for managing all types of IP traffic over any delivery medium (fibre, wireless, satellite etc). MPLS-TP is a specific variant which can satisfy teleprotection latency requirements. This is also subject to the infrastructure/network being accessible to the DER.
Satellite	Satellite hub – 2 x Ground Earth stations with existing RF uplink power and dish £700k–£850k Core satellite dish Fixed Earth station £350k–£450k Remote site VSAT dish £10k–£15k	Bandwidth charge 4 MHz satellite capacity £150k–£180k Managed services	Professional services, testing, planning permission, extra construction charges, dish mounting poles and concrete base	Where a satellite installation is already in use with adequate bandwidth, the additional cost may be for a remote site VSAT dish and other installation considerations. It is important to distinguish between VSAT (normally geostationary) and TSAT low earth orbit. VSAT typically has a 1.5m antenna at the end point – data rates of approx. 5 MB/s available but very expensive (can be of the order of £1,000 per day). Latency of around 1 second. Smaller TSAT/LEO systems typically has a 30cm x 30cm antenna). Much lower cost but maximum data rate around 2kB/s. Lack of SNMP v3 modems could be a cyber compliance issue. In addition, challenges may exist with the physical location of the receive antennas for embedded assets.
Microwave	£25k–£35k per link including: Active equipment Antennas Feeders Antenna mountings	Licence costs typically £3k per annum, managed service costs	Requires line of sight hence additional structures required to achieve height above obstructions can be costly with protracted planning regulations	It can be subject to 'new' obstructions during lifetime such as new builds or growth of fauna. It is also subject to the practicalities of antenna deployment at the embedded asset and the need to interconnect with a network for monitoring and control.
Fibre	Optical ground wire (OPGW)/optical phase conductor (OPPC) wire Circa £65k/km for overlay (majority of costs in labour and constraint charges) U/G fibre £40k/km to £120k/km	Managed service costs	Cost heavily dependent on geography of deployment with significantly greater costs associated with urban areas	Wayleaves generally restricted to DNO use only. As per EAD comment – may be preferable to own fibre assets than pay for capital investment in assets ultimately owned by Virgin, BT, Vodafone etc. Joint digs are an option with some fibre operators (City Fibre) – with dedicated sub-ducts made available specifically for the utility.
Private Radio	£2k–£5k per remote site equipment £10k–£20k per base station equipment	Spectrum cost, Network management costs Backhaul costs	Leased costs at third-party base station sites can be significant, circa £5k–£30k per annum Majority of costs are in the establishment of remote active assets where network access is shared across multiple use cases. New base station site build costs up to £100k. When co-located on existing site, build costs circa £40k Site lease costs can range £3k–£15k per annum	Band is limited via existed spectrum allocation. Increasingly, vendors in this area have a smaller global market. Increased risk that these proprietary 'vendor locked' solutions become stranded assets when technical support is withdrawn and/or supplier becomes insolvent (this has happened several times). Afford flexibility in terms of deployment and ease of scalability.

Technology/Service	Set-up cost	Ongoing cost	Other costs – site dependent	Other considerations
Private LTE	Remote site user equipment £2k–£5k per site eNB base station costs £20k–£50k per site EPCore £50k–£100k	Spectrum access costs Network management costs eNB interconnect and backhaul circuit costs	As private radio but potentially additional costs associated with the high capacity low latency backhaul circuits required	Currently no spectrum is assigned for deployment UK wide. Area of rapid growth outside the UK – favoured solution in Germany, Ireland, Denmark, Brazil. Global volumes should attract more vendors and reduce the cost per unit. Affords flexibility and ease of scalability from an asset connectivity perspective.
Emergency Services Network (ESN)	TBA	TBA	TBA	Ongoing uncertainty and delays regarding the eventual capability of this solution to satisfy original design specification (for blue light sector). Unlikely to be tailored to energy network operators' needs and operational resilience will be questionable as well as guaranteed QoS.
Private 5G	This is comparable to private LTE	This is comparable to private LTE	This is comparable to private LTE	Coverage limited at higher frequencies. Developments taking place in 3GPP but several years until solutions will be available which meet stringent utility requirements.
Fibre to the Premises	The service providers bear the cost of the enablement of FTTP for an area. User costs are associated with service connection Service connection is circa < £0.1k	Service rental costs, likely to be similar to MPLS less the EAD access rental charges of MPLS Circa £5k per annum	May require user to implement connectivity from the service access point of the service provider to the required point of presence within the users' site	Assumes a PON provision similar to Openreach but this might not be the case from other FTTP providers. FTTP is an access technology similar to EADs, required to be procured as a Black Start compliant service similar to MPLS and will be heavily dependent on availability.

The costs presented are intended to give an indicative cost of the technology and should not be used in making financial decisions to determine suitability of deploying any technology. In all cases, the cost of the overall end-to-end solution and the total cost of ownership should be considered in totality. Furthermore, there is a risk component to any solution that needs to take into account operational resilience in the context of mains power loss which is not always designed in to commercial/market based solutions.

Cost case studies are being developed for publication in the design stage report II against the functional specification for the operational models and the options within the models. These case studies will provide further indicative costing by considering roll-out to potential providers across a range of existing operational telecommunications topologies, terrains and geographical areas distributed amongst multiple DNOs.

14.3 Case studies

Both the DNOs and NGET own and operate 'private' operational telecommunications networks for the provision of existing voice and data services. These case studies consider the feasibility of providing the required Distributed ReStart operational communication via the respective networks.

Working with the ENASTG, a methodology was developed for collating the sample costs for communications that are compliant with the functional specification and roll-out options included within the four operational models.

14.4 DNO manual model

The template used for developing case study costs is illustrated below, this will be populated to provide overall costs for providing resilient operational telecommunications and is based on the agreed STG methodology.

Table 14.2

DNO manual model template

	Quantity modelled	1st installed cost (£k)	Annual operating cost (£k)	15 year lifetime cost (£k)	Lifetime cost variance (£k)	Solution description
Extension of NGET control telephony to DNO control room						
Provision of DNO telephony (wholly by DNO)						
DER control room						
DER sites						
DNO GSP substation						
DNO primary substation						
Totals		0.00	0.00	0.00	0.00	
Provision of DNO telephony (NGET OpTel backhaul circuits from GSP to DNO control room)						
NGET OpTel backhaul circuits from GSP to DNO control room						
DER control room						
DER sites						
DNO GSP substation						
DNO primary substation						
Totals		0.00	0.00	0.00	0.00	

Key

	To be populated by NGESO/NGET
	To be populated by DNO
	Calculated based on inputs

The following criteria are measured through this process:

- **Quantity modelled:** Indication of how many of each has been considered in formulating the response.
- **1st installed cost (£k):** The average cost to provide in the first instance, expressed in thousands.
- **Annual operating cost (£k):** The average cost to maintain and operate per annum, expressed in thousands.
- **15 year lifetime cost (£k):** The average cost to provide for 15 years including any anticipated asset or service refresh cost such as end of life replacement, expressed in thousands.
- **Lifetime cost variance (£k):** The maximum variance in costs from the average to provide for 15 years, expressed in thousands.
- **Solution description:** A description of how the requirement would be provided.

The required Distributed ReStart communications within the case study for this model are:

Extension of the NGET control telephony system to the DNO control room

For the case study, it is assumed that this would be undertaken by NGESO/NGET and hence costs for such would be provided by NGESO/NGET for each DNO. Some DNOs already have NGET control telephony within their respective control rooms.

Provision of DNO telephony to the following locations: DER control room

This is for the provision of a telephony service and instrument to the DNO point of presence at the DER site. It is assumed that the extension of the service across the DER infrastructure to the DER control room would be at the DERs cost subsequent to contracting for Distributed ReStart. This provision of a DER control room Black Start telephony is only applicable for manned DER sites which is likely to be limited to Anchor DERs. The provision of Black Start telephony to DER control rooms that are remote from the DER site has not been considered in the case study at this stage as the location is independent of the DNO operating area.

DER site

This is for the provision of a telephony service and instrument to the DNO point of presence at the DER site. It is assumed that the extension of the service across the DER infrastructure to the DER desired location would be at the DER's cost subsequent to contracting for Distributed ReStart.

DNO grid supply substation

This is for the provision of a telephony service and instrument to the DNO grid supply substation control room.

DNO primary substation

This is for the provision of a telephony service and a phone to the DNO primary substation control room. The case study considered two discrete options for the above provisions.

- **Provision of DNO telephony (wholly by DNO)**
This is the infrastructure used for the provision of the services when owned and operated by the DNO only. This does not preclude the use of third-party services within the provision of the services, only that the DNO is the 'owner' of the contractual undertaking with

the third-party in accordance with their policies and specifications for the use of such services.

- **Provision of DNO telephony (NGET OpTel backhaul circuits from GSP to DNO control room)**

This is the DNO, if cost effective, using the NGET OpTel network to connect between the DNO control room and the NGET substation at the GSP point of presence. The costs for the provision of such would be provided by NGET for each DNO.

14.5 NGESO manual model

The same template applies for the NGESO led model as displayed below.

Table 14.3

NGESO manual model template

	Quantity modelled	1st installed cost (£k)	Annual operating cost (£k)	15 year lifetime cost (£k)	Lifetime cost variance (£k)	Solution description
Extension of NGET control telephony to DNO control room						
Provision of NGESO telephony (wholly by NGESO)						
DER control room						
DER sites						
DNO GSP substation						
DNO primary substation						
Totals		0.00	0.00	0.00	0.00	
Provision of NGESO telephony (DNO backhaul circuits from DNO substation to NGET GSP)						
Provision of DNO backhaul circuits from DNO substation to NGET GSPs						
DER control room						
DER sites						
DNO GSP substation						
DNO primary substation						
Totals		0.00	0.00	0.00	0.00	

The required Distributed ReStart communications within the case study for this model are:

Extension of the NGET control telephony system to the DNO control room

The same description applies as for the DNO manual model.

Provision of NGESO telephony to the following locations: DER control room

This is for the provision of a telephony service and instrument to the boundary of the DER site. It is assumed that the extension of the service across the DER infrastructure to the DER control room would be at the DER's cost subsequent to contracting for Distributed ReStart.

Practically, this provision of DER control room Black Start telephony is only applicable for manned DER sites which is likely to be limited to Anchor DERs. The provision of Black Start telephony to DER control rooms that are remote from the DER site has not been considered in the case study at this stage as the location of such is independent of the NGESO operating area.

DER site

This is for the provision of a telephony service and instrument to the boundary of the DER site. It is assumed that the extension of the service across the DER infrastructure to the DER desired location would be at the DER's cost subsequent to contracting for Distributed ReStart.

DNO grid supply substation

The same as that for the DNO manual model.

DNO primary substation

The same definition applies as for the DNO manual model.

The case study considers two discrete options for the above provisions those being:

Provision of NGESO telephony (wholly by NGESO)

This is where the infrastructure used for the provision of the services is owned and operated by NGESO only. This does not preclude the use of third-party services within the provision of the services, only that NGESO is the 'owner' of the contractual undertaking with the third-party in accordance with their policies and specifications for the use of such services.

Provision of NGESO telephony (DNO backhaul circuits from DNO substation to NGET GSP)

If cost effective, NGESO could use the DNO network to connect between the DNO substation and the NGET GSP point of presence. The costs for the provision of such would be provided by DNO.

14.6 DNO automated model

For the DNO automated model, it is assumed that the telephony services set out in the DNO manual model will still be required for fall back should the automated system fail, hence the data as set out in the DNO manual model case study is pulled through for inclusion in the DNO automated model case study as illustrated below.

Table 14.4

DNO automated model template

	Quantity modelled	1st installed cost (£k)	Annual operating cost (£k)	15 year lifetime cost (£k)	Lifetime cost variance (£k)	Solution description
Extension of NGET control telephony to DNO control room	0	0.00	0.00	0.00	0.00	0
Provision of DNO telephony (wholly by DNO)						
DER control room	0	0.00	0.00	0.00	0.00	0
DER sites	0	0.00	0.00	0.00	0.00	0
DNO GSP substation	0	0.00	0.00	0.00	0.00	0
DNO primary substation	0	0.00	0.00	0.00	0.00	0
Totals		0.00	0.00	0.00	0.00	
Provision of DNO telephony (NGET OpTel backhaul circuits from GSP to DNO control room)						
NGET OpTel backhaul circuits from GSP to DNO control room	0	0.00	0.00	0.00	0.00	0
DER control room	0	0.00	0.00	0.00	0.00	0
DER sites	0	0.00	0.00	0.00	0.00	0
DNO GSP substation	0	0.00	0.00	0.00	0.00	0
DNO primary substation	0	0.00	0.00	0.00	0.00	0
Totals		0.00	0.00	0.00	0.00	
Interconnect of NGESO EMS with DNO DMS						
Provision of DNO data services (wholly by DNO)						
DER sites to DNO GSP substation						
DNO DMS to DNO GSP substation						
DNO primary substation to DNO GSP substation						
Totals		0.00	0.00	0.00	0.00	

Quantity modelled	1st installed cost (£k)	Annual operating cost (£k)	15 year lifetime cost (£k)	Lifetime cost variance (£k)	Solution description
-------------------	-------------------------	----------------------------	----------------------------	-----------------------------	----------------------

Provision of DNO data services (NGET OpTel backhaul circuits from GSP to DNO control room)

NGET OpTel backhaul circuits from GSP to DNO control room	0	0.00	0.00	0.00	0.00	0
DER sites to DNO GSP substation	0	0.00	0.00	0.00	0.00	0
DNO DMS to DNO GSP substation	0	0.00	0.00	0.00	0.00	0
DNO primary substation to DNO GSP substation	0	0.00	0.00	0.00	0.00	0
Totals		0.00	0.00	0.00	0.00	

Provision of DNO voice and data services (wholly by DNO)		0.00	0.00	0.00	0.00	
Provision of DNO voice and data services (NGET OpTel backhaul circuits from GSP to DNO control room)		0.00	0.00	0.00	0.00	

The key remains the same as that for the previous manual model case studies with the following additions:

- Provision of DNO voice and data services (wholly by DNO):
 - The sum of the provision of DNO telephony (wholly by DNO) plus provision of DNO data (wholly by DNO).
- Provision of DNO voice and data services (NGET OpTel backhaul circuits from GSP to DNO control room):
 - The sum of provision of DNO telephony (NGET OpTel backhaul circuits from GSP to DNO control room) plus provision of DNO data services (NGET OpTel backhaul circuits from GSP to DNO control room).

The additional Distributed ReStart communications (above those of the DNO manual model) within the case study for this model are:

Interconnection of NGESO EMS with DNO DMS

For the case study, it is assumed that this would be undertaken by NGESO and hence costs for such would be provided by NGESO/NGET for each DNO. Some DNOs already have interconnection between the NGESO EMS and the DNO DMS.

Provision of DNO data services

For the case study, it is assumed that the Distributed ReStart Zone controller (DRZC) would be located at the DNO grid supply point (GSP) and that it is this device that has primary command and control over the restart of the power island associated with the specific DNO GSP. The DNO data services specified here reflect the likely worst-case data communications requirements of a DRZC between the following locations.

DER sites to DNO GSP substation

This is for the provision of data services from the DNO substation point of presence at the DER site to the DRZC located at the DNO GSP substation. Extension of these services across the DER site to the point of interconnection with the DER control system is assumed to be at the cost

of the DER, subsequent to contract for Distributed ReStart services. The data services required in this instance are assumed to be 10Mbps CAT1 (Fast Response) IP/Ethernet service.

DNO DMS to DNO GSP substation

This is for the provision of data services from the DNO DMS to the DRZC located at the DNO GSP substation. The data service required in this instance is assumed to be 2Mbps E1 ICCP connection.

DNO primary substation to DNO/NGESO GSP substation

This is for the provision of data services from the DNO primary substation remote terminal unit (RTU) to the DRZC located at the DNO GSP substation. The data services required in this instance are assumed to be 10Mbps CAT1 (Fast Response) IP/Ethernet service.

The case study considers two discrete options for the above provisions:

Provision of DNO data services (wholly by DNO)

As was the case for the provision of DNO telephony of the manual model case study, the infrastructure used for the provision of the services is owned and operated by the DNO only. This does not preclude the use of third-party services within the provision of the services, only that the DNO is the 'owner' of the contractual undertaking with the third-party in accordance with their policies and specifications for the use of such services.

Provision of DNO data services (DNO backhaul circuits from DNO substation to NGET GSP)

As was the case for the provision of DNO telephony of the manual mode case study, the DNO, if cost effective, could use the NGET OpTel network to connect between the DNO control room and the NGET substation at the GSP point of presence. The costs for the provision of such would be provided by NGESO/NGET for each DNO.

14.7 NGESO automated model

For the DNO automated model it is assumed that the telephony services set out in the DNO manual model

will still be required for fall back should the automated system fail, hence the data as set out in the DNO manual model case study is pulled through for inclusion in the DNO automated model case study as illustrated below.

Table 14.5

DNO automated model template

	Quantity modelled	1st installed cost (£k)	Annual operating cost (£k)	15 year lifetime cost (£k)	Lifetime cost variance (£k)	Solution description
Extension of NGET control telephony to DNO control room	0	0.00	0.00	0.00	0.00	0
Provision of NGESO telephony (wholly by NGESO)						
DER control room	0	0.00	0.00	0.00	0.00	0
DER sites	0	0.00	0.00	0.00	0.00	0
DNO GSP substation	0	0.00	0.00	0.00	0.00	0
DNO primary substation	0	0.00	0.00	0.00	0.00	0
Totals		0.00	0.00	0.00	0.00	
Provision of NGESO telephony (DNO backhaul circuits from DNO substation to NGET GSP)						
Provision of DNO backhaul circuits from DNO substation to NGET GSPs	0	0.00	0.00	0.00	0.00	0
DER control room	0	0.00	0.00	0.00	0.00	0
DER sites	0	0.00	0.00	0.00	0.00	0
DNO GSP substation	0	0.00	0.00	0.00	0.00	0
DNO primary substation	0	0.00	0.00	0.00	0.00	0
Totals		0.00	0.00	0.00	0.00	
Interconnect of NGESO EMS with DNO DMS						
Provision of NGESO data services (wholly by NGESO)						
DER sites to DNO GSP substation						
DNO DMS to DNO GSP substation						
DNO primary substation to DNO GSP substation						
Totals		0.00	0.00	0.00	0.00	
Provision of NGESO data services (DNO backhaul circuits from NGET GSP to DNO PoP)						
NGET OpTel backhaul circuits from GTS to NGESO control room	0	0.00	0.00	0.00	0.00	0
DER sites to NGET GSP substation	0	0.00	0.00	0.00	0.00	0
DNO DMS to NGET GSP substation	0	0.00	0.00	0.00	0.00	0
DNO primary substation to NGET GSP substation	0	0.00	0.00	0.00	0.00	0
Totals		0.00	0.00	0.00	0.00	
Provision of NGESO voice and data services (wholly by DNO)		0.00	0.00	0.00	0.00	
Provision of NGESO voice and data services (DNO backhaul circuits from NGET GSP to DNO PoP)		0.00	0.00	0.00	0.00	

The key remains the same as that for the previous manual model case studies with the following additions:

- Provision of NGENSO voice and data services (wholly by DNO):
 - The sum of the provision of NGENSO telephony (wholly by NGENSO) plus provision of NGENSO data (wholly by NGENSO).
- Provision of NGENSO voice and data services (DNO backhaul circuits from NGET GSP to DNO point of presence (PoP)):
 - The sum of provision of NGENSO telephony (DNO backhaul circuits from DNO substation to NGET GSP) plus provision of NGENSO data services (DNO backhaul circuits from NGET GSP to DNO PoP).

The additional Distributed ReStart communications (above those of the NGENSO manual model) within the case study for this model are:

Interconnection of NGENSO EMS with DNO DMS

The same as that for the DNO automated model.

Provision of NGENSO data services

Similar to the DNO automated model case study, it is assumed that DRZC would be located at the NGET GSP and that it is this device that has primary command and control over the restart of the power island associated with the specific NGENSO GSP. The DNO data services specified here reflect the likely worst-case data communications requirements of a DRZC between the following locations.

DER sites to NGET GSP substation

This is for the provision of data service from the boundary of the DER site to the DRZC located at the NGET GSP substation. Extension of these services across the DER site to the point of interconnection with the DER control system is assumed to be at the cost of the DER, subsequent to contract for Distributed ReStart services. The data service required in this instance is the same as for the DNO automated model case study.

DNO DMS to NGET GSP substation

This is for the provision of data service from the DNO DMS to the DRZC if located at the NGET GSP substation. The data service required in this instance is the same as for the DNO automated model case study.

DNO primary substation to NGET GSP substation

This is for the provision of data service from the DNO primary substation RTU to the DRZC located at the NGET GSP substation. The data service required in this instance is the same as for the DNO automated model case study.

The case study considers two discrete options for the above provisions those being:

Provision of NGENSO data services (wholly by DNO)

As was the case for the provision of NGENSO telephony of the manual model case study, the infrastructure used for the provision of the services is owned and operated by NGENSO only. This does not preclude the use of third-party services within the provision of the services only that NGENSO is the 'owner' of the contractual undertaking with the third-party in accordance with their policies and specifications for the use of such services.

Provision of NGENSO data services (DNO backhaul circuits from NGET GSP to DNO PoP)

As was the case for the provision of NGENSO telephony of the manual model case study, NGENSO, if cost effective, could use the DNO network to connect between the DNO substation and the NGET GSP point of presence. The costs for the provision of such would be provided by DNO.

14.8 Central model

The communication requirements for the central model are the same as the DNO automated model hence a dedicated case study is not required at this point as the case study for the DNO automated model can be applied.

14.9 Next steps

At the time of writing, case studies have been compiled for two DNOs. Next steps will be to collate the data from all respondents and summarise the outputs in terms of variations in costs and technologies for each of the case study types. This information will then be included in the design stage II report due for publication at the end of 2020.



In this section, we discuss the approach to, and findings of, an assessment of the cyber security risks associated with the telecommunications options and control models being considered as part of the Distributed ReStart project.

15.1 Introduction

The project has identified the need for a degree of automation to be introduced to reduce the workforce burden and mitigate against power engineering risks, hence introducing the Distributed ReStart Zone controller (DRZC). The objective of this control scheme is to establish a power island at a grid supply point with an appropriate workflow to enable initial energisation, connection and dispatch of DERs, and restoration of local demand. Once the power island is established, the goal is to harness the collective capabilities of the Anchor DER, other DER providing support services, and flexible demand to maintain stability and provide capability at the point of connection to support wider network restoration.

15.2 Overview

15.2.1 Why undertake a cyber risk assessment?

Changes in the energy industry have the potential to increase the attack surface and may lead to changes in the levels of cyber security risk. Decentralisation, driven by decarbonisation and digitisation, is generating new interdependencies between energy market players, which can also present new cyber security risks as systems become more interconnected and data is shared more widely.

One of the most significant challenges associated with introducing DERs into the Distributed ReStart process is that operational systems and telecommunications networks will become more interconnected than they are currently. This requirement is driven by the need to provide voice and data connectivity to a larger number of key stakeholders, including DNOs and DERs, to provide situational awareness and enable coordination between them in order to deliver a Distributed ReStart.

In order to determine the levels of risk associated with the telecommunications options and control models currently being considered by the project, this risk assessment sought to understand the cyber security risks to the electricity system in the future.

15.2.2 The cyber risk assessment context for Distributed ReStart

By assessing the risk and identifying key mitigations in the early stages of the project and ensuring the solution is secure-by-design, the overall industry risk associated with a Distributed ReStart can be reduced to an acceptable and proportionate level. This critical step will help ensure that the end-to-end Distributed ReStart capability remains resilient now and into the future.

The cyber risk assessment looks at the motivation and intent of various threat actors, the key risks and their likely impact on the Distributed ReStart process. The risk assessment has considered each of the proposed telecommunications options and control models and will be used to help:

- target the investment which will be required to reduce the industry's cyber security risk to an acceptable level
- ensure the end-to-end solution is cyber-resilient by assessing the risk to key components and the overall system
- establish roles and responsibilities for each Distributed ReStart stakeholder
- inform the development of a baseline minimum level of security required across all players which is proportionate to the level of cyber risk.

15.3 Threat assessment

The threat assessment establishes the threat sources, their level of motivation and the capability they would need to execute a successful cyber attack against the Distributed ReStart capability.

15.3.1 Threat landscape

A series of previous cyber attacks on international energy infrastructures were assessed, together with a future looking view on trends in the threat landscape, which has informed our analysis.

The energy industry attack surface is expanding, driven by key trends such as digitisation and decentralisation. Given the level of impact or financial gain which could be achieved by mounting a successful cyber attack, highly skilled threats and organised criminal groups are looking for attractive targets such as energy infrastructure.

The wider threat landscape has also seen several notable incidents, which demonstrate how global geopolitical factors may influence the behaviour of threat actors and how rapidly the situation can evolve:

- The Shamoon attacks on oil and gas organisations in Saudi Arabia and UAE.
- CrashOverride which caused a blackout in part of the Ukrainian capital city.
- The cyber attack on Elexon, who play an important role in the operation of the UK electricity market.
- The ransomware attack on Energias de Portugal (EDP), the Portuguese wind power company.
- The recent sustained and large-scale cyber attacks on Australia.

These attacks have demonstrated how attackers may seek to exploit weaknesses in systems to target key infrastructure as well as pre-position themselves before launching future attacks. In some cases, this capability can lie dormant until the hostile actor decides to utilise it to mount an attack.

Our assessment included an analysis of several high-profile cyber attacks, including CrashOverride, Triton, Shamoon, Dragonfly and several others. These cyber attacks were identified as they have all been used previously to exploit critical energy infrastructure operators and associated operational technologies.

15.3.2 Capability and motivation

Our analysis found that some organised groups have the required capability and resources available to craft and execute cyber attacks against the technologies high underpin Distributed ReStart.

Threat sources are willing to expend significant time and resources in order to gather information that may be useful in pre-positioning and developing future attacks on critical infrastructure. The tools used for cyber-espionage are highly sophisticated and often make use of advanced techniques with the aim of remaining undetected.

There have been several highly sophisticated and targeted attacks which exploit vulnerabilities in operational technologies/industrial control systems used within international critical energy infrastructure. Threat sources may attempt to use variants of these types of attack to target the Distributed ReStart capability.

It is important that all new systems and components to be deployed consider security from the outset. By taking this approach, it is possible to ensure that the networks remain resilient to the threats identified and are available, operating as designed, in the unlikely event that they are needed.

15.3.3 Trends 2025 to 2030

There are several key trends which will increase the cyber security threat level and attack surface between now and 2030. The evolution of threat actor capability and technology trends are considered as part of the analysis.

The key trends are digitalisation, disruptive technologies and accelerated cyber threats.

- Digitalisation is the transformation of operational, business and other processes through the use of data. Digitalisation is underpinned by a number of technological developments including 5G, digital twins, internet of things and cloud computing.
- Potentially disruptive technologies include artificial intelligence and quantum computing where there is a possibility of a significant and disruptive step change in capability.
- Accelerated cyber threats are likely to be driven by the potential for financial gain (for cyber criminals) and interference/disruption of national infrastructures (including democratic processes, media outlets and power grids) by nation state actors.

From a cyber security risk perspective this means the landscape could change rapidly with significant increases in cyber security risk happening over a relatively short and unpredictable timeframe.

Highly sophisticated threat actors: The most sophisticated threat actors are likely to continue the use of cyber espionage and cyber attacks to further their own political, strategic and economic objectives. The levels of investment in developing cyber capability are likely to grow as these actors look to develop offensive cyber capability targeting media, telecommunications, and critical energy infrastructure. It is also possible that some actors will seek to monetise attacks on critical energy infrastructure through the use of novel ransomware attacks or the threat of conducting an attack.

Digital twins/internet of things (IoT): Driven by digitisation, both digital twins and IoT will grow significantly to yield benefits such as predictive maintenance, process optimisation and energy efficiency. These technologies will increasingly be used as part of the smart energy ecosystem. However, both technologies expand the potential attack surface and are likely to be used by sophisticated actors to undertake attacks. IoT devices have already been successfully used to generate botnets and it is feasible to use them to mount an attack on the grid (e.g. a co-ordinated mass switch on or off event impacting the stability of supply).

5G: The 5G network supports features such as network slicing which, as 5G matures, may be used for certain elements of critical energy infrastructure given the defined service level agreement (SLA) and performance offered. The likely pace of 5G deployment and maturity means this is unlikely to be a consideration until the late 2020s.

Cloud computing: The use of cloud computing for critical energy infrastructure has the potential to grow as cloud brokering services mature. The adoption is likely to be partial and limited to non-critical services such as data analytics and back office functions due to security and resilience concerns.

Artificial intelligence (AI): AI presents a potentially significant range of both threats and opportunities. AI based techniques are already being used to analyse cyber attacks on internet and telecommunications infrastructure. AI can also be used to generate next generation malware or to co-ordinate botnet based cyber attacks.

Quantum computing: The use of quantum computing is likely to accelerate and become more mainstream over the 2025-2030 timeframe. This may present challenges to existing cryptographic methods which may become easier to crack in a reasonable timeframe.

15.4 Cyber security risk assessment

The cyber security risk assessment used a structured approach to establish how the identified threat sources could attack each of the proposed control models for Distributed ReStart. The risk assessment allows the level of risk associated with each model to be established and mitigations can be considered to reduce risks in a cost proportionate manner.

Figure 15.1
Top level overview of the risk assessment process



The overall qualitative risk associated with each of the identified models was determined as a function of the likelihood of an event occurring and the potential impact.

Figure 15.2
Control model options

<p>Model A – NGENSO automated</p> <p>Automatic control functionality is provided by NGENSO. This would centralise all control of UK transmission and distribution networks within NGENSO, including controlling DER and DNO equipment, as required, to build power islands (or DRZs) that can ultimately be used to energise the UK transmission network.</p> <p>This model requires that telemetry data from both the DNO networks and the DERs is made available to the NGENSO owned/operated micro-grid controllers.</p>	<p>Model B – NGENSO manual</p> <p>Control of the distribution networks and DERs is centrally co-ordinated from NGENSO, with instructions issued by voice communications to DNOs and DERs.</p> <p>This requires telecommunications links with the DNOs and DERs to instruct operations (e.g. switching/loading).</p> <p>This model requires that telemetry data from both the distribution networks and the DERs is made available at the NGENSO control centre.</p>
<p>Model C – DNO automated</p> <p>Automatic control functionality is included within the distribution networks.</p> <p>Telemetry and communications would be required by the DNO for all DERs in scope as well as for the distribution network itself.</p> <p>Additionally, telemetry and communications data would be required to be shared with NGENSO to aid coordination of transmission network switching actions.</p>	<p>Model D – DNO manual</p> <p>Control of the distribution networks and instructing DERs of demand is undertaken manually by DNOs using voice communications.</p> <p>This option requires access to telemetry data from the DERs and the DRZ itself.</p>

15.4.1 Methodology and approach

The methodology used for the risk assessment was developed in line with NIST Special Publication 800-30 – Guide for Conducting Risk Assessments, tailored to the specific requirements of the project. Preparing for the risk assessment involved establishing the purpose, scope, assumptions and constraints prior to conducting the process. Reference material to support the risk assessment was also identified to support the analysis.

The risk assessment process is shown in figure 15.1 below:

15.4.2 Control models

Several control models for delivering a Distributed ReStart have been developed as part of the project, each of which requires that either NGENSO or the DNOs (including Scottish Transmission Operators) are able to lead the Distributed ReStart for the Distributed Restoration Zones (DRZs) for which they are responsible. A summary of the four different control models is summarised in figure 15.2.

There are three telecommunications network options being considered [11] by the Distributed ReStart project:

- **Option 1: Extend the existing National Grid operational telecommunications network directly to all DERs.** This method would require that additional connectivity be provided from National Grid's telecommunications network to DER sites. Separate communication links would also be maintained to DNOs and Scottish Transmission Owners (e.g. to control centres). In cases where DNOs lead the restoration, communications could be routed using National Grid's extended network.
- **Option 2: Extend the existing DNO networks to DER sites.** DNOs may already have existing connectivity to DER sites or have their own distribution network equipment (e.g. substation equipment) which can be extended to the DER. In cases where NGESO leads the restoration, the DNO will essentially act as a bearer to enable National Grid's network to be extended to all DER sites.

- **Option 3: Take a hybrid approach.** Utilise both National Grid and DNO operational networks to provide connectivity to DER sites.

A cyber risk assessment for each control model and variations was used to establish the level of risk for each option. The threat sources, motivation and capability were used to establish the impact and likelihood of an attack and hence calculate the risk.

15.4.3 Telecommunications options

To deliver a successful Distributed ReStart, NGESO and Distribution Network Operators (DNOs) will require new telecommunications connectivity to be established with multiple DERs. A study of the existing networks has already been conducted and several communications options have been identified which may be suitable to provide connectivity to DERs.

The options currently being considered are summarised in figure 15.3.

Figure 15.3
Telecommunications options

Technology type	Telecommunications network	Public	Private	Point to point
Satellite	Private VSAT		✓	
Wireless	Microwave radio		✓	✓
	Private radio		✓	
	Private LTE		✓	
	Private 5G		✓	
	Public 5G	✓		
Fixed	Private fibre optic services		✓	✓
	Ethernet services		✓	✓
	Fibre to the premises (FTTP)	✓		

15.4.4 Key insights from the risk assessments

Distributed ReStart will require NGESO and DNOs to move to a new control model, underpinned by communication links and/or micro-grid controllers. Distributed ReStart is underpinned by a range of existing core systems which are also considered as part of the risk assessment.

The findings from the risk assessment will be used to inform the future stages of the project, helping to ensure that capability is resilient to the evolving cyber security threat and is secure-by-design.

15.5 Mitigations

The cyber security risk assessment allows the level of risk associated with each threat source and event to be estimated such that more significant risks can be addressed and mitigated to an acceptable level.

The assessment has been used to generate a list of candidate mitigations which aim to lower the inherent risks to an acceptable level. The cost proportionality of controls can also be assessed, allowing the specific targeting of investments in cyber-resilience to reduce risks to an acceptable level.

A range of candidate mitigations have been identified, which build upon foundations that are established within the industry and may be extended to include new stakeholders within the Distributed ReStart space. The mitigations identified incorporate current good practice and include physical, personnel, procedural and technological security mitigations.

The focus at this stage is to ensure that the components and networks which comprise the end-to-end capability are able to fulfil their key requirements, having high levels of integrity and availability, as well as being resilient to the most capable cyber threats.

15.6 Conclusions

Our conclusion is that Distributed ReStart must be adequately secure to reduce risk faced by an evolving threat. If unmitigated, the level of risk is likely to increase over time driven by technological innovation, the inclusion of new generation sources and accelerated cyber threats. Appropriate and proportionate mitigations will be required to manage the risk.

Undertaking a risk assessment allows investments in cyber-resilience to be targeted to give the best return on investment by reducing risks to an acceptable level and providing value for money to the consumer.

15.6.1 The threat landscape is evolving and could be subject to disruptive change

Our analysis of the cyber threat landscape demonstrates the need to secure Distributed ReStart to reduce the risks faced by an evolving threat. The macro level trends we identified in technology, digitalisation and accelerating cyber threats suggest that rapid and unforeseen changes in the cyber security landscape could occur between now and 2030.

Our risk assessment of the control and telecommunications options for Distributed ReStart allows the likelihood and impact of potential threats and threat sources to be estimated. The level of risk associated with each option can be understood, allowing lower risk options to be considered in more depth. The risk assessment considers the evolving threat landscape through to 2030 to ensure trends are appropriately considered.

15.6.2 Investing in cyber-resilience

The evolving cyber threat landscape and level of cyber security risk can be addressed for Distributed ReStart through a set of mitigations and controls. The candidate mitigations which have been identified cover the main areas of risk around the supply chain, 3rd parties, people, process and technology. All these mitigations will come with an associated cost and will result in a certain level of risk reduction (benefit).

Mitigations can be assessed using a cost/benefit analysis to achieve an acceptable level of residual risk which protects Distributed ReStart against a wide range of potential cyber attacks in a cost proportionate manner. The level of cyber threat and potentially rapid changes in the cyber security landscape mean that investing in cyber-resilience will be essential to protect Distributed ReStart.

15.6.3 Next steps

The next steps for the project will include continuing to assess the risk as the Distributed ReStart project evolves, engaging stakeholders across the industry, but, most importantly, ensuring a robust and resilient Distributed ReStart capability now and in the future.



Developments within the Distributed ReStart project and externally will inform the next phases of analysis.

16.1 Introduction

During the design stage, we have worked closely with the Power Engineering and Trials (PET) and Procurement and Compliance (P&C) workstreams to build on the outputs from the viability stage and define processes and requirements that will form part of a coherent design. We have also gained valuable challenge and insight from external stakeholders to allow us to take account of the rapid changes ongoing in the electricity and telecommunications industries.

16.2 Design stage report II

We have chosen to split the design stage reports into two. This report being design stage report I, with a second report 'design stage report II' to be published in late 2020. This allows us to ensure a consistent approach that takes account of some important pieces of work that will become available in the near future.

Some of the key information with which we need to align over the coming months are:

1. The DRZ controller design (as described in sections 5 and section 10).

Work is currently being undertaken by several technology companies to produce a consolidated set of requirements for overall DRZC solutions, including requirements for the DRZ controller itself, DER, and any other associated supporting systems. These requirements, and associated learning, will be presented in the PET design stage report II, published towards the end of 2020.

2. New industry guidance. In particular:
 - the DER Cyber Security Connection Guidance, which is now complete and, at the time of going to print, was due to be published by BEIS in September (described in section 2) and
 - the ENASTG Operational Telecommunications Standard for Connected Distributed Generation and Storage (which is due out in the coming months).

Both are key pieces of guidance with which OST will seek to align any functional specification for Distributed ReStart.

3. Further cyber security analysis of existing communications networks, traffic, fault data and systems interfacing requirements.

Distributed ReStart



Systems and DER interfaces

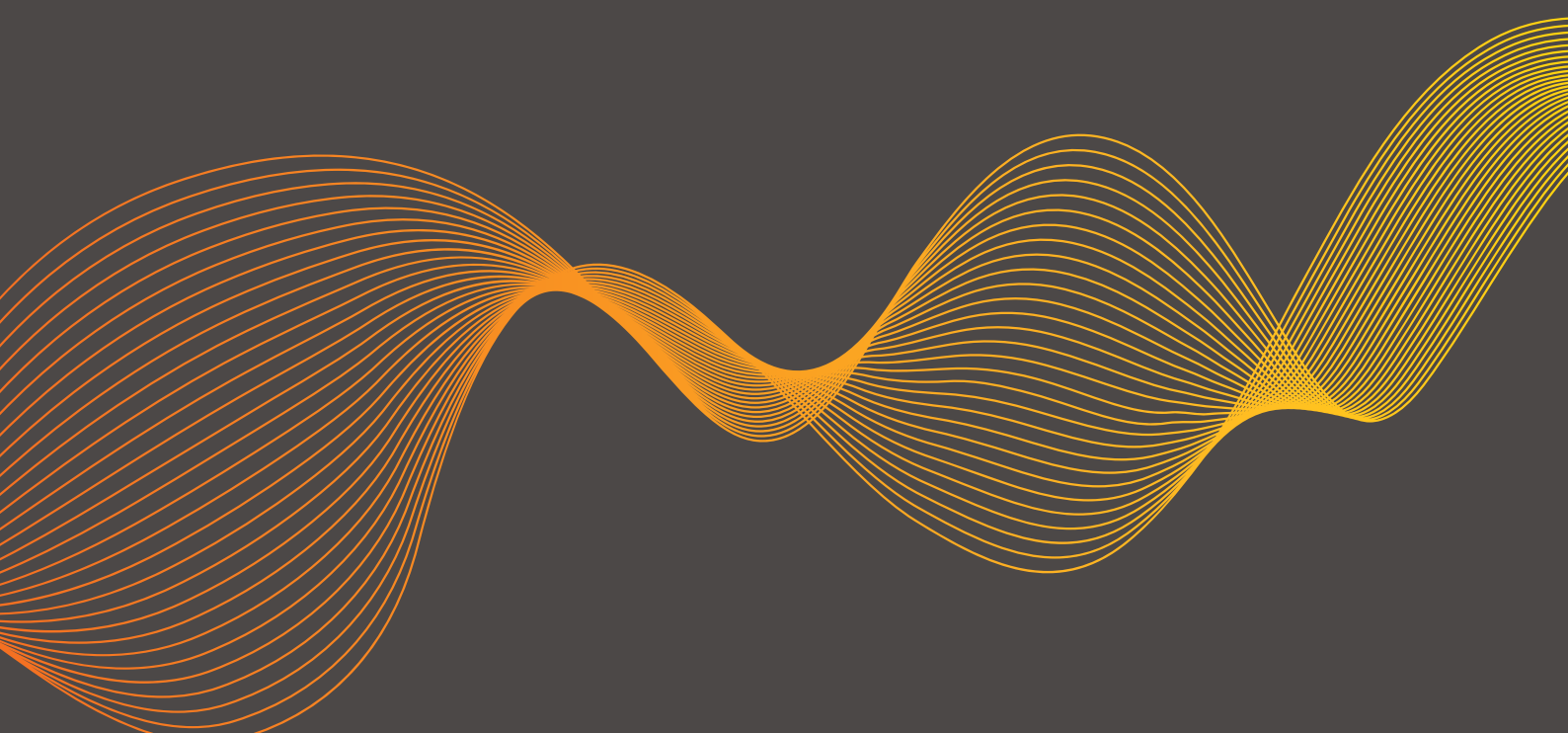



Systems are essential to the efficiency and ease of managing the restoration of power to the grid safely and efficiently.

17.1 Approach to design stage

The systems and applications used by National Grid ESO, the TOs and DNOs were discussed in our viability report. These systems aid the power system engineers to manage and control the operation of the power system and are classified as essential to the operation and management of Black Start. They present crucial data to provide situational awareness to the power system engineers.

In this design report, the systems considered essential to managing Distributed ReStart have been identified, using existing systems used by Black Start participants as a starting point.

The required systems are aligned to the four organisational models considered earlier in this report (NGESO led automated, NGESO led manual, DNO led automated and DNO led manual).

17.2 System requirements

The systems that have been identified to enable Distributed ReStart are listed by organisational model. This is not an exhaustive list, as more system requirements could be identified as the project moves into the refine stage of the project.

Table 17.1

Systems required for automated NGESO control

System	Location	Current state/notes
Integrated Energy Management System (IEMS)	NGESO, TSO	This is currently in place.
Distribution Energy Management System (DMS)	DNOs	This is currently in place.
DRZ Controller	DNOs or NGESO	This will depend on the design specifications.
ICCP	Connecting NGESO IEMS and DNOs DMS	This is partially deployed. This will need to be deployed to all DNOs.
Frequency Measurement Devices	NGESO and DNOs	This will be required to be deployed to all DNOs and incorporated as part of the micro-grid solution.

17.2.2 Manual NGESO control

The manual NGESO control model is considered to closely align with the current Black Start process. Hence the systems relied upon for the traditional Black Start process will be used.

The ICCP link, which provides connectivity and enables exchange of data between systems, though not a system, has been included here to reflect its importance in achieving data transfer, signalling and control from the systems to the rest of the power system equipment.

17.2.1 Automated NGESO control

The system required for the automated NGESO control is listed in the table below. There are two notable additions when compared to the requirement for the traditional Black Start.

Inter-control centre communication protocol (ICCP):

This is considered to be a mandatory requirement between the NGESO IEMS and all the DNOs DMS systems to enable the model to effectively restart the power system. The ICCP link will enable visibility of the telemetry data from the DNO and DER networks. The ICCP link will also enable signalling and control action to be taken by NGESO. This will also provide the same functionality to the micro-grid controller.

DRZ controller (DRZC): The controller is introduced in the automated models (see section 5) to manage and control the Distributed ReStart Zone (DRZ). The DRZC, depending on the design configuration, can reside on either the NGESO or DNO networks. Where it resides on the NGESO network, the ICCP link will provide the interface for data exchange, signalling and control of the elements on the DNO networks.

The ICCP link is considered as additional requirement, essential to enable NGESO to have additional overview of the DER telemetry data.

In addition to the systems, the number of frequency measuring points will need to be increased to enable greater measurement granularity so NGESO can manage the extra DERs for restoration.

Table 17.2

Systems required for manual NGESO control

System	Location	Current state/notes
Integrated Energy Management System (IEMS)	NGESO, TSO	This is currently in place.
Distribution Energy Management System (DMS)	DNOs	This is currently in place.
ICCP	Connecting NGESO IEMS and DNOs DMS	This is partially deployed. This will need to be deployed to all DNOs.
Frequency Measurement Devices	NGESO	NGESO will need to increase the number of measuring devices.

17.2.3 Automated DNO control

The control systems required for the automated DNO control model align more closely to the automated NGESO models than the manual controls. The notable difference between the DNO automated and NGESO automated models is the location of the DRZC and the control of frequency measuring devices.

For this model, the DRZC is most suitably located in the DNO network. As we move into the refine stage, further design work on the DRZC will provide further insight on this requirement.

The frequency measuring devices should be under the control of the DNOs or integral part of the DRZC.

Table 17.3

Systems required for automated DNO control

System	Location	Current state/notes
Integrated Energy Management System (IEMS)	NGESO, TSO	This is currently in place.
Distribution Energy Management System (DMS)	DNOs	This is currently in place.
DRZ Controller	DNOs or NGESO	This will depend on the design specifications.
ICCP	Connecting NGESO IEMS and DNOs DMS	This is partially deployed. This will need to be deployed to all DNOs.
Frequency Measurement Devices	DNOs	This will be required to be deployed to all DNOs and incorporated as part of the micro-grid solution.

17.2.4 Manual DNO control

The manual DNO control model aligns mostly with the manual NGESO control model.

The ICCP link is still considered essential to provide visibility to NGESO during synchronisation to the transmission system. The DNOs will require frequency measuring devices located on their network to enable restoration of their network.

Table 17.4

Systems required for manual DNO control

System	Location	Current state/notes
Integrated Energy Management System (IEMS)	NGESO, TSO	This is currently in place.
Distribution Energy Management System (DMS)	DNOs	This is currently in place.
ICCP	Connecting NGESO IEMS and DNOs DMS	This is partially deployed. This will need to be deployed to all DNOs.
Frequency Measurement Devices	DNOs	This requires to be deployed to all DNOs.

17.3 Distributed ReStart Zone controller (DRZC)

As discussed earlier, the project will deliver a functional specification for a new DRZC. This system will reduce

the workforce burden of manual processes and take fast-acting control of network and energy resources to maintain power island stability across the Black Start stages. Figure 17.1 provides a hierarchy of control and displays the system integration needs of the DRZC and the DMS/EMS systems.

Figure 17.1

Indicative system hierarchy only, significant variations exist between manufacturer designs and not all solutions use all levels of controller

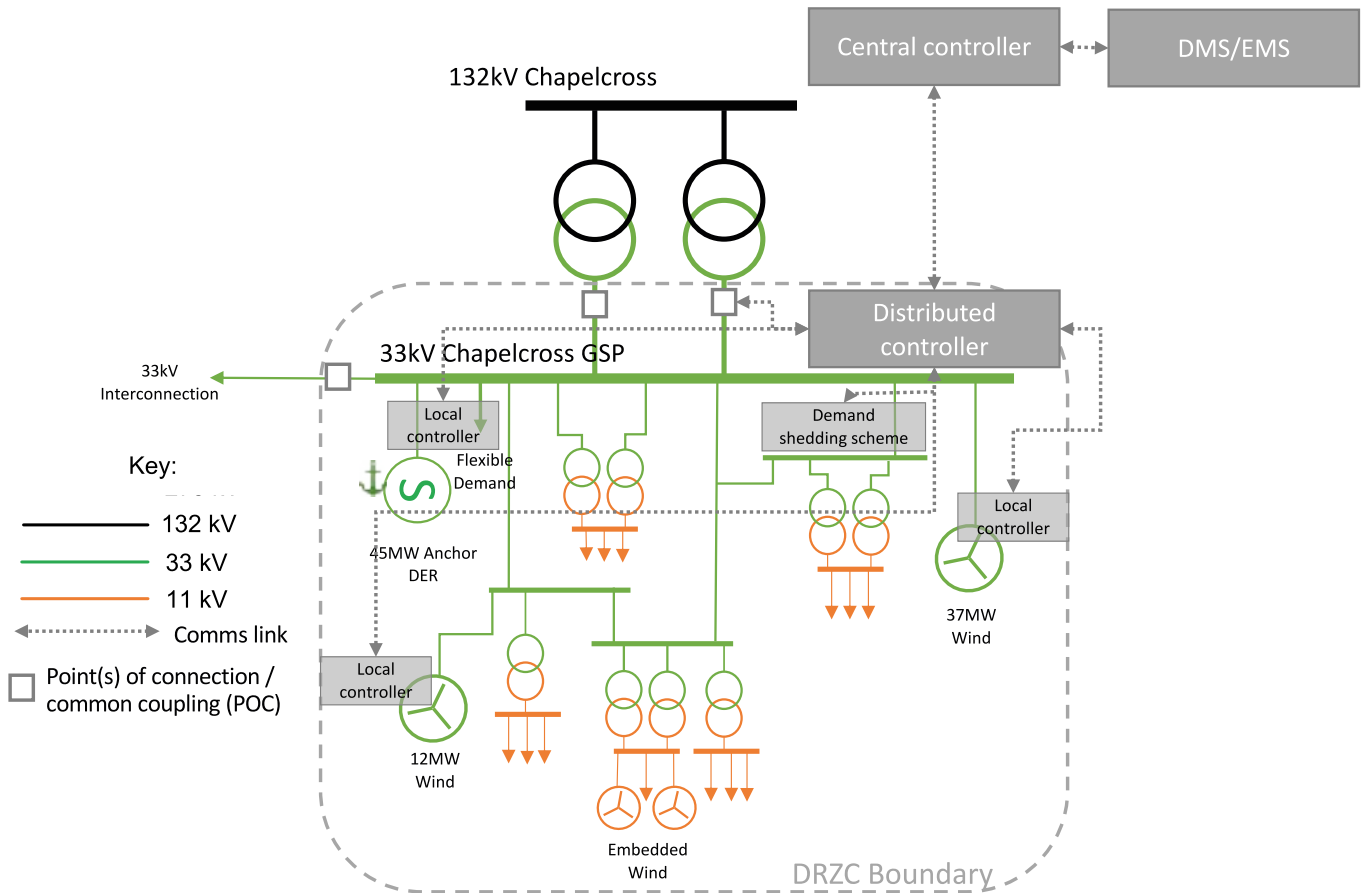

From a systems perspective, a key aspect of a DRZC is the interface between the central controller and the distribution management system or Energy Management System. Design variations result in a variety of approaches to this data exchange process. However, protocols such as ICCP have been recommended where a separate central controller and DMS are maintained. An alternative approach is to integrate the central controller function into the DMS system using only distributed controllers where fast calculated response actions are required.

Despite the potential for variations in DRZC design, there are common elements to all design solutions as detailed below. The DMS will:

- perform operator-initiated automated and manual switching actions
- manage voltage and power flows in the DRZ

- serve as the interface between the DRZC and certain resources that do not have a direct communications link to the DRZC – such as DERs (sending setpoints, and receiving present output and available power).

In addition, dependent upon DRZC design, the DMS may:

- serve as the interface for operators to monitor and issue instructions to DERs, including the anchor generator
- serve as the interface for supervision of the DRZC and activation, deactivation or suspension of DRZC balancing functions
- activate demand response on instruction from the DRZC (i.e. load shed).

Where this functionality is not provided directly through the DMS, a separate human machine interface (HMI) is required for the DRZC.

Regardless of any variation in DRZC design, a DRZC will:

- provide operators with visibility of DRZ behaviour during the restoration process, including confirmation of status, monitoring of frequency and voltage stability, and power island capability to resynchronise to the transmission system
- provide operators with a view of the current DRZC progress within the restoration plan
- display the response of connected energy and network resources
- actively control distribution network actions as described in section 9.

Dependent upon DRZC design, the DRZC may:

- provide real-time availability monitoring of the DRZC ahead of a Black Start event
- calculate and display the export capability of the power island at the point of connection.

All DRZC designs will make use of proprietary systems from manufacturers, with a functional specification developed to enable multiple manufacturers to create designs for future service roll-out. This functional specification will be used to drive system integration requirements in the refine stage of the project.

17.4 Next steps

The next steps will be to conduct a detailed analysis on the systems and applications required for the central model. The central model aligns closely with the automated DNO led model in terms of the physical control and management of assets. The completion of the DRZC design will feed into the detailed analysis of the systems and applications and may prompt a requirement for additional applications/systems or requirement for a new functionality. It is also suspected that further work on the DER control interface (discussed in section 19) may lead to a need for a new functionality which may lead to a new system or the use of a new functionality from an existing system.



DNO to DER interface requirements to deliver Black Start from DER are introduced in this section. These requirements will be presented in detail in OST design stage report II.

18.1 Introduction

The current control interface between the DNOs and DERs is designed for operating and managing the DNO network. The management of DERs for the purposes of Black Start is not a current consideration. During the design stage, OST is reviewing the current DNO to DER interfaces and the requirements to facilitate Distributed ReStart.

In this report we describe the existing interface, and our approach to assessing the needs for Distributed ReStart. The DNO to DER interface requirements to deliver Black Start from DER will be presented in design stage report II. The aim of the project is to develop options that support both manual and automated Black Start restoration.

18.2 Current DNO – DER control interface

At the current time, the control interface from the DNO to the DER control systems is limited to constraint management. For example, when a DER connects to the DNO network on the basis that the generation output will be reduced in real-time to mitigate DNO network constraints.

Such schemes typically 'control' the output from a DER by issuing setpoints to the DER site controller via a hardwired interface at the DER site between the DER site controller and the DNO remote terminal unit. The instruction is not ratified by the DER, the DNO simply monitors the DER's output for compliance. Should this not be forthcoming, the DNO remote terminal unit can disconnect the DER via the DNO site circuit breaker.

Figure 18.1
DNO – DER interface schematic

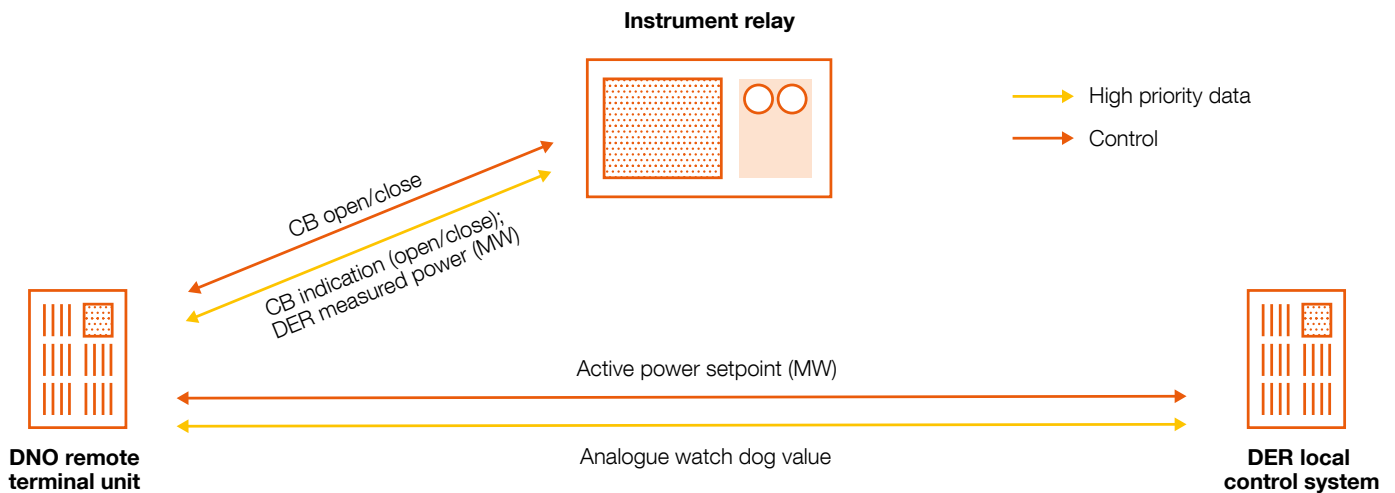

18.3 Approach to design stage

The current interface between the DNOs and DER for the management of the distribution network forms the basis of our analysis. Gap analysis will be carried out to identify what is required to restore the distribution system as it is (manual restoration) and the requirements of a DRZC. The outputs from this gap analysis will form part of the design stage report II.

18.4 General considerations

The requirement for control of the DER by the DRZC is a DER SCADA protocol-oriented connection between the DRZC and the DER controller. At present there is no analogous

interaction of systems between DNOs and DERs. The DER SCADA protocols vary i.e. there is no single standard implementation protocol. Hence the DRZC will be required to communicate via multiple protocols yet to be defined. This analysis is being undertaken as part of the DRZC design. We do not anticipate that the DRZC will be capable of complying with all possible DER SCADA protocols. The set of DER SCADA protocols against which the DRZC will need to be compliant will require definition.

18.5 Further work

The detailed investigation, gap analysis and design of the control interface will form the next stage of analysis. This work is being carried out by the OST and PET workstreams.



Central organisational model proposed; draft operational telecommunications functional specification to be delivered in design stage report II.

19.1 Introduction

The main conclusions and recommendations in this design stage report I centre around the organisation and process aspects of the OST work. These are summarised below. The next steps for the OST workstream focus on operational telecommunications and systems.

19.2 Organisation and process recommendations

19.2.1 Central model

Consultation to date has demonstrated a willingness and appetite for DNOs to take on an enhanced role within the restoration process. However, it has also demonstrated that national leadership from NGESO remains a key factor in the effectiveness of plan delivery. As a result of this ongoing feedback and efficiency analysis, OST proposes a collaborative organisational model, the central model.

19.2.2 Process design

In designing a Distributed ReStart process, OST has aimed to eliminate inefficiencies from the viability stage options. The creation of full process maps for both DNO and NGESO led procedures allowed OST to evaluate their overall efficiency in terms of execution time and staff requirements. In the central model, wherever possible, tasks have been allocated to the entity that was most qualified to undertake them.

Following further analysis and consultation on the four viability stage models, procedures have been refined to ensure that, as far as possible, actions are attributed to the existing capabilities of each entity. This has resulted in the responsibilities as shown in table 19.1.

Table 19.1

Table of responsibilities in the proposed collaborative organisational model

Action	Responsible control entity
Declare Black Start	NGESO
Responsible for national strategy	NGESO
Responsible for regional strategy	NGESO
Instruct start of plan	NGESO/Scottish TO
Instruct start of Anchor DER	DNO
Instruct transmission switching actions	NGESO
Physical transmission network actions	TO
Physical distribution network actions	DNO
Physical actions of contracted generation	Multiple individual providers
Instruct DRZ energisation route	DNO/Scottish TO
Instruct growth option outside of DRZ boundary	NGESO
Instruct DERs within a DRZ	DNO/Scottish TO
Instruct DERs outside of DRZ boundary	NGESO
Instruct non-contracted DERs (emergency instruction equivalent procedure)	NGESO via DNO instruction
Manage overall distribution power island voltage and frequency	DNO is frequency lead until synchronisation with an energy resource or demand outside of the DRZ

19.2.3 Organisational design

Considering the process and organisational analysis across this report we recommend the use of a DRZ controller. In the initial roll-out of Distributed ReStart, a controller offering a solution similar to an ANM scheme with regards to DER control is anticipated.

Such a controller will require distribution control engineer intervention but allow a single control engineer to manage a distribution level plan without inhibiting the existing Black Start process.

It is recommended that where the DRZC automation is not available, no more than one DRZ is instructed per DNO control room to prevent excessive distribution control engineer requirements. This still enables multiple plans to be enacted in parallel across GB due to the distribution of this responsibility across multiple organisations. To further assess the capabilities of a control engineer to manage multiple DRZ where a controller is implemented, a more mature design is required. This will be investigated through desktop exercises during the latter stages of the project.

19.3 Next steps (design stage report II and refine stage)

19.3.1 Organisation, process design and desktop exercises

During 2021, we will be delivering a number of desktop exercises to test Distributed ReStart process(es) in terms of the roles for each Black Start participant, and the timing of the process.

These will also allow us to increase stakeholder participation in Distributed ReStart to gain valuable feedback for process refinement; work through a range of scenarios; and gain information for development of high-level training plans.

The development of process maps has been iterative, with stakeholder comments, expectations or efficiency goals. The next stage of this project will be to test these procedures through use of desktop exercises and potential simulation of an event. This coupled with the learnings from live power engineering trials will provide confidence in the efficacy of Distributed ReStart should a Black Start event occur and provide the model for training and assurance of the ongoing service.

We anticipate significant value to be unlocked from desktop exercises with cross-industry participation. These exercises may be repeated multiple times and will look to test various Black Start scenarios. This will help ensure robust, fit for purpose processes that can adapt to different possible needs cases.

19.3.2 Refine processes and organisational structures

Ahead of issuing a final proposal, OST will seek to maximise the efficiency of the processes and organisational structures. In addition to the inputs and consultation discussed earlier, OST appreciates that a broader range of views may unlock further insights and more cost and time effective restoration plans. For this reason, the project will conduct a review from a business perspective through organisational design experts. This will follow a similar methodology to the review conducted on the existing Black Start process, enabling resource levelling to allocate roles within NGENSO.

19.3.3 Operational telecommunications

Functional specification

Development of the functional requirements and consultation continues with operational telecommunications suppliers and the existing consultees. OST believes that it is essential to avoid conflict with (and ideally complement) other initiatives. For that reason, the draft functional specification will form a central part of design stage report II later in 2020. Key information to be reviewed in the development of the functional specification includes:

- the DRZ controller outputs (due September 2020)
- outputs from the STG work on Operational Telecommunications Standard for Connected Distributed Generation and Storage (in early stages of drafting)
- the DER Cyber Security Connection Guidance (due to be published September 2020, consulted on in 2021).

Cost case studies

Design stage report II will also include the outputs (in terms of variations in costs and technologies) for the cost case study types.

Cyber security analysis

The threat landscape is evolving and could be subject to disruptive change. Distributed ReStart could be a potential target for highly capable threat sources looking to disrupt critical national infrastructure (CNI). The macro level trends we have identified in technology, digitalisation and accelerating cyber threats suggest that rapid and unforeseen changes in the cyber security landscape could occur between now and 2030.

Our risk assessment of the control and telecommunications options allows the likelihood and impact of potential threats and threat sources to be estimated. The level of risk associated with each option can be understood allowing lower risk options to be considered in more depth. The risk assessment considers the evolving threat landscape through to 2030 to ensure trends are appropriately considered.

The evolving cyber threat landscape and level of cyber security risk can be addressed for Distributed ReStart through a set of mitigations and controls. The candidate mitigations which have been identified cover the main areas of risk around the supply chain, 3rd parties, people, process and technology. All these mitigations will come with an associated cost and will result in a certain level of risk reduction (benefit).

Mitigations can be assessed using a cost/benefit analysis to achieve an acceptable level of residual risk which protects Distributed ReStart against a wide range of potential cyber attacks in a cost proportionate manner. The level of cyber threat and potentially rapid changes in the cyber security landscape mean that investing in cyber-resilience will be essential to protect Distributed ReStart.

Systems and DER interface

A detailed analysis of the systems and applications required for the central model will be conducted over the coming months. In terms of physical control and asset management, the central model aligns closely with the automated DNO led model which will form the basis of this work.

The completion of the DRZC design will feed into this work should further requirements from the DRZC design prompt a requirement for additional new applications/systems or requirement for a new functionality. Further work on the DER control interface (discussed in section 19) may also lead to a need for additional system functionality.

The detailed investigation, gap analysis and design of the control interface will form the next stage on analysis. This work is partly being carried out as part of the PET DRZC design.

19.4 Content summary for design stage report II

The design stage report II will centre around Distributed ReStart operational telecommunications and system requirements. A summary of the contents is outlined below.

- Draft functional specification
- Outputs from the OST cost case studies
- Further end-to-end cyber-resilience analysis
- Analysis of the systems' functionality considered essential to Distributed ReStart
- An introduction to the DER control interface
- Initial gap analysis of the current and required DER control interface.

19.5 Refine stage

Work will continue into 2021, with the detail of the central model being developed alongside the operational telecommunications functional specification. Distributed ReStart will also continue to assess the risk as the project evolves, ensuring a robust and resilient Distributed ReStart capability now and in the future.

Close collaboration across the project workstreams will be maintained to provide a coherent and complete set of proposals for Distributed ReStart. External engagement will be increased, specifically with trade organisations and DER, as we move into delivering desktop exercises and finalising our proposals.

Distributed ReStart



Appendices

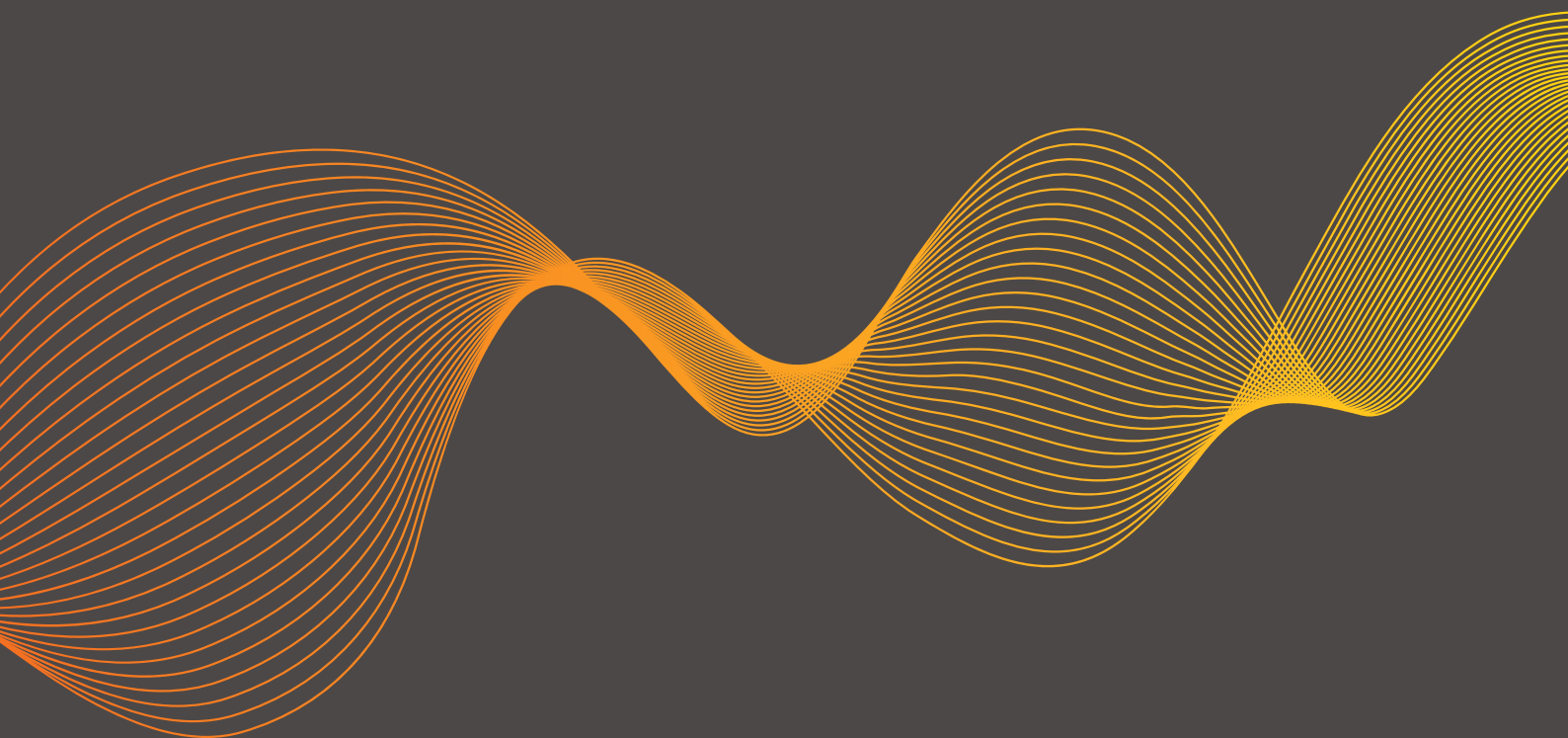



- [1] NGESO; Scottish Power Energy Networks; TNEI, "Power Engineering and Trials – Power Systems Studies Part 1" Distributed ReStart, 2020.
- [2] NGESO, "Operating Code 9," in Grid Code, 2020.
- [3] "Project Working Group membership," in Cigre Working Group C2.26.
- [4] S. d. Graaff, "Power system restoration – World practices and future trends," CIGRE Science and Engineering Journal, vol. 14, no. January, 2019.
- [5] J. Wang, L. Mu, Z. Fan and Z. Xin, "A Parallel Restoration for Black Start of Micro-grids Considering Characteristics of Distributed Generation," Energies, 2017.
- [6] Z. Xu, P. Yang, Q. Zheng and Z. Zeng, "Study on Black Start strategy of micro-grid and PV with multiple energy storage systems," in 18th International Conference on Electrical Machines and Systems, Pattaya, 2015.
- [7] NGESO; Scottish Power Energy Networks; TNEI, "Viability of restoration from DERs," NGESO, 2019.
- [8] NGESO; Scottish Power Energy Networks; TNEI, "The Viability of Organisational, Systems and Telecommunications," Distributed ReStart, 2019.
- [9] Open Networks, "2019 In Review," Energy Networks Association, December 2019.
- [10] Open Networks, "Open Networks DSO Implementation Plan," Energy Networks Association, July 2020.
- [11] National Grid Electricity System Operator, "Organisational, Systems and Telecommunications Viability report," NGESO, 2019.
- [12] Project consultations with BEAMA.
- [13] Project consultation with UK Cyber Security Task Group.
- [14] Global System for Mobile Telecommunication Association, Project Consultations with Global System for Mobile Telecommunication Association.
- [15] Europe Utility Technology Council, The connectivity challenge for future energy networks, 2020.
- [16] Cyber Security Consultations with Imperial College, Smart Power Networks.
- [17] SSEN, Costain, E.ON, Resilience as a Service NIC Project.
- [18] Project consultations with OFCOM.
- [19] Strategic Telecommunications Group, Project consultations with the ENA Strategic Telecommunications Group.
- [20] Project consultations with OFGEM.
- [21] Cyber Security and Infrastructure Agency, "ICS Joint Security Report Shamoon/DistTrack Malware," April 2017 [Available online]: <https://www.us-cert.gov/ics/jsar/JSAR-12-241-01B>
- [22] Cyber Security and Infrastructure Agency, "Alert, Crash Override Malware," July 2017, [Available online]: <https://us-cert.cisa.gov/ncas/alerts/TA17-163A>
- [23] The Energyst "Exelon hit by cyber attack," May 2020 [Available online]: <https://theenergyst.com/elexon-hit-by-cyber-attack/>
- [24] Smart Energy, "EDP hit by cyber attack," April 2020 [Available online]: <https://www.smart-energy.com/industry-sectors/cybersecurity/edp-hit-by-cyberattack-10-9-million-ransom-ordered/>
- [25] The Guardian "Cyber attack Australia: Sophisticated attacks from 'state-based actor'," Jun 2020, [Available online]: <https://www.theguardian.com/australia-news/2020/jun/19/australia-cyber-attack-attacks-hack-state-based-actor-says-australian-prime-minister-scott-morrison>

21. RAID log



ID	Risk description and impact	Deliverable impacted	Project or solution risk	Mitigation actions and contingency	Status
1	The eventual organisational and systems design restricts capability to a limited number of DNO areas. This could reduce project benefits.	OST	Project	Our design process includes extensive stakeholder engagement with DNOs across GB to ensure all DNOs are considered during all project phases. See assumption: ICCP links will be in place (based on engagement with DNOs).	Risk
2	Procurement time scales may be longer than expected. This could result in project delays.	PET, OST, Project Direction	Project	The procurement process for live trials began as early as possible. Participation Agreement drafted and nearly ready to be used for negotiations with trial participants. Opening discussions with National Grid Global Procurement to review overall procurement process.	Risk
3	Organisational, technical, procurement and regulatory proposals do not align. This could reduce project benefits.	All	Project	Design Architects are included in the project team to align outcomes across various workstreams. They attend regular workstream lead meetings to support the mitigation against this risk. This is based on learning from previous innovation projects. Design Assumptions log created and being refined.	Risk
4	Partner companies may not maintain/provide resource at planned levels. This could result in project delays.	All	Project	All partner companies have a nominated Project Management function to ensure internal resourcing remains at the required levels to meet deliverables.	Risk
5	Numbers of control engineers required due to complexity in power islands is not practical for existing relevant system operators	OST	Solution	This is an options risk, relevant to any options considered during the lifespan of the project. Central model proposed by OST seeks to minimise risk.	Risk
6	Roles and skillsets required for DER are challenging to resource	OST	Solution	Optioneering will determine the skillsets and will need to be managed carefully. Central model proposed by OST seeks to minimise risk. Desktop exercises will allow detailed requirements to be identified.	Risk
7	High cost of providing sufficient resilience in telecommunications means focusing on a small number of large resources, limiting involvement of smaller DERs	OST	Solution	Identified as a risk, will need careful managing during optioneering. Costs of meeting functional requirements will be illustrated in OST Design Phase report II.	Risk
8	Black Start Task Group – roll-out of Black Start resilience	OST	Project and solution	Roll-out of Black Start Standard is a dependency for telecommunications resilience requirements (PDM2) – working assumption agreement with Black Start BAU is 72hrs.	Risk
07	Cyber security	OST	Project	Key aspect of resilience across the full project – it is not mentioned specifically in the BID, this may incur additional cost and effort – scope creep. NGENSO global IS fully engaged.	Risk
10	DRZ controller – delivery timeline	PET and OST	Project	Delivery timelines reviewed, deliverables split into July and December – No material change to the overall project deliverable – COVID-19 needs to be monitored during the easing of lockdown	Risk

22. Terminology

Key term	Definition
Active network management (ANM)	Active network management (ANM) connects separate components of an electricity network such as smaller energy generators, renewable generation, storage devices, etc by implementing software to monitor and control the operation of these devices.
Air wave	A mobile communications company which is utilised by Great Britain's emergency services using a private mobile radio technology.
Anchor generator	A generator with the ability to establish an independent voltage source (grid forming capability).
BEIS	Government department for business, energy and industrial strategy.
Black Start	The procedure necessary for a recovery from a total or partial shutdown.
Bulk supply point (BSP)	A point of supply from a transmission system to a distribution system.
Communication infrastructure	This is the backbone of the communication system over which telecommunication services are operated like data and voice services.
Critical national infrastructure (CNI)	Those critical elements of infrastructure, the loss or compromise of which could result in major detrimental impact on the availability, integrity or delivery of essential services; significant impact on national security, national defence, or the functioning of the state.
CUSC	Connection and use of systems code.
Distributed Energy Resource (DER)	DERs are electricity-producing resources or controllable loads that are connected to a local distribution system or connected to a host facility within the local distribution system.
Distributed Energy Resources Management System (DERMS)	A platform which helps mostly distribution system operators (DSO) manage their grids that are mainly based on Distributed Energy Resources (DER).
Distributed ReStart Zone (DRZ)	Power island in the distribution network used for Black Start purposes.
Distributed ReStart Zone controller (DRZC)	A system that monitors and controls one or more DRZs.
Distribution Network Operator (DNO)	A company licensed to distribute electricity in the UK.
Distribution System Operator (DSO)	A future entity responsible for actively operating the distribution network. ENA are currently investigating various DSO 'Worlds' outlining the division of responsibility and which entity is most appropriate to fulfil this activity.
Electricity System Operator (ESO)	National Grid Electricity System Operator Limited (NO: 11014226) whose registered office is at 1-3 Strand, London, WC2N 5EH as the person whose Transmission Licence Section C of such Transmission Licence has been given effect.
Emergency instruction	An instruction issued in emergency circumstances, pursuant to BC2.9, to the control point of a user. In the case of such instructions applicable to a BM unit, it may require an action or response which is outside the dynamic parameters, QPN or other relevant data, and may include an instruction to trip a genset.
Ethernet	This is a set of standard technologies used for connecting networks together. These are used for carrying data and voice traffic.
E-UTRAN node B (eNB)	Also known as evolved node B (abbreviated as eNodeB or eNB), is a complex base station in LTE network that handles radio communications with multiple devices in the cell and carries out radio resource management and handover decisions.
Evolved packet core (EPC)	A framework for providing converged voice and data on a 4G long-term evolution (LTE) network.
Gold Command	Gold Command is the strategic response team which is concerned with corporate communications issues and governmental liaison.

Key term	Definition
Grid supply point	A grid supply point where either:- (i) (a) the network operator or non embedded customer had placed purchase contracts for all of its plant and apparatus at that grid supply point on or after 7 September 2018, and (b) All of the network operator's or non embedded customer's plant and apparatus at that grid supply point was first connected to the transmission system on or after 18 August 2019; or (ii) the network operator's or non embedded customer's plant and apparatus at a grid supply point is the subject of a substantial modification which is effective on or after 18 August 2019.
House load	Operation which ensures that a power station can continue to supply its in-house load in the event of system faults resulting in power generating modules being disconnected from the system and tripped onto their auxiliary supplies.
Human machine interface	A software application that presents information to an operator about the stage of a process.
Inter-control centre communications protocol (ICCP)	Also known as IEC 60870-6/TASE.2, is a set of international standards specified by utility organisations to provide data exchange over wide area networks (WANs) between utility control centres, utilities, power pools, regional control centres, and non-utility generators.
Internet of things	Interconnection via the internet of computing, mechanical, digital and everyday objects, enabling them to send and receive information.
Jitter	Variation in the delay of received packets.
Latency	This refers to the delay that takes place during communication over a network.
Load management system (LMS)	Load management systems also known as demand side response systems adjust/control electrical load rather than generation output to balance supply of electricity.
Local joint restoration plan (LJRP)	A plan produced under OC9.4.7.12 detailing the agreed method and procedure by which a genset at a Black Start station (possibly with other gensets at that Black Start station) will energise part of the total system and meet complementary blocks of local demand so as to form a power island. In Scotland, the plan may also: cover more than one Black Start station; include gensets other than those at a Black Start station and cover the creation of one or more power islands.
Long-term evolution (LTE)	Long-term evolution (LTE) is a standard for wireless broadband communication for mobile devices. This is based on the GSM/EDGE and UMTS/HSPA technologies and sometimes referred to as 4G LTE.
Main interconnected transmission system (MITS)	All 400kV and 275kV supergrid elements of the onshore Great Britain transmission systems, and in Scotland the onshore 132kV elements of the transmission system operated in parallel with the supergrid.
Multiprotocol label switching (MPLS)	A protocol-agnostic routing technique designed to speed up and shape traffic flows across enterprise wide area and service provider networks.
Network segregation	The process of isolating electricity networks to provide discrete power demand in 'blocks'.
Network slicing	This is a specific form of virtualisation that allows multiple logical networks to run on top of a shared physical network infrastructure. The different networks can then be built or designed to different specifications to meet different needs.
NIS directive	EU wide legislation on cyber security.
OFCOM	The office of communications – UK's communications regulator.
OFGEM	Office of gas and electricity markets, the government regulator for gas and electricity markets in GB.
OPTEL	National Grid Electricity Transmission operated power resilient fibre optic network.
Optical ground wire (OPGW)	An optical ground wire (also known as an OPGW or, in the IEEE standard, an optical fibre composite overhead ground wire) is a type of cable that is used in overhead power lines.
Optical phase conductor (OPPC)	An alternative telecommunications solution when there is no existing ground wire, meaning optical ground wire (OPGW) is not a viable option.
Passive optical network (PON)	A fibre-optic telecommunications technology for delivering broadband network access to end-customers. Passive optical networks are often referred to as the "last mile" between an internet service provider (ISP) and its customers.
Power island	A part of the electricity network that is electrically disconnected from the larger grid and operated in an islanded mode, usually during a partial or total power system shutdown.
P/Q setpoints	Real and reactive power targets for a generator to deliver.

Key term	Definition
Public switched telephone network (PSTN)	Circuit switched telephone network, providing infrastructure and services for public communication.
Remote terminal unit (RTU)	An electronic device that interfaces between physical assets and a control system.
RTDS	Real-time digital simulation of a power system.
Supervisory control and data acquisition (SCADA)	A computer system for gathering and analysing real-time data and used to remotely monitor and control equipment. Mostly used in telecommunication, utility, oil and gas industries.
Silver Command	The tactical response team which liaises between the operational command and control function, non-operational external parties and the Gold Command function.
Synchronous digital hierarchy	A standard technology for synchronous data transmission on optical media.
Technology readiness level (TRL)	A method for estimating the maturity and suitability of technologies.
Terrestrial trunked radio (TETRA)	An open digital radio standard for professional mobile radio. TETRA can be used by a company for communication within a private radio or commercial bases.
Transmission network owner (TO)	A company licensed to transmit electricity in the UK.
Transponder	An integrated wireless receiver and transmitter system used to transmit and/or receive radio signals.
Trunk	A communications link designed to carry multiple signals simultaneously to provide network access between two points. It interconnects switching nodes.
Very small aperture terminal (VSAT)	This refers to any two-way satellite ground mounted or a stabilised maritime VSAT antenna with an antenna (dish) that is smaller than three metres.
Voice over internet protocol (VOIP)	A means of voice communications.

National Grid System Operator

Faraday House
Warwick Technology Park
Gallows Hill
Warwick
CV34 6DA
United Kingdom

Registered in England and Wales
No. 11014226

www.nationalgrideso.com

nationalgridESO