

Draft Final CUSC Modification Report

CMP337 & CMP338

Impact of DNO Contributions on Actual Project Costs and Expansion Factors' & New Definition of Cost Adjustment

Overview:

To allow Distribution Network Operators to contribute to the cost of new transmission assets and allow this contribution to be netted off from the Transmission Owner's actual project costs. CMP338 introduces a new definition of "Cost Adjustment" to give effect to CMP337.

Modification process & timetable

1	<ul style="list-style-type: none"> • Proposal form • 16 January 2020
2	<ul style="list-style-type: none"> • Workgroup Consultation • 30 April 2020 - 11 May 2020
3	<ul style="list-style-type: none"> • Workgroup Report • 14 May 2020
4	<ul style="list-style-type: none"> • Code Administrator Consultation • 20 May 2020 - (2pm) 26 May 2020
5	<ul style="list-style-type: none"> • Draft Code Modification Report • 27 May 2020
6	<ul style="list-style-type: none"> • Final Code Modification Report • 2 June 2020
7	<ul style="list-style-type: none"> • Implementation • 1 April 2024

Have 5 minutes? Read our [Executive summary](#)

Have 20 minutes? Read the full [Draft Final Modification Report](#)

Have 30 minutes? Read the full Draft Final Modification Report and annexes

Status summary: Draft Final Modification Report. This Report will be submitted to the CUSC Panel for them to carry out their Recommendation Vote on whether these changes should happen.

<p>This modification is expected to have a: Medium impact</p>	Distribution Network Operators, Transmission Owners, Remote Island Generators (Shetland, Western Isles and Orkney)	
<p>Governance route</p>	This modification will be assessed by a Workgroup and Ofgem will make the decision on whether it should be implemented. On the 1 April 2020, the Authority approved that CMP337/CMP338 should be progressed as Urgent .	
<p>Who can I talk to about the change?</p>	<p>Proposer: Rachel Kettles, SHEP-D Rachel.Kettles@sse.com Phone: 01738 512023</p>	<p>Code Administrator Chair: Shazia Akhtar Shazia.Akhtar2@nationalgrideso.com Phone: 07787 266972</p>

Executive Summary

CMP337 intends to make minor and mechanistic changes to sections 14.15.75 and 14.15.76 of the CUSC in order to clarify and remove ambiguity associated with interpretation of the application of the contributions in relation to “actual project costs”. These have already been agreed in principle by the Authority as reflecting the policy intent of its decision.

The changes will make clear that a Distribution Network Operator (DNO) contribution would be applied to reduce the total costs of the new transmission asset to the Transmission Owner (TO), and would be netted off from the TO’s “actual project costs” in a way which changes no aspect of transmission charging and maintains the exact pro-rating of costs between local and wider TNUoS charge elements, as is currently in place.

CMP338 seeks to implement that decision through the addition of the definition of the contribution from a DNO as a “Cost Adjustment”.

What is the issue?

“Actual project costs” at 14.15.75, used to calculate AC subsea cable and HVDC circuit expansion factors, is undefined. It is ambiguous whether it may be a value net of a DNO contribution.

What is the solution and when will it come into effect?

Proposers solution:

The Proposer seeks to:

Add reference to DNO contribution (“Cost Adjustment”) to 14.15.75 - to clarify that “actual project costs” may be a value from which a contribution has been netted off, and;

Add clarification to 14.15.76 - the pro-rating of costs under prevailing methodology is same whether a contribution has or has not been applied – to clarify no change to pro-rating.

Potential solutions:

The Workgroup reviewed analysis, to confirm that the contribution affects TNUoS charges in these new charging scenarios in a transparent and non-distortive way.

Three charging scenarios for consideration:

- Local circuit recovery
- Zone 1 Wider TNUoS recovery
- New Shetland Zone Wider TNUoS recovery

Implementation date:

A decision on CMP337 and CMP338 is needed in June 2020. The modifications must be in effect by 1 April of TNUoS charging year 2024, which is expected to be the point at which the Shetland link is made available to users.

Summary of potential alternative solution(s) and implementation date(s):

No alternatives were raised as part of the Workgroup process.

Workgroup conclusions

The Workgroup unanimously agreed that both CMP337 and CMP338 better facilitate the applicable CUSC objectives and should be implemented.

What is the impact if this change is made?**Who will it impact?**

These modifications may have an impact on specific Distribution Network Operators, Transmission Owners, Remote Island Generators (Shetland, Western Isles and Orkney) if and to the extent that the Authority approves a DNO contribution. Depending on the classification of the node on the relevant island (Main Integrated Transmission System MITS or local) there may be an impact on the TNUoS Generator Residual tariff. Depending also on this classification there will be a counter and corresponding impact on the Transmission Demand Residual and therefore Demand customers.

Interactions

The Workgroup acknowledged the overlap with [CMP303](#) 'Improving Local Circuit Charge Cost – Reflectivity' and [CMP320](#) 'Island MITs Radial Link Security Factor' which are with the Authority for a decision. The Workgroup agreed that although CMP337/CMP338 seeks to amend the same Sections of the CUSC as CMP303, there is no direct impact. The Workgroup agreed that if all the modifications were approved by the Authority, then the Code Administrator may need to raise a housekeeping modification to ensure the legal text is consistent with what has been approved.

Introduction

This document is the CMP337 & CMP338 **Draft Final Modification Report**. This document outlines;

- **What is the issue?**
- **What is the solution?**
 - Proposer's solution
 - Workgroup considerations and consultation summary
 - Alternative solutions
 - Final legal text
- **What is the impact of this change?**
 - Workgroup vote
 - Code Administrator Consultation Summary
- **When will the change take place?**
- **Acronym table and reference material**
- **Annexes**

What is the issue?

What is the issue?

In its [decision](#) of 17 December 2019 the Authority approved the principle of a licensed DNO making a contribution to a licensed TO, which recognises the value to the DNO (and its customers) of a new transmission asset provided by that TO. Under this arrangement, the total cost of the transmission asset is not affected, but the cost is split between the customers of the relevant DNO and the TO (TNUoS) as users of the asset, according to the value that the asset brings to the DNO as a user of the asset, approved separately by the Authority.

The CUSC modification proposed by SHEPD, already agreed in principle by the Authority as set out in its decision, is required to only to make it clear that “actual project costs” may be a value net of a contribution, and to ensure that there is no impact upon the existing pro-rating of costs across local and wider TNUoS charge elements.

Why is it an issue?

The CUSC is ambiguous as to whether it recognises that “actual project costs” may be a value from which a DNO contribution has been netted off, to reflect the fact that distribution customers are making a contribution with the effect of sharing cost between two licensees as determined separately by the Authority. This contribution or “Cost Adjustment” would have the effect that customers paying TNUoS pay for the net cost of the asset. The modification seeks to provide clarity and certainty that the “actual project costs” value would, where a contribution has been approved by the Authority, be a net cost value. As the CUSC does not currently include the term or definition of “Cost Adjustment”, this is addressed in CMP338.

What is the solution?

Proposer's solution:

- Add reference to DNO contribution (“Cost Adjustment”) to 14.15.75 - to clarify that “actual project costs” may be a value from which a contribution has been netted off, and;
- Add clarification to 14.15.76 - the pro-rating of costs under prevailing methodology is same whether a contribution has or has not been applied – to clarify no change to existing pro-rating between cable/converter asset costs and “other” costs of the link for the purpose of calculating expansion factors.

Workgroup Considerations

The Workgroup convened four times to discuss the perceived issue, detail the scope of the proposed defect, devise potential solutions and assess the proposal in terms of the Applicable CUSC Objectives.

Potential options

The Workgroup discussed the effect of the contribution on MITs Node Charging scenarios to ensure it was transparent and non-distortive. The Workgroup looked at three different Charging scenarios

- Local Circuit Recovery
- Zone 1 Wider TNUoS recovery &
- New Zone for Shetland – wider TNUoS recovery

For the purposes of the following analysis a scenario was created using the Shetland Link project as an example. The asset costs (those of cable and converters and associated proportion of scheme overheads) were assumed to be £504million. This figure is the latest information as provided by SHET to the ESO for production of the 5-year forecast. The total cost of the link was assumed to be £700million.

The assumed contribution was £200million. As the contribution is applied to the total link cost, this was pro rata'ed between the asset costs which are used to build circuit specific expansion factors and the “other” costs which form part of the TO MAR and are recovered from the Transmission Demand Residual pot according to the prevailing TNUoS methodology. For more detail please visit the assumptions tab of the associated workbook.

Net link costs

As the proposed link is an HVDC link, actual project costs, relating to specific named assets, are used to calculate the circuit expansion factors for the purposes of TNUoS charging. The Proposer’s modifications set out that the contribution is captured for purpose of TNUoS charging within the link costs at CUSC 14.15.75/76 and is targeted at connecting generators simply via a net link cost value. The Proposer intends, and is of the view, that this modification will not change the TNUoS methodology. The modification will clarify that for the purposes of calculating expansion factors for HVDC and sub-sea AC links the actual project costs used in the calculation may be net of a third-party capital contribution, and that the contribution takes effect via a net link cost value. This assumption is the same for each of the TNUoS charging scenarios.

By way of illustration, if a link costs £Xm and the contribution is £Ym, then the net link cost is £Zm. Under all scenarios, the modification is intended to replicate the effects on TNUoS charging should the link cost £Zm without any contribution.

Scenario 1 - Local Circuit Recovery

NGESO provided the Workgroup with a working scenario for Local Circuit TNUoS tariffs for Charging Year 2024/25, showing the impact of a third-party capital contribution flowing through the TNUoS methodology via a net link cost value of £500m. The Workgroup considered the Local Circuit Recovery of the link costs. The workgroup agreed that the contribution effect would be transparent and non-distortive. A reduction in link costs (as a result of a third-party capital contribution or otherwise) carries through the methodology to the relevant local circuit tariffs and non-local circuit TNUoS charges (which are recovered through the Transmission Demand Residual (TDR)). The contribution does not affect the baseline charging methodology, and the numerical effects are the same where a link cost is, per the assumptions used by the workgroup, £500m net of a contribution, or £500m where no contribution has been applied.

Local Circuit Tariff (without contribution)	Local Circuit Tariff (with contribution)	Delta
£74.12/kW	£52.94/kW	-£21.18/kW

Generation - Wider Tariff Elements						
Zone No.	Zone Name	Scenario	Peak Security (£/kW)	Year Round Shared (£/kW)	Year Round Not Shared (£/kW)	Residual (£/kW)
1	North Scotland	Scenario 1 (with contribution)	1.946827	19.748612	26.103416	-9.912084
1	North Scotland	Scenario 1 (no contribution)	1.946827	19.748612	26.103416	-9.912084
Delta		Scenario 1	0.00	0.00	0.00	0.00

Revenue collection with a “Cost Adjustment”

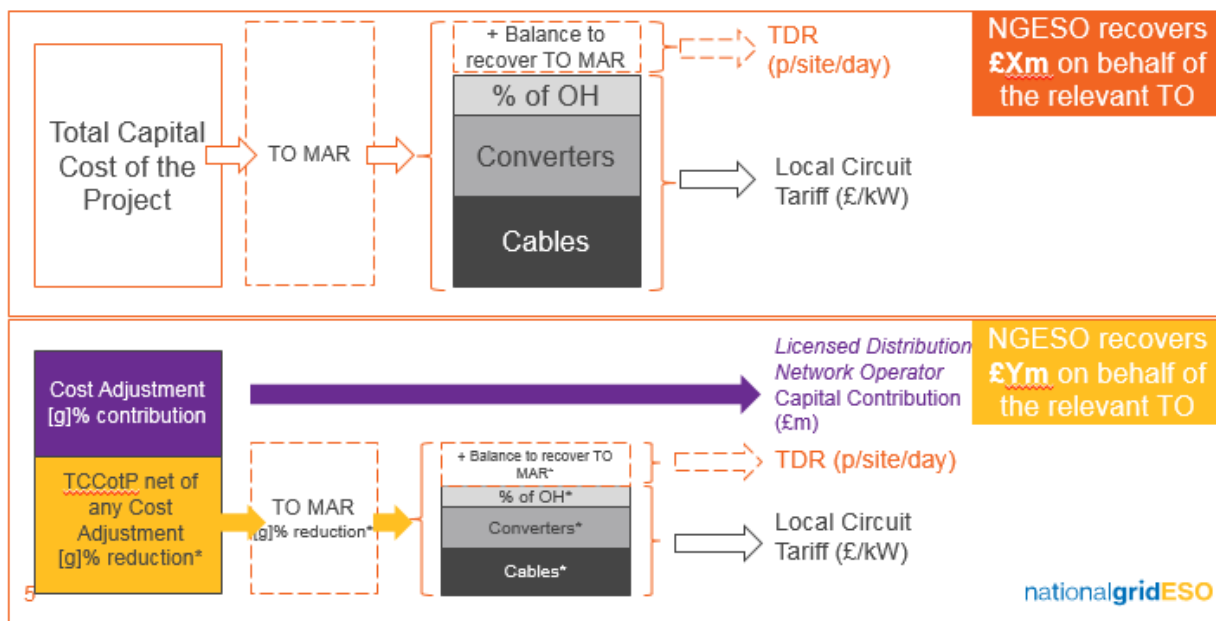

Scenario 2 - Zone 1 Wider TNUoS recovery

NGESO provided the Workgroup with a working scenario for Zone 1 wider TNUoS tariffs for Charging Year 2024/25, showing the impact of a third-party capital contribution flowing through the TNUoS methodology via a net link cost value of £500m. This was using a Security Factor of 1.8 which is the default assumption for all wider circuits in the DCLF ICRP model. The Workgroup questioned if this could be demonstrated using a Security Factor of 1.0, on the assumption that CMP320¹ would be approved.

Generation - Wider Tariff Elements			Peak Security (£/kW)	Year Round Shared (£/kW)	Year Round Not Shared (£/kW)	Residual (£/kW)
Zone No.	Zone Name	Scenario				
1	North Scotland	Scenario 2 (with contribution)	1.946827	25.384370	32.187255	-9.660973
1	North Scotland	Scenario 2 (no contribution)	1.946827	26.810398	33.726662	-9.760031
Delta		Scenario 2	0.00	-1.43	-1.54	0.10

The Workgroup reviewed the calculations provided by the ESO, which shows the wider tariffs in Zone 1, with and without the contribution. The impact of the contribution using

¹ <https://www.nationalgrideso.com/codes/connection-and-use-system-code-cusc/modifications/island-mits-radial-link-security-factor>

the agreed assumptions is to reduce the Year Round Shared and Not Shared elements of the wider tariff for Zone 1 generators.

The contribution results in cheaper locational charges, which as a result reduces the amount paid by Zone 1 generators through wider TNUoS. There are distributional effects as a result of the 838/2010 Limiting Regulation and the overall reductions in the Zone 1 wider tariffs are matched by an overall increase in the Generator Residual tariff.

In terms of the impact on demand customers, the AAHEDC tariff is recovered on a volumetric basis whereas from April 2022 the TDR will be a fixed £/site/day charge for each of the different charging bands, but broadly AAHEDC payers can be considered the same group as TDR payers. This means those who fund the contribution through the AAHEDC tariff get it all back through the Transmission Demand Residual in this scenario.

The main cost of the contribution, in this scenario, as it works through the TNUoS methodology is on GB Transmission connected generators outside of Zone 1 who see their Residual Credit made “less negative” as a direct result of the lower link cost resulting from the third party capital contribution driven by the 838/2010 Limiting Regulation.

The Workgroup discussed how the net impact on generator residual is likely to be affected by the outcome of CUSC Modifications [CMP317/CMP327](#) ‘Removing Generator Residual and excluding assets required for connection’ and [CMP324/CMP325](#) ‘Generation Zones – changes for RIIO-T2 & re-zoning CMP324 expansion’. In particular, the result of CMP317/CMP327 may affect whether or not the cost of an island link local circuit charge is included in the calculation for compliance with regulation 838/2010, so whether a change in local circuit cost would result in a change to the generation residual. The outcome of CMP324/CMP325 may change the definition of generation charging zones, including Zone 1, which could change the scale of the generation charging base affected by changes to the wider tariff. The workgroup agreed that despite these interactions regarding the net impact on the generation residual, the implementation of these modifications are not contingent on each other.

The workgroup agreed that the contribution effect in scenario 2 would be transparent and non-distortive. The ESO agrees that this modification in itself does not change the TNUoS methodology and therefore must be equally as transparent and non-distortive as the baseline methodology. The ESO, is however, concerned that there are unintended distributive effects in this scenario (scenario 2) only. These effects are related to the actions of the TNUoS Generator Residual which increases as a direct counter to the reduction in Zone 1 tariffs. This means that some absolute benefits of the contribution specifically related to the asset components, the cables and converters, are received by demand TNUoS payers through the TDR which may be unintended.

A reduction in link costs (as a result of a third-party capital contribution or otherwise) carries through the methodology to the wider tariff elements for Zone 1 and, results in the wider locational tariffs being more cost reflective than baseline. The contribution does not change the baseline charging methodology, and the numerical effects on each tariff element are exactly the same where a link cost is, per the assumptions used by the workgroup, £500m net of a contribution, or £500m where no contribution has been applied.

Scenario 3 - New Zone for Shetland – wider TNUoS recovery

NGESO provided the Workgroup with a working scenario for a New Zone for Shetland - wider TNUoS tariffs for Charging Year 2024/25, showing the impact of a third-party capital contribution flowing through the TNUoS methodology via a net link cost value of £500m.

Generation - Wider Tariff Elements						
Zone No.	Zone Name	Scenario	Peak Security (£/kW)	Year Round Shared (£/kW)	Year Round Not Shared (£/kW)	Residual (£/kW)
0	Shetland	Scenario 3 (with contribution)	1.946827	0.000000	114.733163	-9.149113
0	Shetland	Scenario 3 (no contribution)	1.946827	0.000000	136.879649	-9.156806
Delta		Scenario 3	0.00	0.00	-22.15	0.01

The third cost recovery scenario shows the creation of a new Shetland Zone with bespoke wider tariffs. NGESO thought this would be a likely scenario, if a MITS node was on Shetland, as there is stipulation in the CUSC to undergo an “out of price control” rezoning exercise where the nodal price difference to be greater than +/-£1.

The impact of the contribution using the agreed assumptions is to reduce the YRNS wider tariff for the Shetland Zone.

In this scenario there is only a small effect on the generator residual. In fact, the total benefit for Shetland Developers using these contribution assumptions is much greater than the impact on the residual. This means in this scenario there are almost negligible distributional effects between generator groups and the benefit is received in a reduction of the Shetland developers’ TNUoS bills.

The workgroup agreed that the contribution effect in scenario 3 would be transparent and non-distortive. A reduction in link costs (as a result of a third-party capital contribution or otherwise) carries through the methodology to the wider tariff elements and, results in the wider locational tariffs being more cost reflective than baseline. as in the other scenarios, the contribution does not affect the baseline charging methodology, and the numerical effects on each tariff element are exactly the same where a link cost is, per the assumptions used by the workgroup, £500m net of a contribution, or £500m where no contribution has been applied.

Funding for a Solution for Shetland

Typically, DNO revenue is recovered from customers connected in that DNO area, whether they be generators or demand load. Any contributions approved by the Authority towards the Orkney or Western Isles would be recovered via SHEPD North of Scotland DUoS payees.

The [BEIS decision](#), published on 13 February 2020, which came into force further to parliamentary approval on 5 March, concluded that Shetland energy solution costs should be added to the amount recovered through the existing Hydro Benefit Replacement Scheme (also known as ‘Assistance for Areas with High Distribution Costs’ or AAHEDC), which it consulted on as part of its three-yearly review of the Hydro Benefit Replacement Scheme and the Common Tariff Obligation from July to September 2019. The AAHEDC scheme exists to support areas with high distribution costs and prevent customers located there paying costs which are much higher than any similar customers in the rest of GB. At present the AAHEDC scheme applies only to the North of Scotland.

The decision means that approved Shetland energy solution costs will be recovered from all GB suppliers / consumers via the AAHEDC mechanism from April 2021, instead of being funded by North of Scotland suppliers / consumers, which has been the arrangement to date. The amount included for Shetland energy solution costs from 2021 is £27m.

If a contribution towards the transmission link is approved, the scale of the contribution costs recovered via the AAHEDC would be the same and unaffected by any of the TNUoS charging scenarios being considered by CMP 337/8 – indicatively £251m (recovered over extended timeframe). The transmission-based solution is expected to drive a reduction in SHEPD revenue recovery via the AAHEDC (compared to other Solutions for Shetland) from the 2021 value.

SHEPD’s recommendation to Ofgem sets out that the transmission link-based solution for Shetland offers significant savings (indicatively £140m) compared to the best alternatives identified. If the transmission link-based solution doesn’t progress, a market solution is likely to be required, and the amount to be recovered through AAHEDC can be expected to be higher than the amount associated with the contribution.

The workgroup developed a suite of tables, see Annex 4, that summarised the impacts on different parties between the three scenarios. The purpose of the tables is to help set out the cost impact on different stakeholders in each scenario.

Orkney and Western Isles TNUoS effects

SHEPD has made recommendations to the Authority on contributions towards the Shetland, Orkney and Western Isles transmission links. Proposed CUSC modifications 337 and 338 are intended and expected to be effective for each of these island link proposals, and it is expected that the conclusions of the effects of the contributions upon TNUoS methodology to be exactly the same in principle as for Shetland (though SHEPD has confirmed that the contribution amounts, and absolute effect on TNUoS values, are expected to be different). The Authority set out in its December 2019 decision on SHEPD’s contribution proposals that it expects to separately consult on the proposed Western Isles and Orkney contributions in 2020. SHEPD is supporting this process. It can be expected that confirmation of the absolute effects of the Western Isles and Orkney contributions upon developer TNUoS would follow any positive Authority decisions on these contributions, as was the case with the Shetland process.

Workgroup Consultation summary

The Workgroup Consultation was carried out from 30 April 2020 – 11 May 2020 and seven responses were received. The Workgroup considered the responses. The full responses can be found in Annex 6.

The questions below were asked as part of the Workgroup consultation:

CMP337 - Standard Workgroup Consultation questions

1	Do you believe that the CMP337 Original Proposal better facilitates the Applicable CUSC Charging Objectives?	<p>Yes – 6 respondents</p> <p>Competition: This proposal enables efficient building and operating of the UK grid going forward. It also aids competition by allowing on generation in areas of very high use of system charges, which otherwise may not be connected.</p> <p>Cost reflectivity: CMP337/338 will provide greater clarity on Transmission Licensees' actual project costs by removing ambiguity, thereby making resulting TNUoS charges to generators more cost reflective.</p> <p>Developments in transmission licensees' transmission businesses: CMP337/338 takes a better account of the developments in transmission licensees' transmission businesses, because it implements the Authority's 17 December 2019 decision to approve a contribution by a DNO towards the costs of a transmission licensee's project.</p> <p>Compliance with the Electricity Regulation: These modifications are consistent with the intentions of the EU Renewable Energy Directive (2009/28/EC), which according to the European Union (Withdrawal) Act 2018, will continue to apply post-Brexit, and states: <i>"7. Member States shall ensure that the charging of transmission and distribution tariffs does not discriminate against electricity from renewable energy sources, including in particular electricity from renewable energy sources produced in peripheral regions, such as island regions, and in regions of low population density."</i></p> <p>Promotes efficiency in the implementation/administration of the CUSC: By efficiently enacting the Authority's 17 December 2019 decision. This will remove ambiguity in the interpretation of 14.15.75 and 14.15.76 of the CUSC with specific regard to the impact of DNO contributions on a transmission licensee's "actual project costs", avoiding</p>
---	--	--

		<p>future requirements for the CUSC administrative process to revisit this question.</p> <p>No – 1 respondent</p> <ul style="list-style-type: none"> • It does not better facilitate objectives a and b because it frustrates competition and reduces cost reflectivity. • It would distort the marginal cost of investing in the network in this area. Given that the point of the locational charge is to signal this cost so that generators make the correct investment decisions, then it should be fully reflected.
2	Do you support the proposed implementation approach for CMP337?	<p>Yes – 7 respondents</p> <ul style="list-style-type: none"> • CMP337 provides an effective and efficient way to enact the Authority's 17 December 2019 decision, in a way which maintains the existing pro-rating of costs between local and wider charge elements.
3	Do you have any other comments?	<p>4 respondents had other comments:</p> <ul style="list-style-type: none"> • A decision is needed by June 2020. • Charging scenarios: Scenario 1) a 'local circuit' TNUoS charge. The link related charges are reduced by the same % as the contribution/total link costs, the contribution costs are recovered fully via AAHEDC and there is no impact on the residual. This shows the rationale for the approach to implementing the DNO contribution is fully compatible with scenario 1. <p>Scenario 2) a wider TNUoS charge as part of zone 1 This appears to have material unintended consequences, in absolute terms it reduces costs in zone 1 by significantly less than the other scenarios, it also effectively recovers all of those costs (and more) from an offsetting increase in the residual for other generators, and not from a subset of demand via AAHEDC as is intended. The current proposed methodology for implementing a contribution is not compatible with this charging scenario.</p> <p>Scenario 3) and wider TNUoS charges with Shetland as a separate zone. For scenario 3 a 'Shetland only TNUoS zone' would have its charges reduced by an approximately similar absolute amount as scenario 1 but there is a small impact on the residual. It is not clear however, if this effect would always be immaterial for the Shetland example modelled, or if the impact could be</p>

		<p>more significant for contributions made in other future projects. The approach to implementing DNO contribution is compatible with this scenario, but it does not work as well as Scenario 1.</p> <p>We believe this analysis strengthens the case that local circuit charging is the most suited charging methodology for Remote Island generation TNUoS. The possibility of a MITs node being created on a Remote Island can be removed by the slight amendment to MITs definition, as set out in CMP320 (Island MITS Radial Link Security Factor) WACM 1.</p> <p>We do not think scenario 2 is cost reflective as it would result in other generators in TNUoS zone 1, subsidising the Island generators, it would breach section 14.15.42 which states nodes within zones should be within +/- £1/KW, although we understand why it has been included given the potential outcomes of <i>CMP324 & CMP325 (Generation Zones – changes for RIIO-T2' & 'Rezoning)</i>.</p> <p>Similarly, if the Remote Islands do become part of the MITs, and are charged via the wider methodology, it is important they form <i>separate</i> zones from each other. If for example they were grouped together as a single 'Remote Islands' zone, the underlying logic of the contribution methodology suggested by SHEPD that this CMP seeks to implement would unravel. A contribution to one link, would cross subsidise another which may not have the necessary benefits to consumers that supported the approval of contribution by the Authority in the first instance.</p> <ul style="list-style-type: none"> • The Shetland case is used as a particular example in the WG report. It is assumed that savings in DNO assets and longer term operational costs could be treated the same way for other Island Groups. • We generally support the modification as it stands but request that renewal of an existing 33kV sub-sea cable to Orkney, which is due within a similar timeframe to the new transmission link, is considered in a similar way to the Shetland model described in the Workgroup consultation.
4	Do you wish to raise a Workgroup Consultation Alternative Request	No – 7 respondents

	for the Workgroup to consider?	
CMP338 – Standard Workgroup Consultation questions		
1	Do you believe that the CMP338 Original Proposal better facilitates the Applicable CUSC Objectives?	<p>Yes – 6 respondents</p> <ul style="list-style-type: none"> • For the reasons already set out in CMP337 above. • We agree that the contribution from a DNO to a TO is best described as a “Cost Adjustment” and that it clarifies the definition of “Actual Project Costs” where DNO contributions is reflected in Generator TNUoS. <p>No – 1 respondent</p> <ul style="list-style-type: none"> • For the reasons already set out in CMP337 above.
2	Do you support the proposed implementation approach for CMP338?	<p>Yes – 7 respondents</p> <ul style="list-style-type: none"> • CMP338 is an efficient mechanism to facilitate the effective delivery and implementation of CMP337.
3	Do you have any other comments?	<p>1 respondent had other comments (in addition to the comments made under CMP337):</p> <ul style="list-style-type: none"> • The definition of “Cost Adjustment” should be tightened up to reflect the intention of the modification. • It should explicitly refer to “Transmission infrastructure investment” rather than just “infrastructure investment”. The modification has been raised to cover a very specific context where Remote Island links will effectively be cross-subsidised by GB consumers through the AAHEDC tariff, via payments made by SHEPD to SHETL. We are not aware of any non-transmission infrastructure being subsidised in this manner. • The words “a different Licensed Distribution Network Operator or” should be removed from the definition. As it has not been explained why this arrangement would cover a Distribution Network Operator’s costs or why these would be recovered through TNUoS. • The legal text is also light on the process that would be undertaken to ascertain the level of “Cost Adjustment”. We believe there should be an industry consultation to

		<p>ensure full transparency of the process. Similarly, the CUSC should specify that any agreed level will be reported in National Grid ESO's annual charging statement, particularly as it is being subsidised by GB consumers.</p> <ul style="list-style-type: none"> • Additional thought required on how subsequent additional infrastructure connecting the mainland to a Remote Island would be handled. For instance, if a "first phase" link is subsidised to 20% of the total cost, it does not necessarily mean that a second phase would be subsidised to the same extent or even at all. How would the methodology deal with this?
4	Do you wish to raise a Workgroup Consultation Alternative Request for the Workgroup to consider?	No – 7 respondents

The Workgroup considered the further comments received and concluded the below:

Comment: *Additional thought required on how subsequent additional infrastructure connecting the mainland to a Remote Island would be handled. For instance, if a "first phase" link is subsidised to 20% of the total cost, it does not necessarily mean that a second phase would be subsidised to the same extent or even at all. How would the methodology deal with this?*

Response: It is the workgroup's understanding that the TNUoS methodology would deal with link costs and translate these into TNUoS charges on a link-by-link basis, further to the requirements of CUSC Section 14. If there was a second phase link proposed, the second phase link costs would be subject to a discrete needs case and assessment of costs proposed by the relevant TO, and an assessment of benefits to the relevant distribution system by the DNO. Determinations on the need, cost and whether any cost adjustment should be applied would be made by the Authority. Any resulting cost, whether net of a contribution or not, would be applied within TNUoS methodology as a new and discrete value, determined separately by the Authority.

Comment: *The legal text is also light on the process that would be undertaken to ascertain the level of "Cost Adjustment". We believe there should be an industry consultation to ensure full transparency of the process. Similarly, the CUSC should specify that any agreed level will be reported in National Grid ESO's annual charging statement, particularly as it is being subsidised by GB consumers.*

Response: The level of a “Cost Adjustment”, or contribution, would be recommended by a DNO and determined upon by the Authority outside of CUSC processes and following consultation. The impact of a contribution on DNO and TO revenue would be confirmed through price control processes and mechanisms. SHEPD confirmed to the Panel that there are a number of public consultations already undertaken and which would be progressed in due course if the proposals progress which capture the level of the Shetland “Cost Adjustment” and the process by which its value is defined and implemented, which mean that there is a good level of industry and public consultation already in place in relation to the proposals. These include:

- The Authority’s consultation on SHEPD’s contribution recommendation (2019), which consulted on the contribution methodology, the specific proposed contribution amount for Shetland, and set out how the contribution value would be finalised before the contribution is made;
- The CUSC modification process for proposed modifications 337 and 338;

The Authority would also consult and follow similar processes for any other DNO contribution proposals towards other transmission link assets.

Separately, but related, BEIS consulted on the proposal to include the “Shetland assistance amount” to the AAHEDC amount and mechanism during 2019 and published a decision on this in 2020. The AAHEDC is subject to a three-yearly review and consultation – while the mechanism is agnostic to the specific Shetland supply solution, it can be expected that the next review would reflect on the contribution impact on the Shetland assistance amount, if approved.

The Workgroup does not believe that the annual ESO Charging Statement is the right place to include an Ofgem approved Cost Adjustment figure. The value will be available on the Ofgem website following due consultation for any interested parties to view. As the ESO we won’t be applying the contribution ourselves but rather the capital costs shared with us by the relevant Transmission Owner will be net of the approved Ofgem contribution value pro rata ed as intended in the legal text. Therefore, we do not feel it is appropriate to include this information in our charging statement as we wouldn’t normally publish transmission infrastructure asset costs used to calculate TNUoS tariffs.

Comment: *Scenario 2 - This appears to have material unintended consequences, in absolute terms it reduces costs in zone 1 by significantly less than the other scenarios, it also effectively recovers all of those costs (and more) from an offsetting increase in the residual for other generators, and not from a subset of demand via AAHEDC as is intended. The current proposed methodology for implementing a contribution is not compatible with this charging scenario.*

Response: The graphic below, demonstrates the principle that the residual is sensitive to the total being recovered through TNUoS charges.

If there are no costs associated to a link at all (a transmission link is not built) then the Generation Residual Tariff will be less negative than in both situations where a link is built.

This is because the Shetland generator TEC would not exist and therefore is not paying TNUoS. Additionally, the Zone 1 wider tariffs would be lower in the No Link example as the tariff doesn't include link costs. This, therefore, means the Generation Residual would be less negative, all else being equal.

Scenario 2 (Zone 1 Recovery) – Generation Residual Tariff

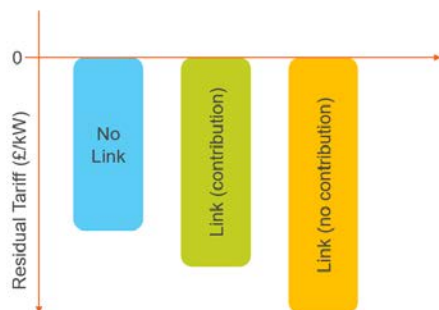

1

nationalgridESO

Comments: 1) *The Shetland case is used as a particular example in the WG report. It is assumed that savings in DNO assets and longer term operational costs could be treated the same way for other Island Groups.*

2) *We generally support the modification as it stands but request that renewal of an existing 33kV sub-sea cable to Orkney, which is due within a similar timeframe to the new transmission link, is considered in a similar way to the Shetland model described in the Workgroup consultation.*

Response: The modifications have been drafted and proposed to enable contributions to be applied in other island link scenarios. The specific contribution value methodologies, assessments and amounts are out with the CUSC modification process. The Proposer has confirmed that these points will be considered as part of those separate workstreams. These will progress this year, further to the Authority's intention to consult on the Western Isles and Orkney contributions, which it set out in its 2019 decision on SHEPD's contribution proposals.

Legal Text Comments

The Workgroup were supportive of the comments received on the legal text, and as such amendments have been made. The revised and final legal text can be found in Annex 7.

What is the impact of this change?

Who will it impact?

These modifications may have an impact on specific Distribution Network Operators, Transmission Owners, Remote Island Generators (Shetland, Western Isles and Orkney) if and to the extent that the Authority approves a DNO contribution. Depending on the classification of the node on the relevant island (Main Integrated Transmission System MITS or local) there may be an impact on the TNUoS Generator Residual tariff.

Depending also on this classification there will be a counter and corresponding impact on the Transmission Demand Residual and therefore Demand customers. A Workgroup member questioned if this modification would have any impact on the STC. The Proposer confirmed that there are no specific requirements to make changes to the STC or STCP's.

What are the positive impacts?

These Modifications support the [Authority's approved principle](#) of a licensed DNO making a contribution to a licensed TO, which recognises the value to the DNO (and its customers) of a new transmission asset provided by that TO.

CMP337 & CMP338 Workgroup Vote – assessment against CUSC charging and non-charging objectives.

The Workgroup met on the 13 May 2020 to carry out their workgroup vote. The full Workgroup vote can be found in Annex 8. The table below provides a summary of the Workgroup members view on the best option to implement this change.

CMP337 Workgroup Vote

The Applicable CUSC Objectives (Charging) are:

- (a) That compliance with the use of system charging methodology facilitates effective competition in the generation and supply of electricity and (so far as is consistent therewith) facilitates competition in the sale, distribution and purchase of electricity; Facilitating effective competition in the generation and supply of electricity, and (so far as consistent therewith) facilitating such competition in the sale, distribution and purchase of electricity;
- b) That compliance with the use of system charging methodology results in charges which reflect, as far as is reasonably practicable, the costs (excluding any payments between transmission licensees which are made under and accordance with the STC) incurred by transmission licensees in their transmission businesses and which are compatible with standard licence condition C26 requirements of a connect and manage connection);
- (c) That, so far as is consistent with sub-paragraphs (a) and (b), the use of system charging methodology, as far as is reasonably practicable, properly takes account of the developments in transmission licensees' transmission businesses;
- (d) Compliance with the Electricity Regulation and any relevant legally binding decision of the European Commission and/or the Agency. These are defined within the National Grid Electricity Transmission plc Licence under Standard Condition C10, paragraph 1 *; and
- (e) Promoting efficiency in the implementation and administration of the CUSC arrangements.

*Objective (d) refers specifically to European Regulation 2009/714/EC. Reference to the Agency is to the Agency for the Cooperation of Energy Regulators (ACER).

Workgroup Member	BEST Option?	Which objective does the change better facilitate? (if baseline not applicable)
Eleanor Horn– National Grid ESO	Original	(b) and (e)
Rachel Kettles - SHEPD	Original	(a) (b) (c) and (e)
Paul Mott – EDF Energy	Original	(b) and (e)
John Tindal – SSE Renewables Developments UK Ltd	Original	(b) and (d)
Sharron Gordon – SSE - Transmission Operator	Original	(a) (b) (c) and (e)
Dennis Gowland - Neven Point Wind Ltd	Original	(a) (b) and (d)

The Workgroup unanimously agreed that CMP337 better facilitates the CUSC charging objectives and that the change should be implemented.

CMP338 Workgroup Vote

The Applicable CUSC Objectives (Non -Charging) are:

- (a) The efficient discharge by the Licensee of the obligations imposed on it by the Act and the Transmission Licence;
- (b) Facilitating effective competition in the generation and supply of electricity, and (so far as consistent therewith) facilitating such competition in the sale, distribution and purchase of electricity;
- (c) Compliance with the Electricity Regulation and any relevant legally binding decision of the European Commission and/or the Agency *; and
- (d) Promoting efficiency in the implementation and administration of the CUSC arrangements.

*Objective (c) refers specifically to European Regulation 2009/714/EC. Reference to the Agency is to the Agency for the Cooperation of Energy Regulators (ACER).

Workgroup Member	BEST Option?	Which objective does the change better facilitate? (if baseline not applicable)
Eleanor Horn– National Grid ESO	Original	(d)
Rachel Kettles - SHEPD	Original	(a) (b) and (d)
Paul Mott – EDF Energy	Original	(a)
John Tindal – SSE Renewables Developments UK Ltd	Original	(b) and (d)
Sharron Gordon – SSE - Transmission Operator	Original	(a) (b) and (d)
Dennis Gowland - Neven Point Wind Ltd	Original	(a) (b) and (c)

The Workgroup unanimously agreed that CMP338 better facilitates the CUSC objectives and that the change should be implemented.

Code Administrator Consultation responses

The Code Administrator Consultation was issued on the 20 May 2020 and closed on 26 May 2020 (2pm). One response was received and can be found in the table below, the full response can be found in Annex 9.

CMP337

Code Administrator Consultation summary	
Question	
Do you believe that the CMP337 Original Proposal better facilitates the Applicable CUSC (Charging) Objectives?	Yes, we believe that the CMP 337 original proposal better facilitates all of the CUSC charging objectives
Do you support the proposed implementation approach?	Yes, we support the proposed implementation approach
Do you have any other comments?	
Legal text issues raised in the Consultation	
<i>No legal text issues raised in the Consultation.</i>	

CMP338

Code Administrator Consultation summary	
Question	
Do you believe that the CMP338 Original Proposal better facilitates the Applicable CUSC Objectives?	Yes, we believe that the CMP 338 original proposal better facilitates all of the CUSC charging objectives
Do you support the proposed implementation approach?	Yes, we support the proposed implementation approach
Do you have any other comments?	
Legal text issues raised in the Consultation	
<i>No legal text issues raised in the Consultation.</i>	

When will this change take place?**Implementation date:**

A decision on CMP337 and CMP338 is needed in June 2020. The modifications must be in effect by 1 April of TNUoS charging year 2024, which is expected to be the point at which the Shetland link is made available to users.

Implementation approach:

It is critical that the modification is made in timely manner in order to ensure that consumer savings and benefits are realised, which in the case of Shetland is anticipated to deliver savings to consumers of c.£140m. Finalisation of these CUSC modifications is a prerequisite for developer commitment to the Shetland transmission link, which, in turn, is a prerequisite for the link's approval.

Acronym table and reference material

Acronym	Meaning
AAHEDC	Assistance for Areas with High Distribution Costs
CMP	CUSC Modification Proposal
CUSC	Connection Use of System Code
DNO	Distribution Network Operators
MITS	Main Interconnected Transmission System
HBRS	Hydro Benefit Replacement Scheme
NGESO	National Grid Electricity System Operator
STC	System Operator Transmission Owner Code
STCP	System Operator Transmission Owner Procedures
TDR	Transmission Demand Residual
TNUoS	Transmission Network Use of System

TO	Transmission Owners
----	---------------------

Reference material:

1. [Decision – 17 December 2019 Authority Decision – 17 December 2019](#)
2. [CMP303 'Improving Local Circuit Charge Cost – Reflectivity](#)
3. [CMP320 'Island MITs Radial Link Security Factor](#)
4. [CMP317/CMP327 'Removing Generator Residual and excluding assets required for connection'](#)
5. [CMP324/CMP325 'Generation Zones – changes for RIIO-T2 & re-zoning CMP324 expansion'](#)
6. [BEIS decision - 13 February 2020](#)
7. [Authority decision on urgency, April 2020](#)
8. [Authority consultation minded to approved Shetland transmission link, April 2020](#)

Annexes

Annex	Information
Annex 1	CMP337 & CMP338 Proposal Forms
Annex 2	Terms of Reference
Annex 3	Urgency Letters for CMP337 & CMP338
Annex 4	Scenario Analysis
Annex 5	Original Legal Text
Annex 6	Workgroup Consultation Responses
Annex 7	Final Legal Text
Annex 8	Workgroup Vote
Annex 9	Code Administrator Consultation responses