

Offshore BMU Configuration



Steve Curtis

Offshore: System Operator role

- Need to:

- Manage Transmission Flows ($\geq 132\text{kV}$)

- Achieve by Dispatching BMUs

- Therefore BMUs must discretely manage transmission flows

- i.e. Must understand relationship of BMUs to flow routes

- BMUs Must not parallel MITS

- Manage Fault Levels

- Need to know constitution of PPM and discrete fault infeeds

- Coordinate switching

- Which switches?

Offshore Network Definitions

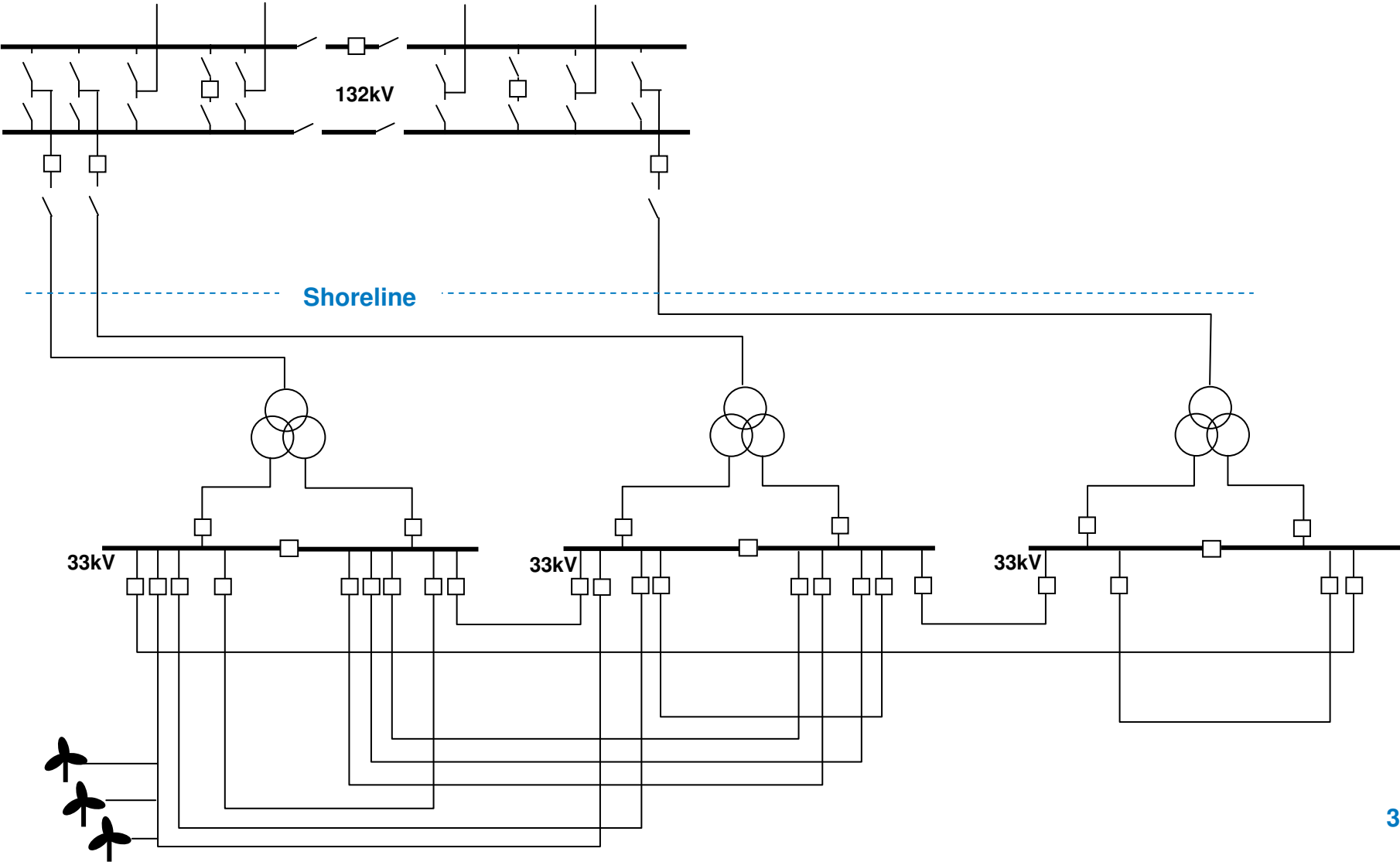

Offshore Network Definitions

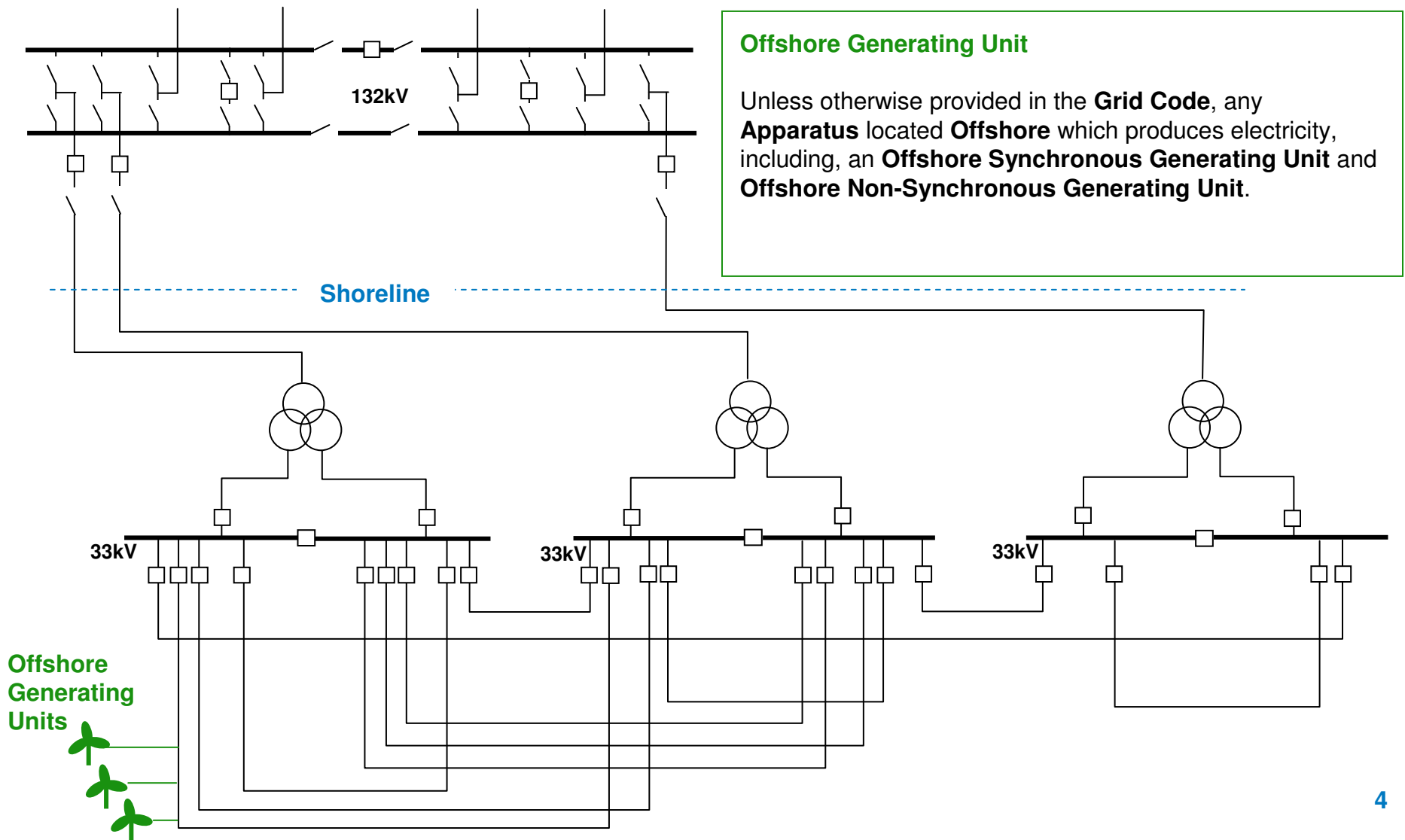

Offshore Network Definitions

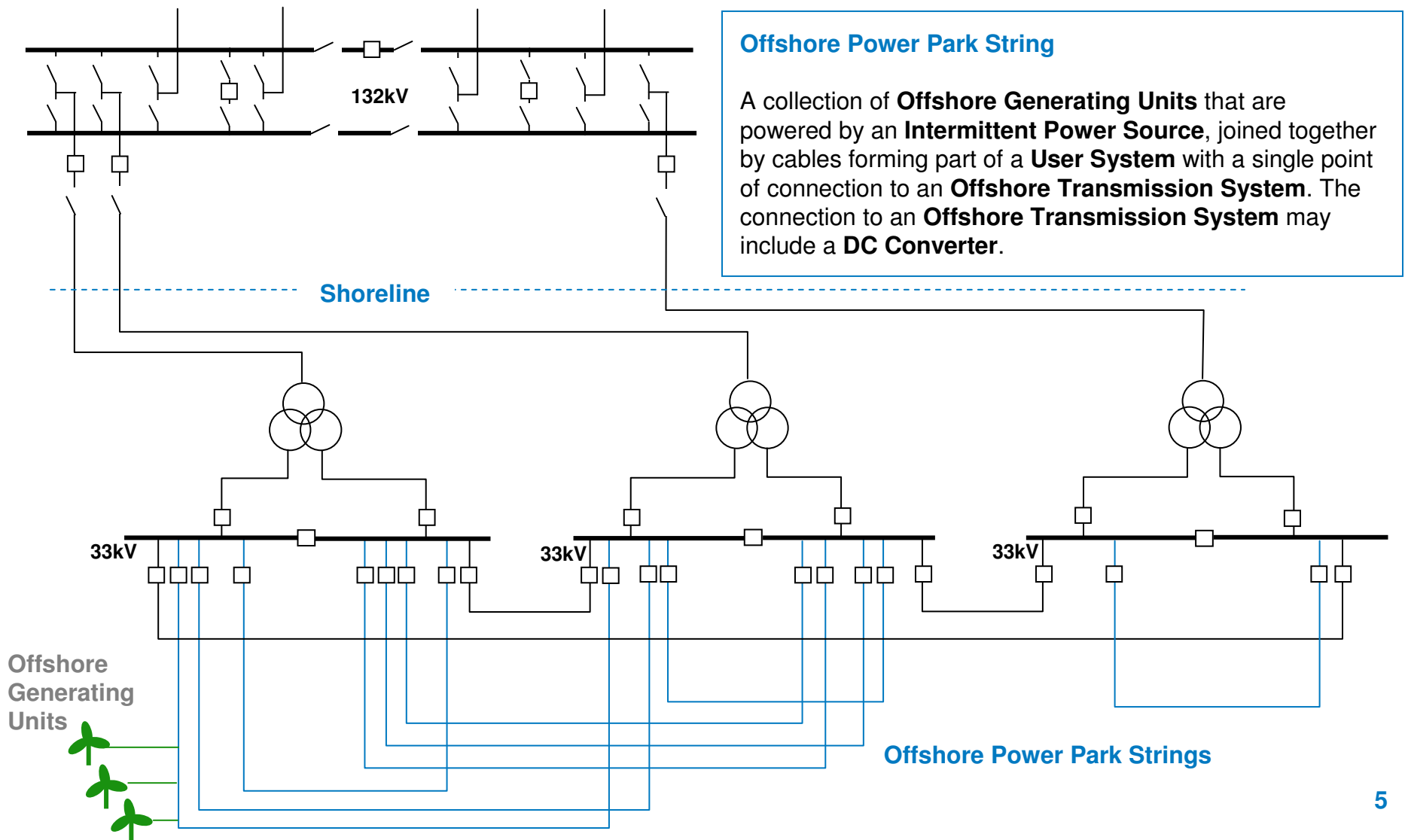

Offshore Network Definitions

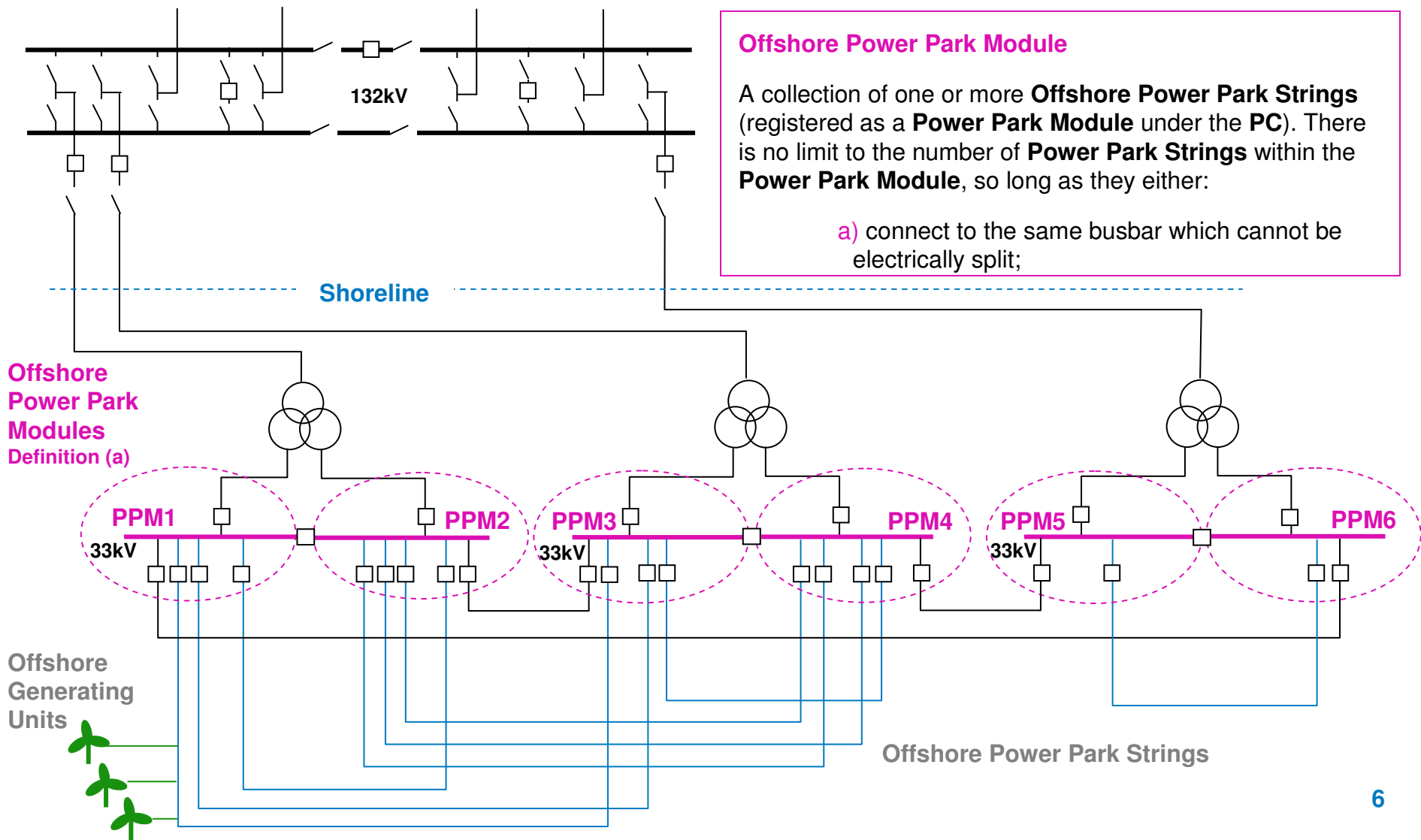

Offshore Power Park Module

A collection of one or more **Offshore Power Park Strings** (registered as a **Power Park Module** under the **PC**). There is no limit to the number of **Power Park Strings** within the **Power Park Module**, so long as they either:

a) connect to the same busbar which cannot be electrically split;

Offshore Power Park Modules Definition (a)

Offshore Generating Units

Offshore Power Park Strings

Offshore Network Definitions

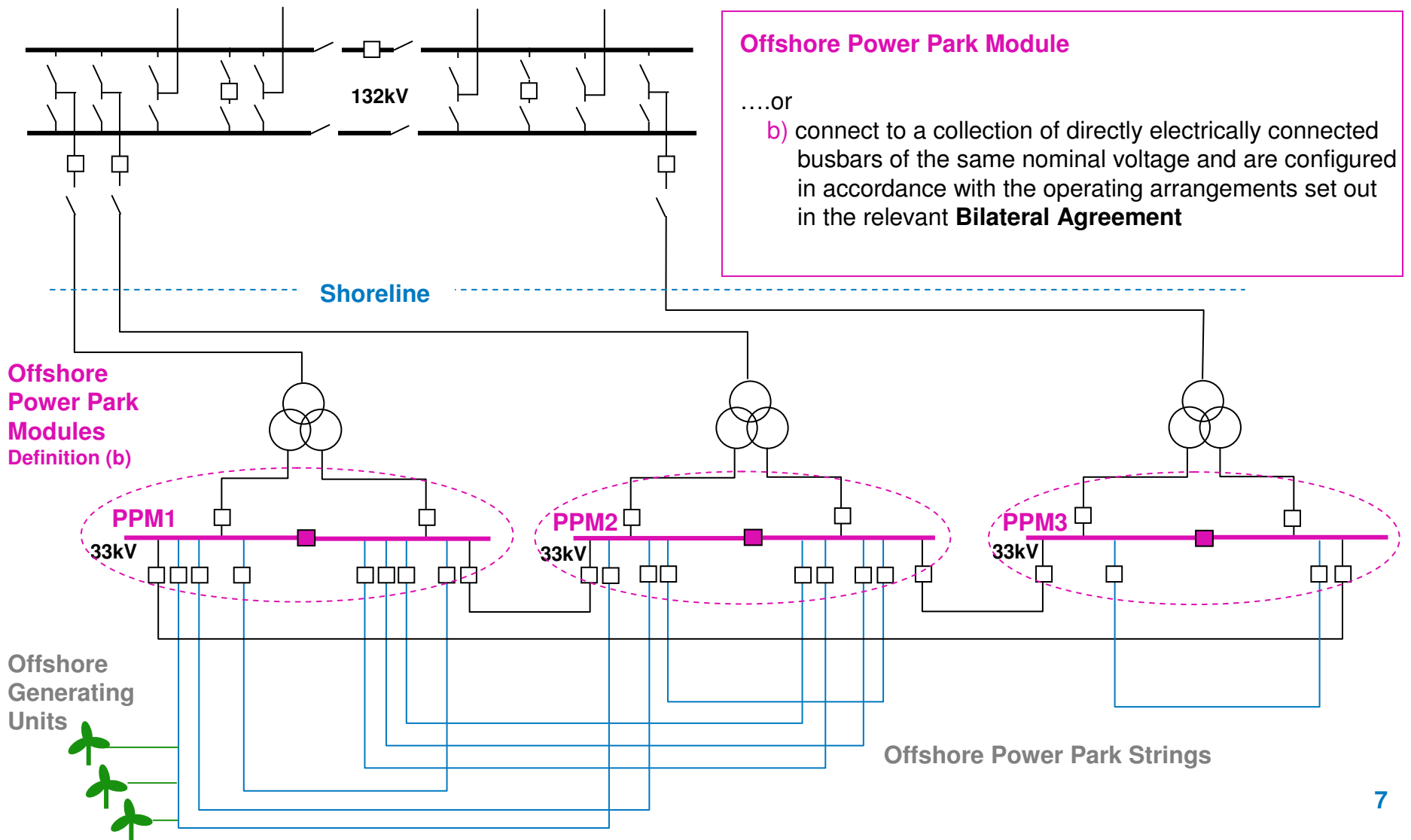

Offshore Network Definitions

Offshore Power Park Module

....or

b) connect to a collection of directly electrically connected busbars of the same nominal voltage and are configured in accordance with the operating arrangements set out in the relevant **Bilateral Agreement**

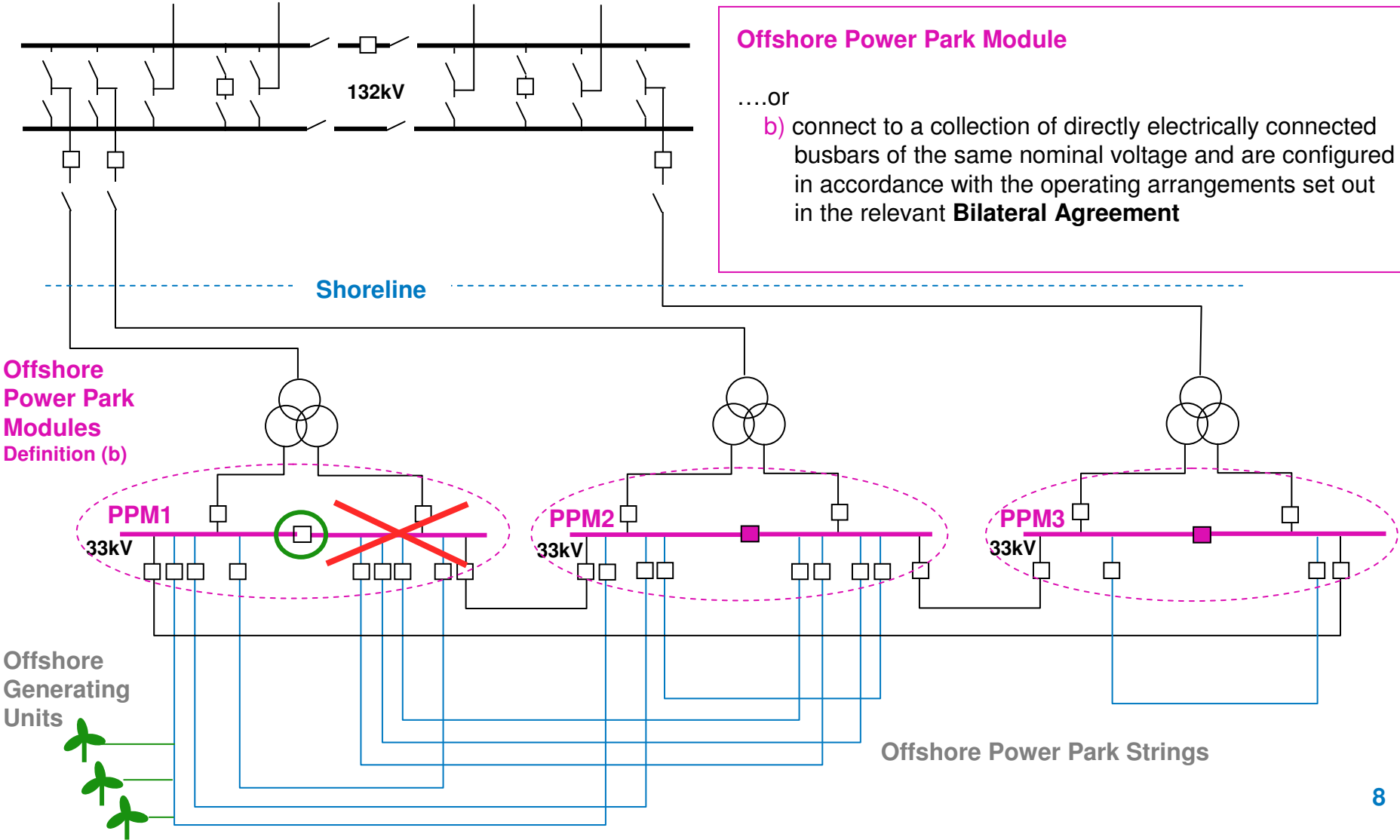

Offshore Network Definitions

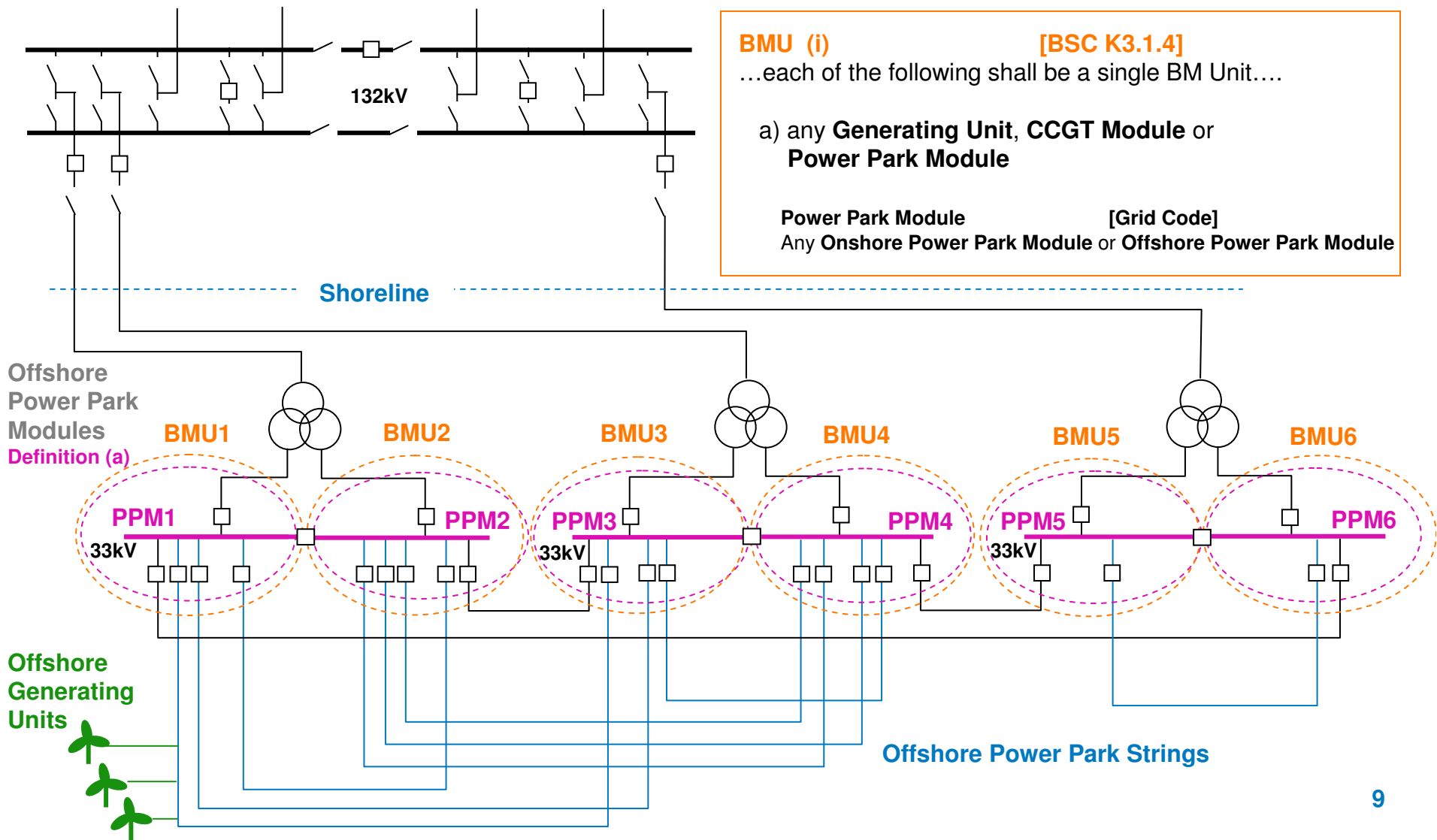

Offshore Network Definitions

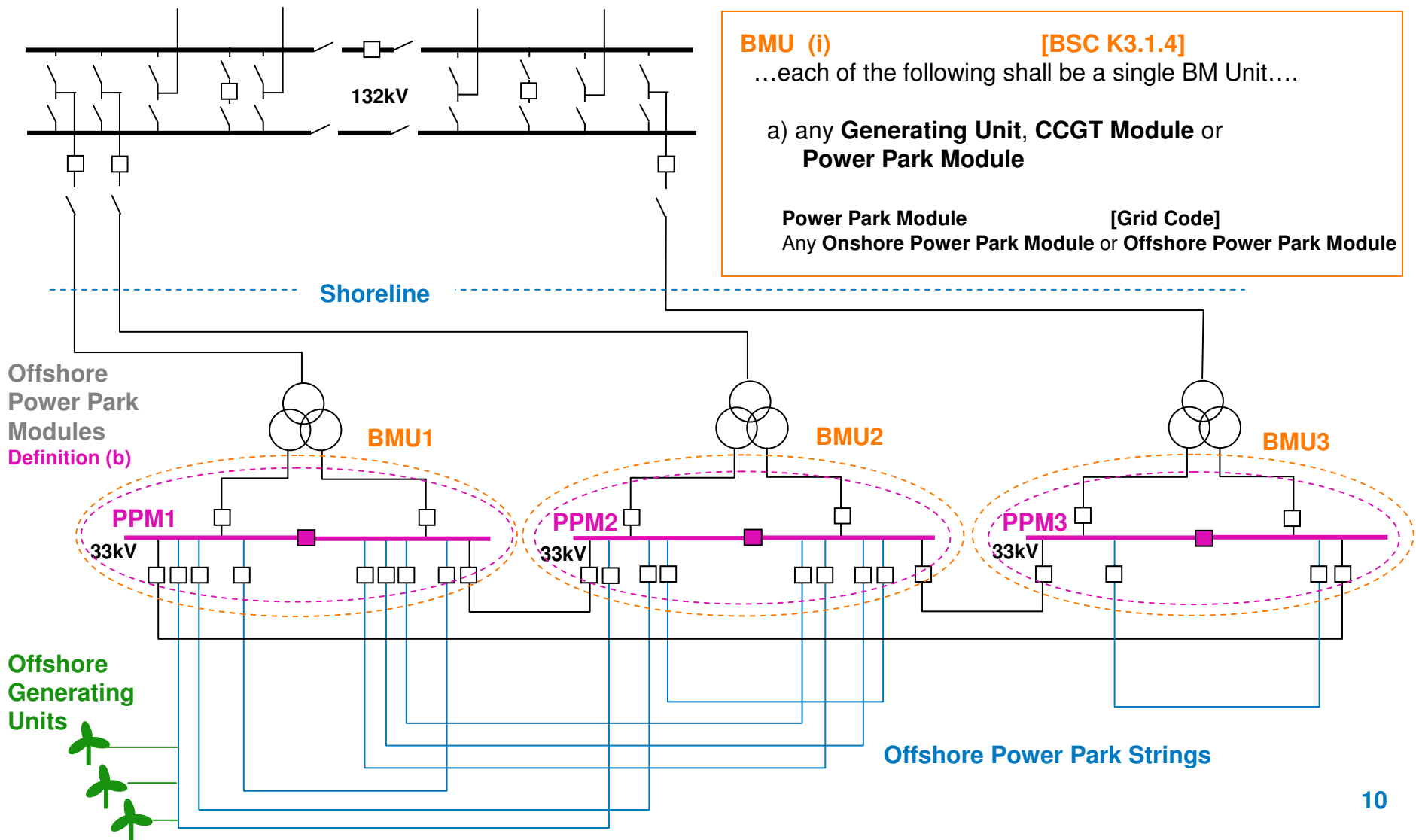

Offshore Network Definitions

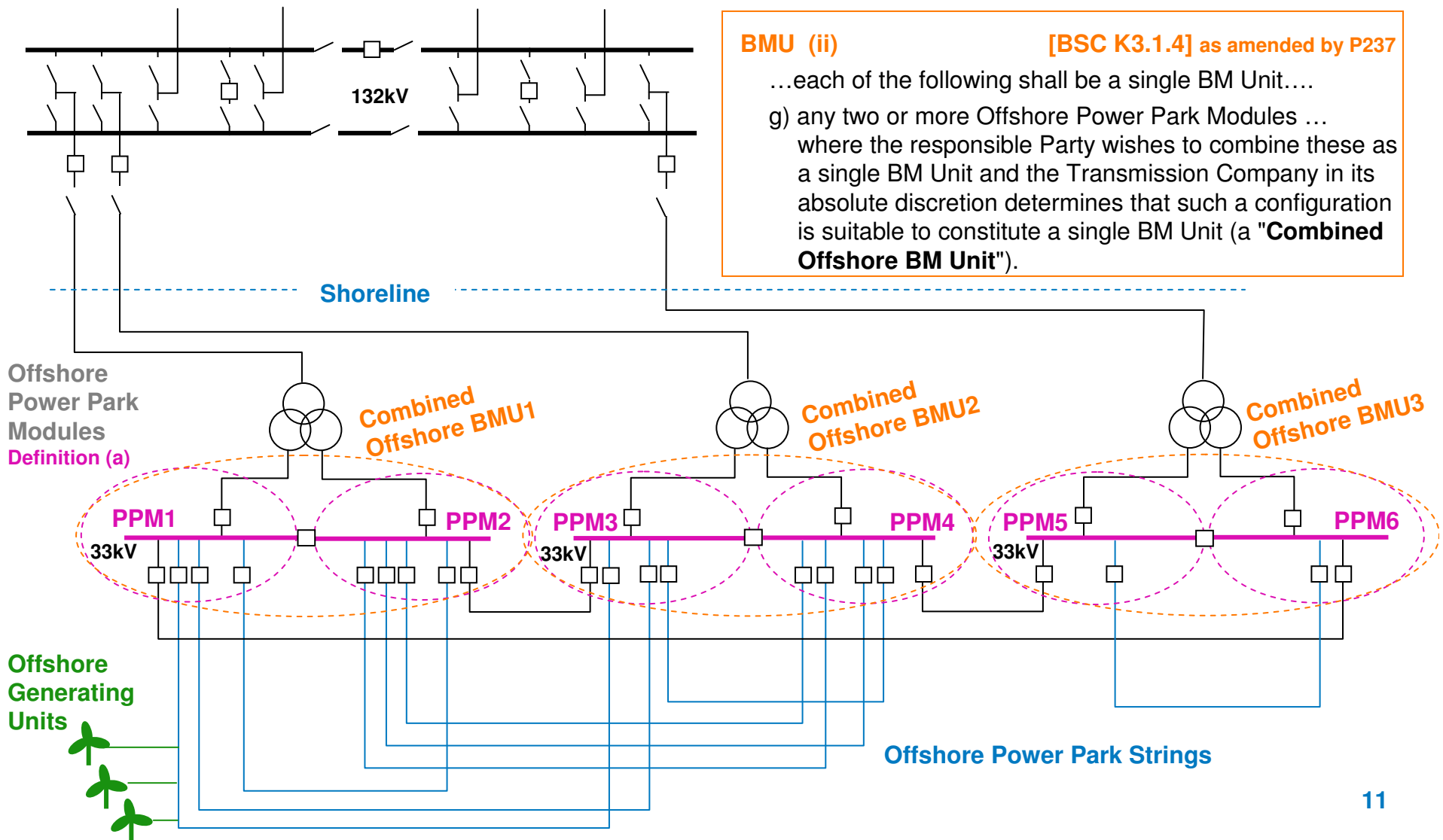

Offshore Network Definitions

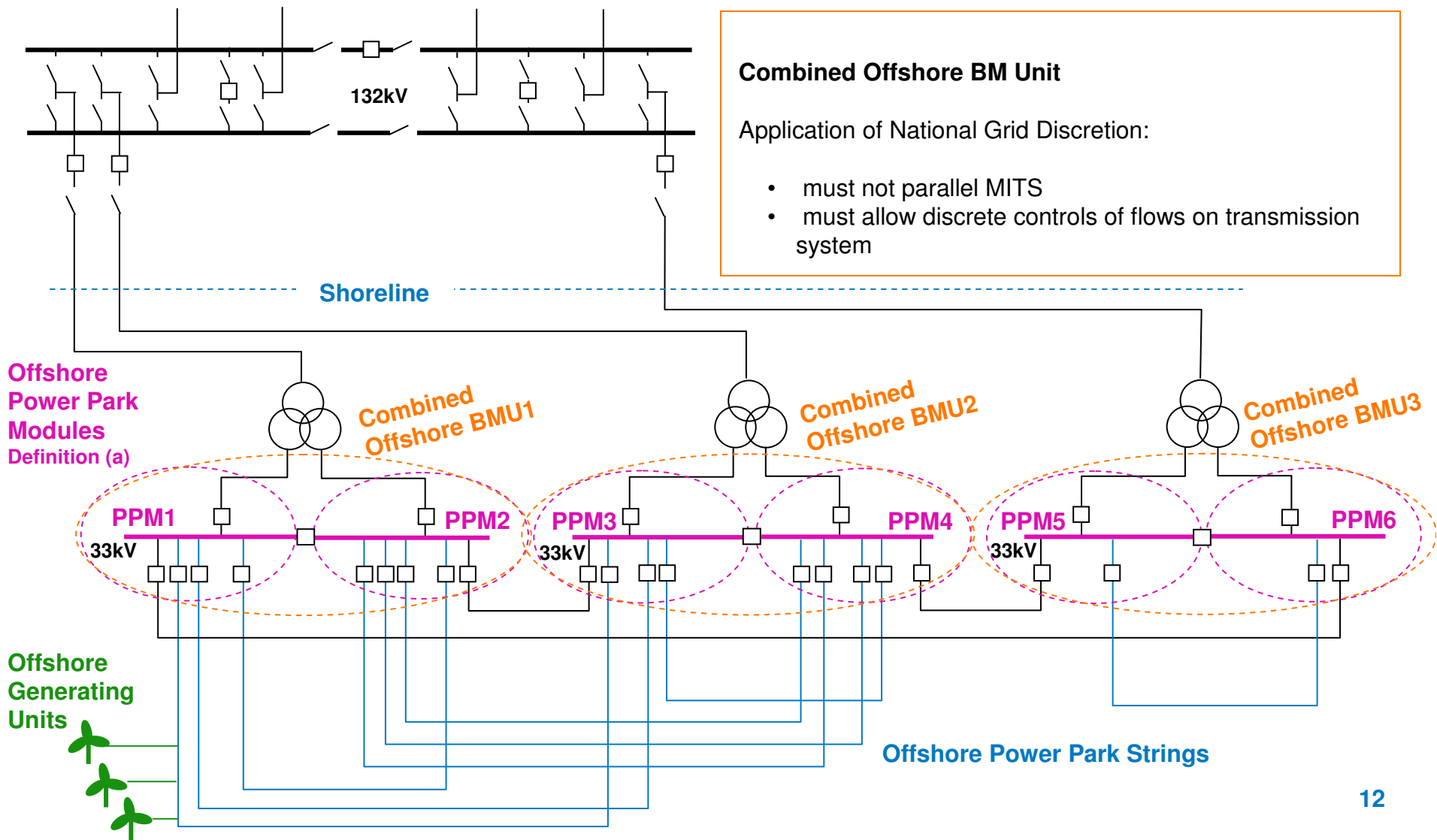

Offshore Network Definitions

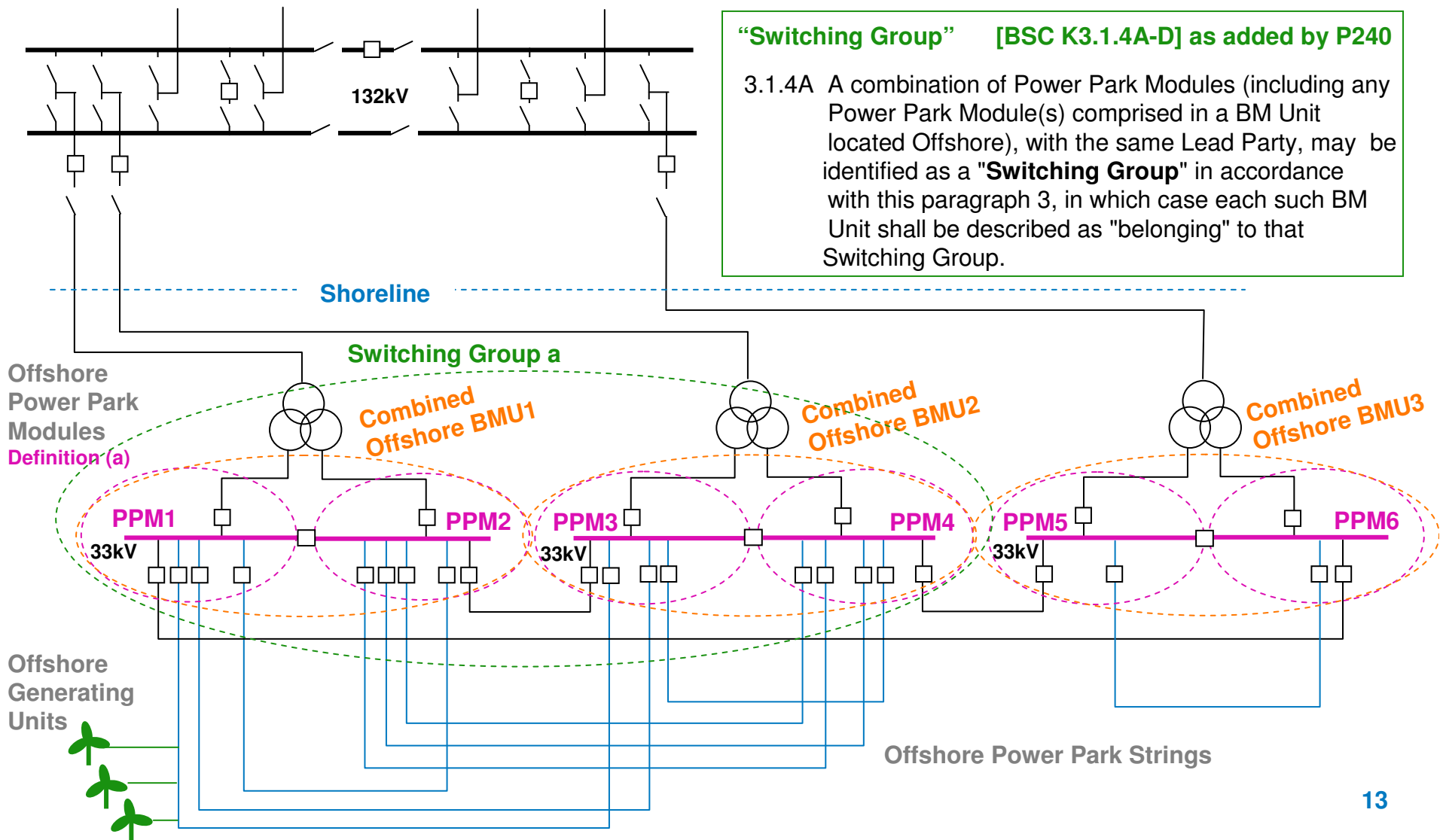

Offshore Network Definitions

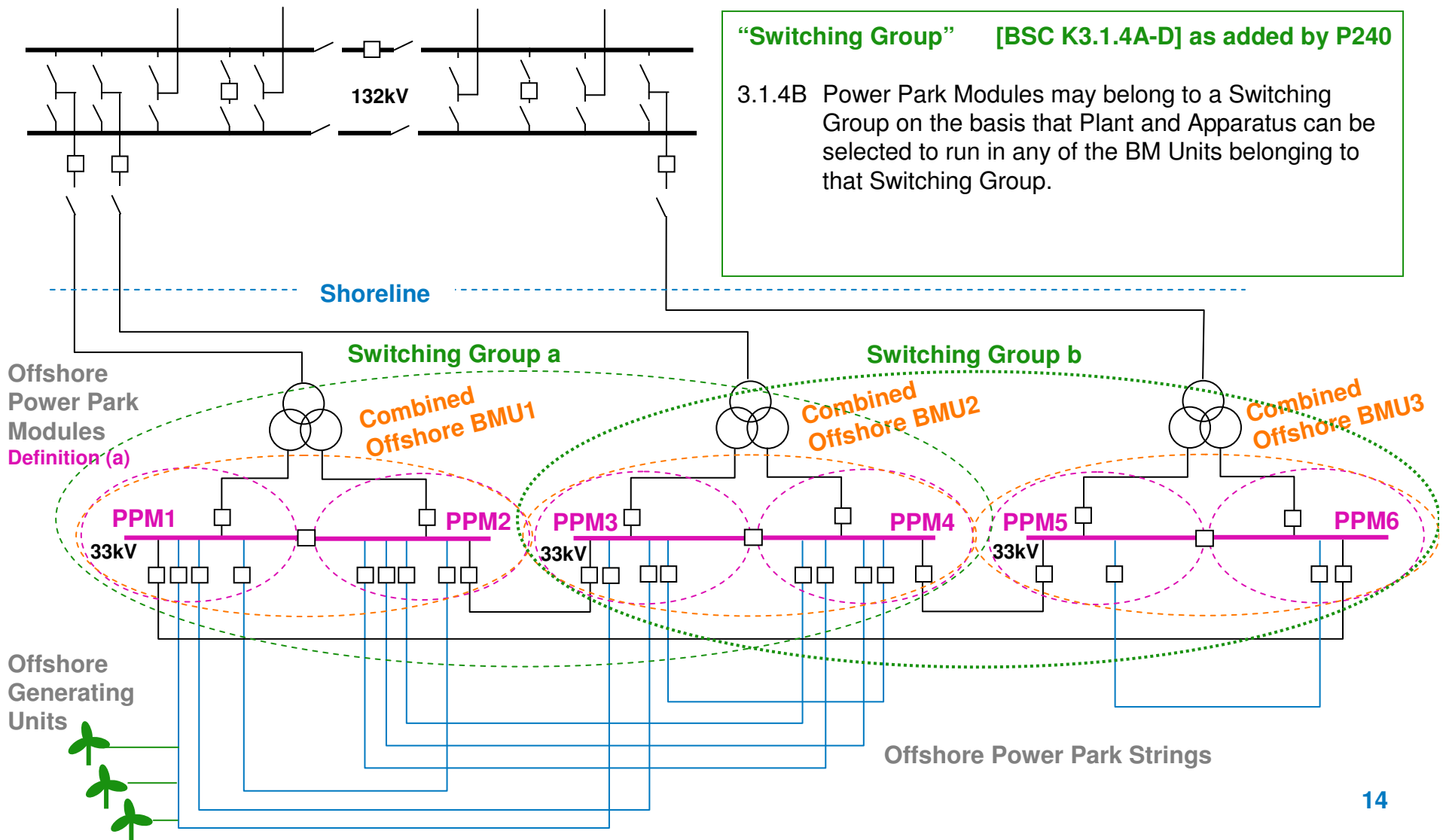

Offshore Network Definitions

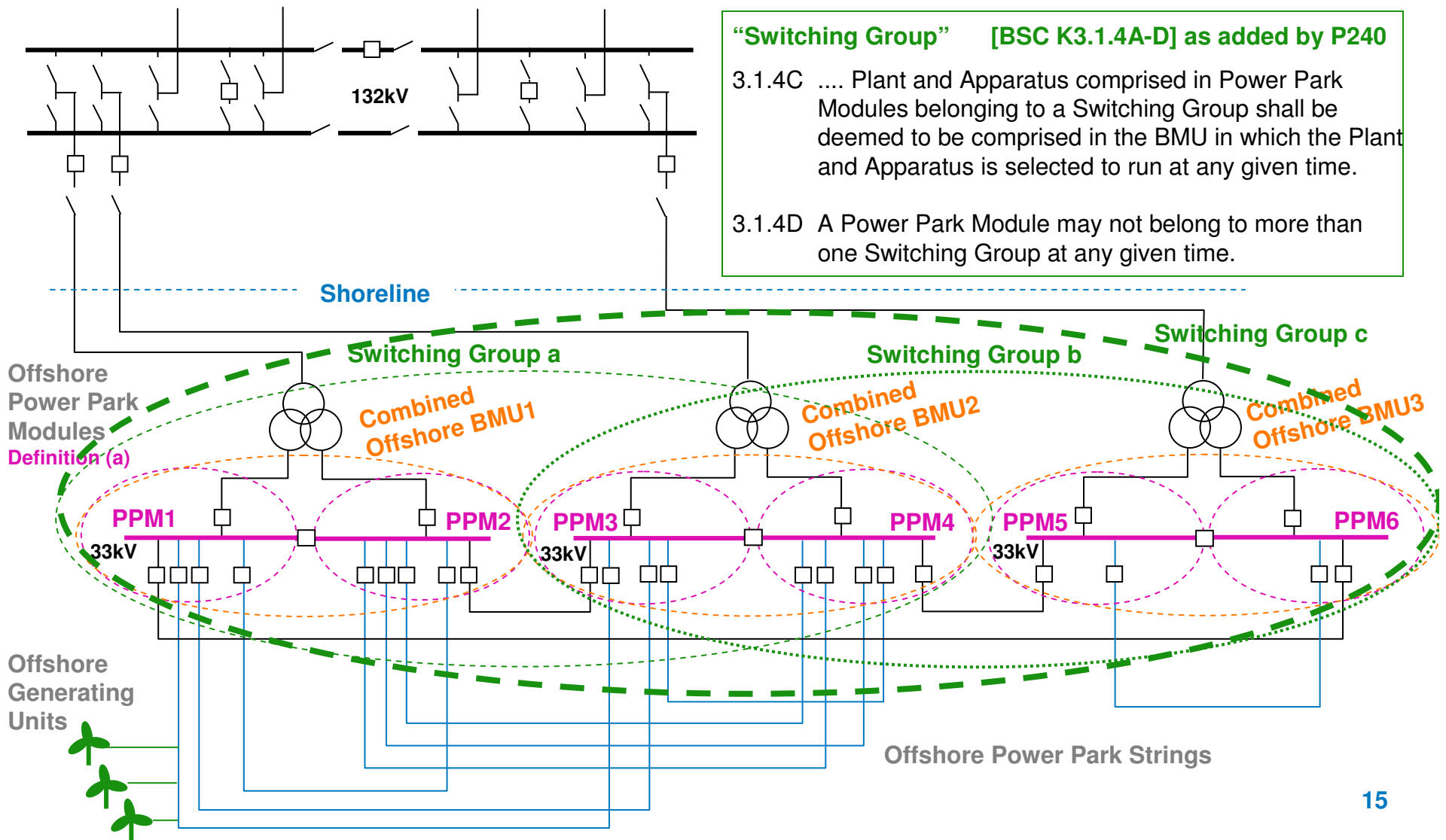

PPM Availability Matrix

BC1.A.1.8 Power Park Module Availability Matrix

BC1.A.1.8.1 **Power Park Module Availability Matrix** showing the number of each type of **PowerPark Units** expected to be available is illustrated in the example form below. The **Power Park Module Availability Matrix** is designed to achieve certainty in knowing the number of **Power Park Units Synchronised** to meet the **Physical Notification** and to achieve a **Bid-Offer Acceptance**.

Power Park Module Availability Matrix example form

POWER PARK UNIT AVAILABILITY	POWER PARK UNITS			
	Type A	Type B	Type C	Type D
Description (Make/Model)				
Number of units				

Offshore Network Switching Examples

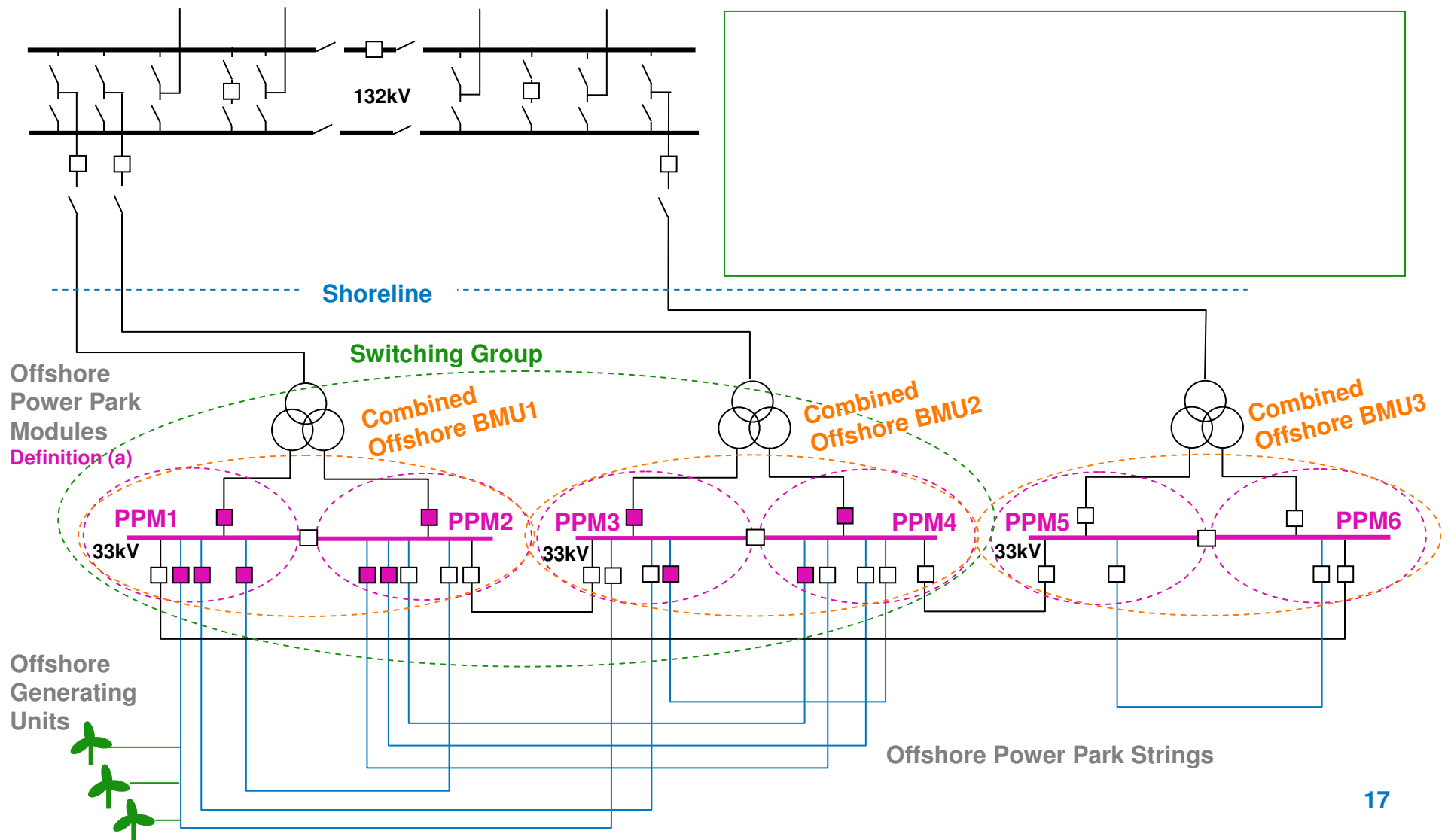

Offshore Network Switching Examples

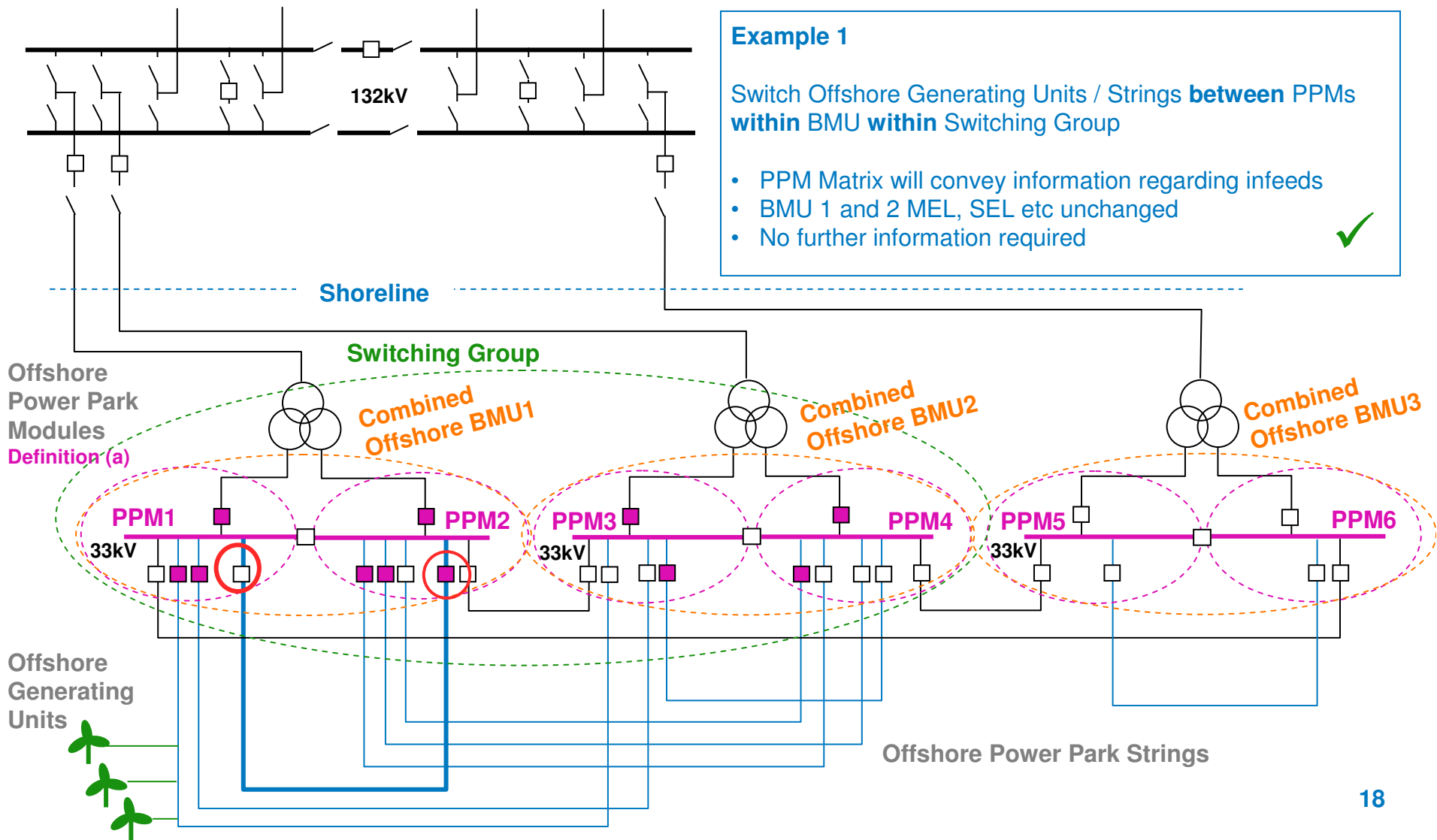

Offshore Network Switching Examples

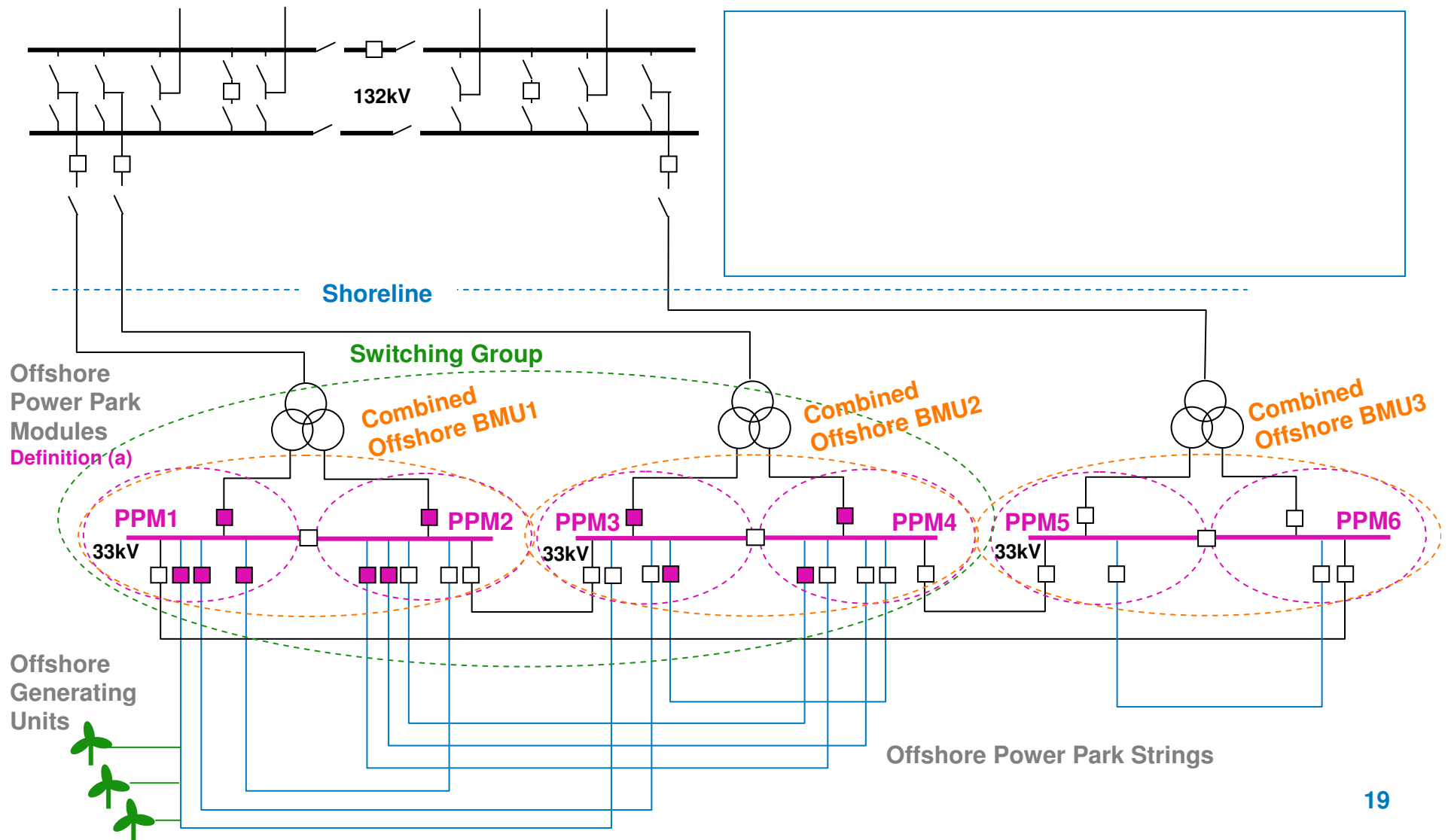

Offshore Network Switching Examples

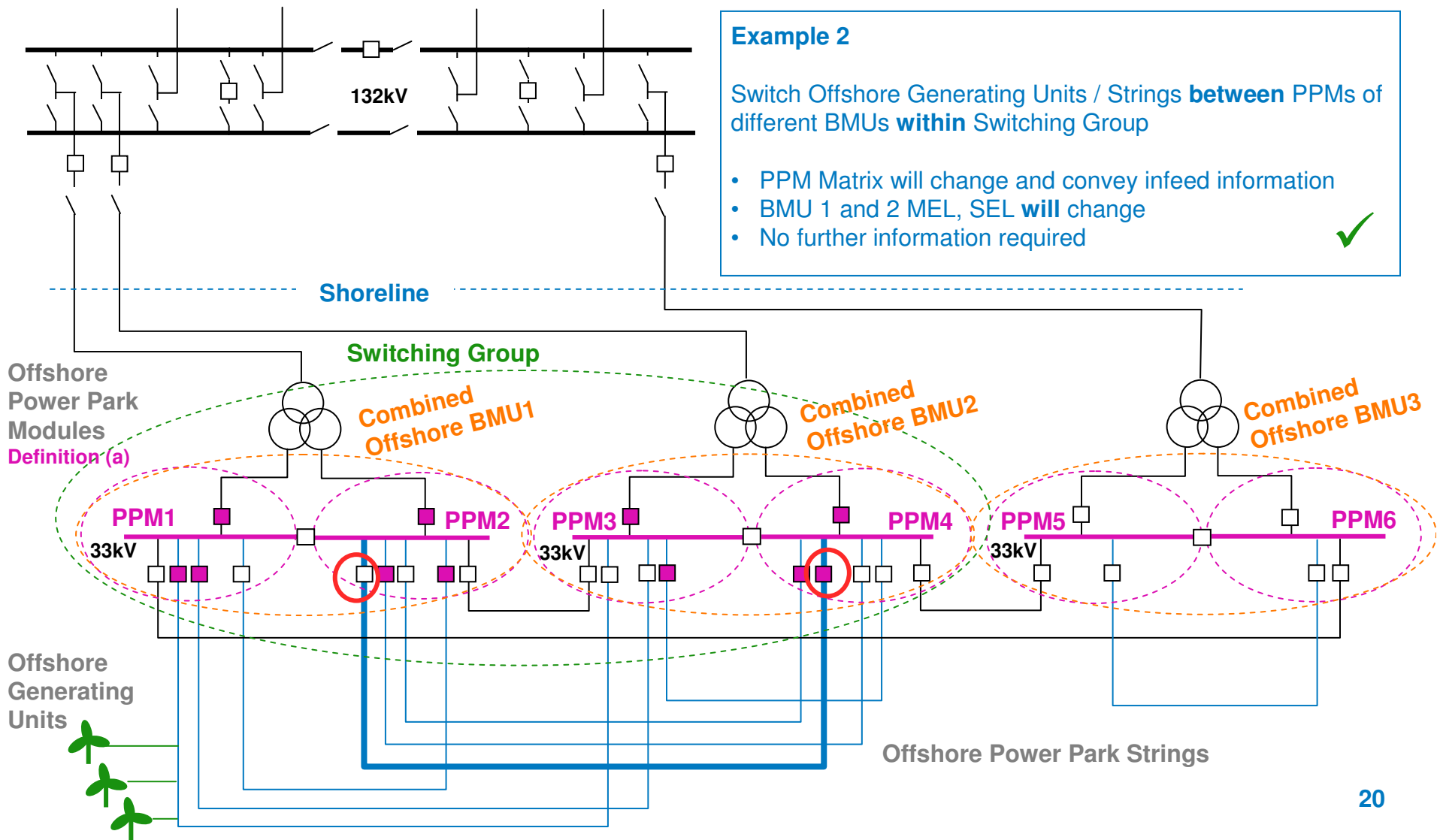

Example 2

Switch Offshore Generating Units / Strings **between** PPMs of different BMUs **within** Switching Group

- PPM Matrix will change and convey infeed information
- BMU 1 and 2 MEL, SEL **will** change
- No further information required

✓

Offshore Network Switching Examples

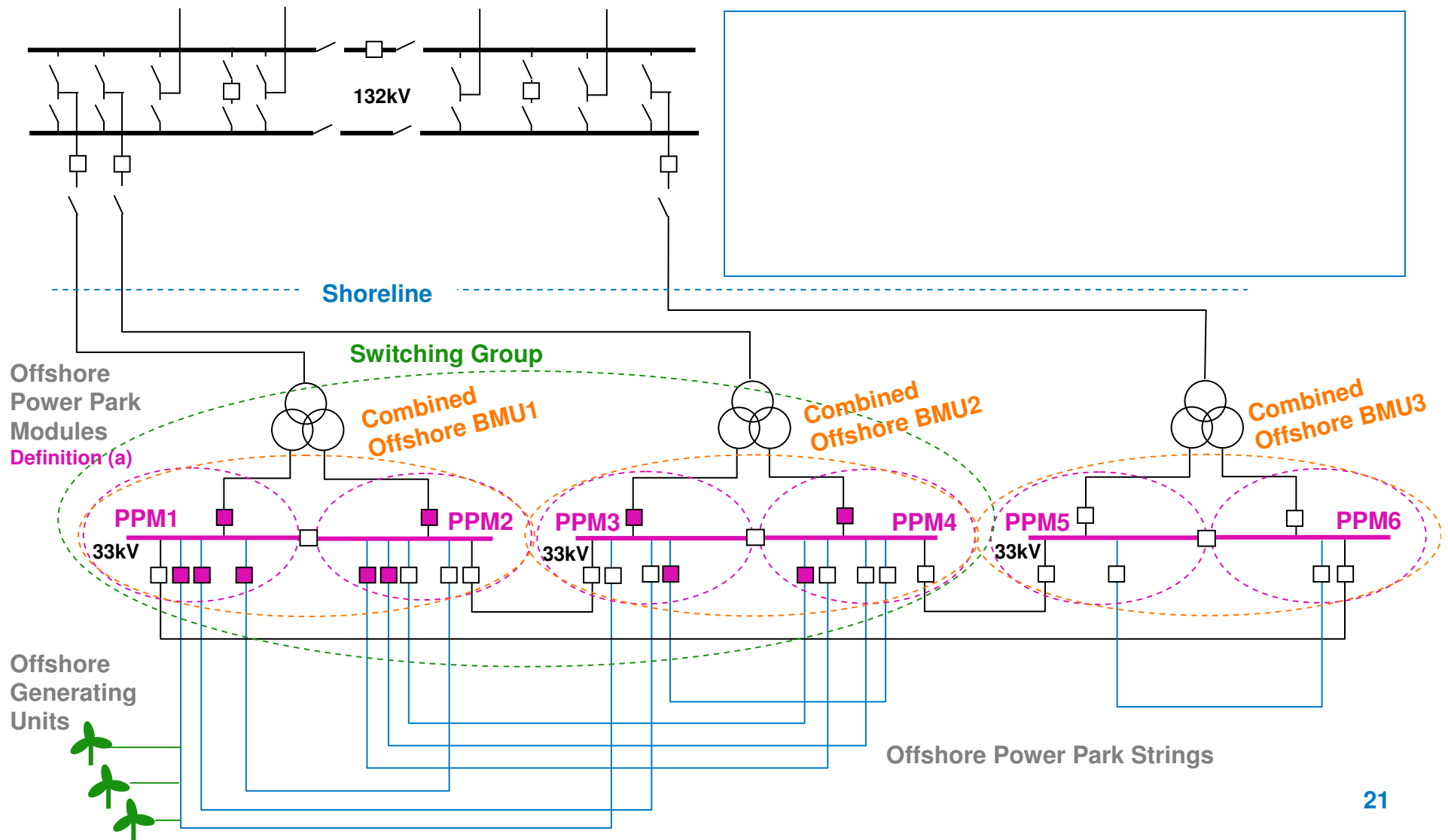

Offshore Network Switching Examples

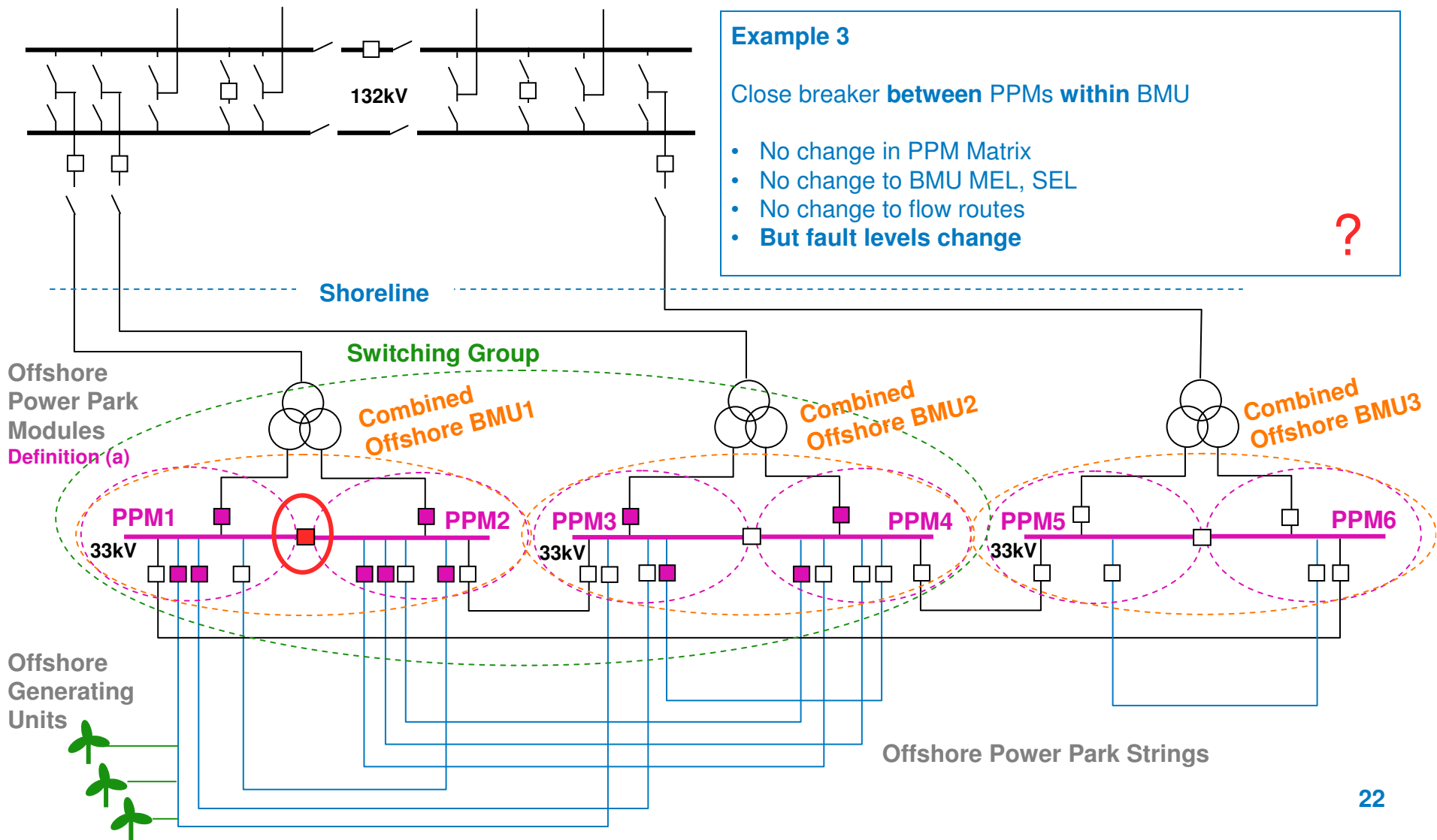

Example 3

Close breaker **between** PPMs **within** BMU

- No change in PPM Matrix
- No change to BMU MEL, SEL
- No change to flow routes
- **But fault levels change**

?

Offshore Network Switching Examples

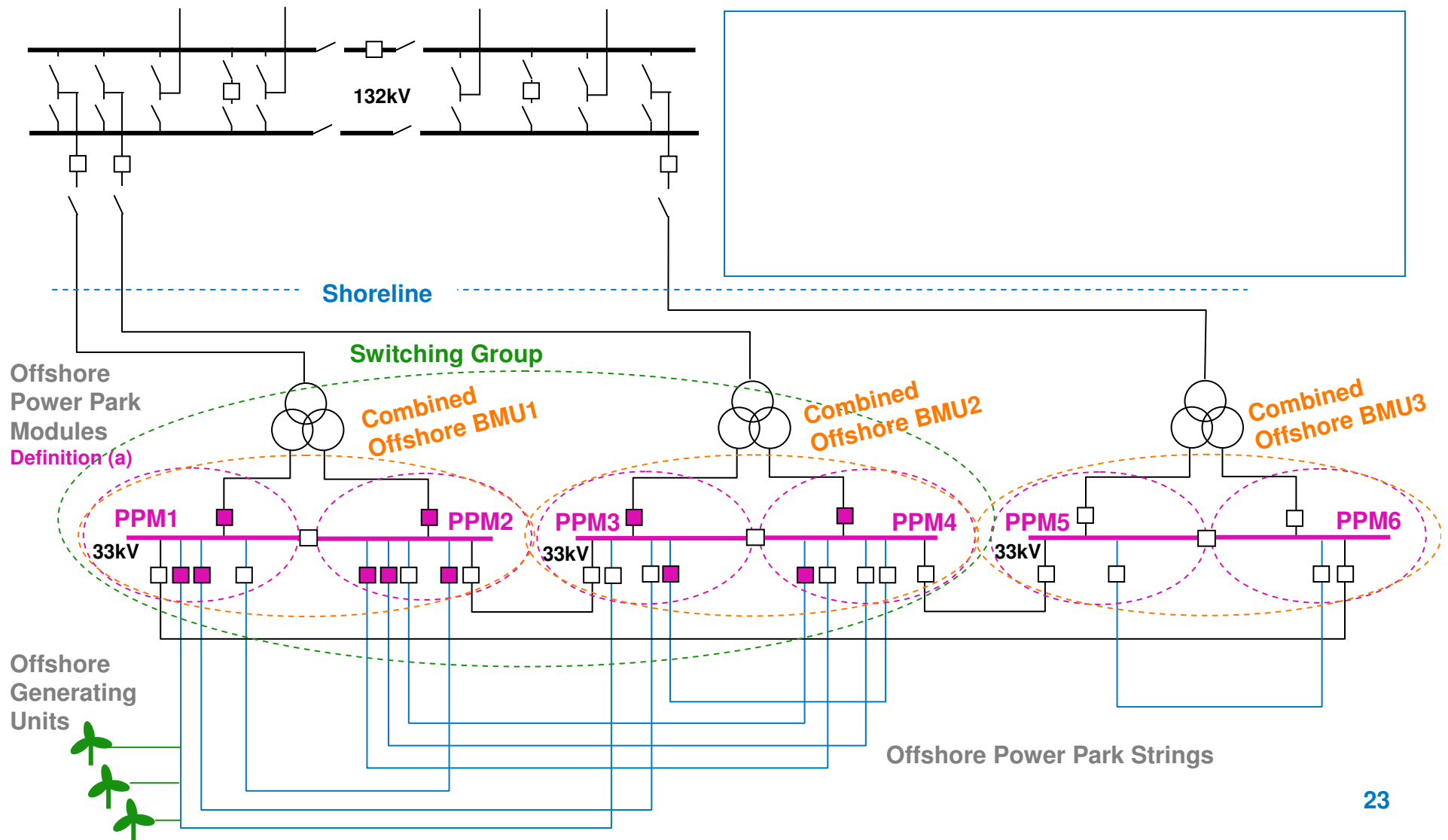

Offshore Network Switching Examples

Example 4

Close breakers **between PPMs between BMUs within** Switching group (NB cannot parallel MITS, but several permissible options)

- No change in PPM Matrices
- **But Fault levels change**
- BMU 1 and 2 MEL, SEL **will change**
- **Flow routes change**

?

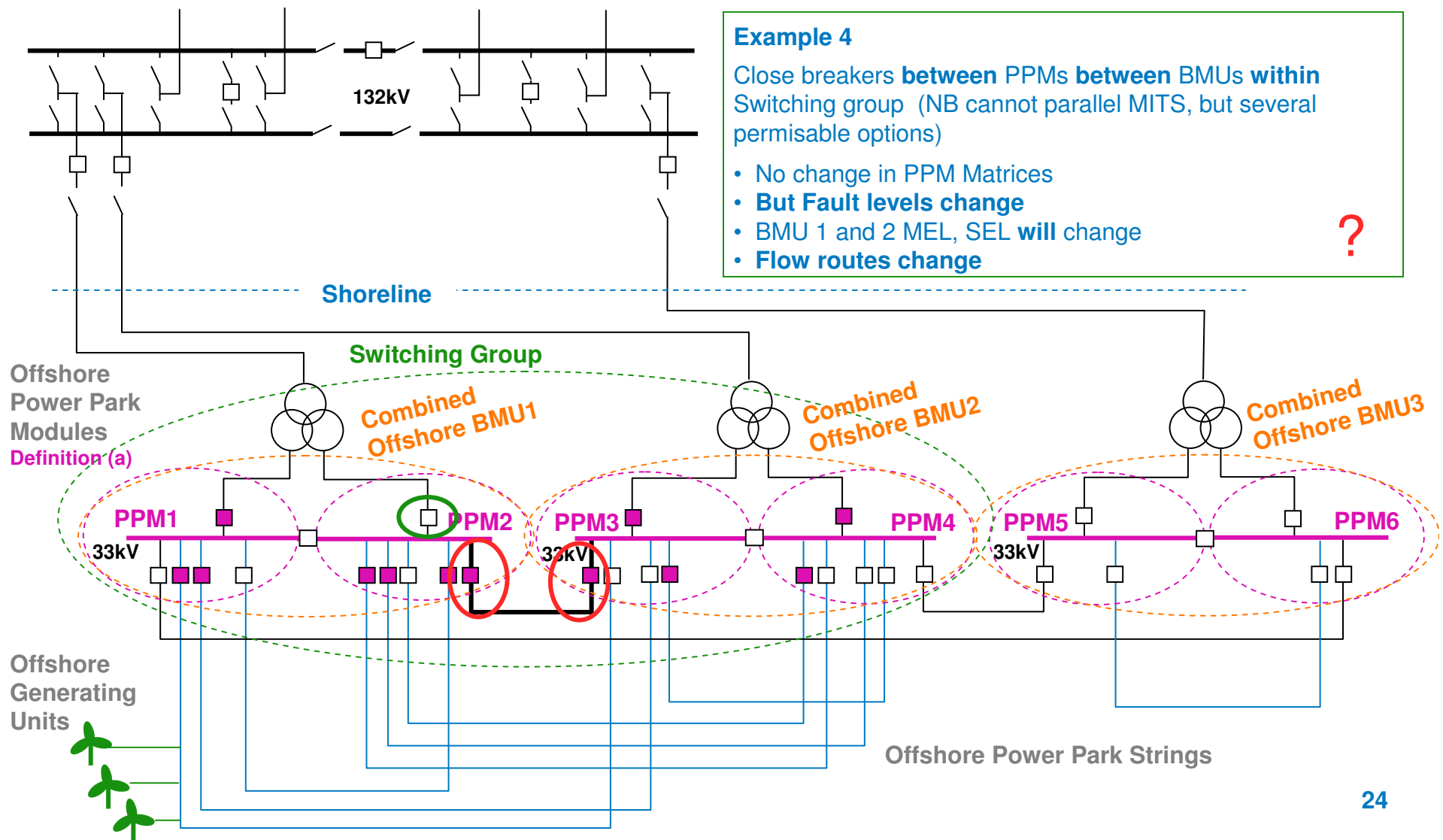

Offshore Network Switching Examples

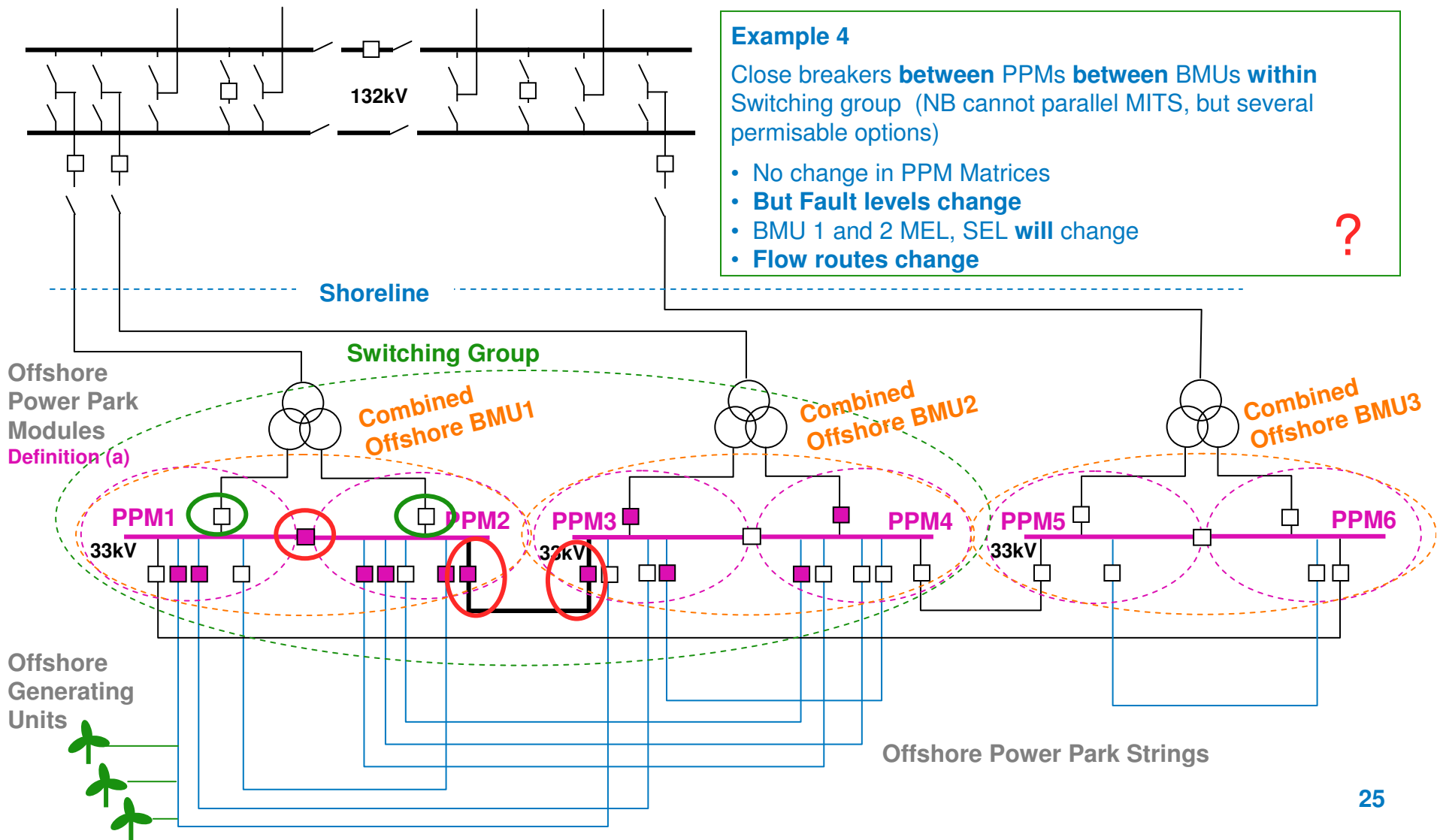

Example 4

Close breakers **between PPMs between BMUs within** Switching group (NB cannot parallel MITS, but several permissible options)

- No change in PPM Matrices
- **But Fault levels change**
- BMU 1 and 2 MEL, SEL **will change**
- **Flow routes change**



Offshore: System Operator role

- Need to:
 - Manage Transmission Flows ($\geq 132\text{kV}$)
 - Achieve by Dispatching BMUs
 - Therefore BMUs must discretely manage transmission flows
 - BMUs Must not parallel MITS
 - Must understand relationship of BMUs to flow routes
 - Configuration of BMUs required
 - Manage Fault Levels
 - Need to know constitution of PPM and discrete fault infeeds
 - PPM Matrix states how many turbines of each type in each PPM
 - But what is configuration of PPMs within BMUs /Switching
 - Configuration of BMUs required
 - Coordinate switching
 - Which switches?
 - Intended switch status of all switches System Operator operates

BMU Configuration Diagram

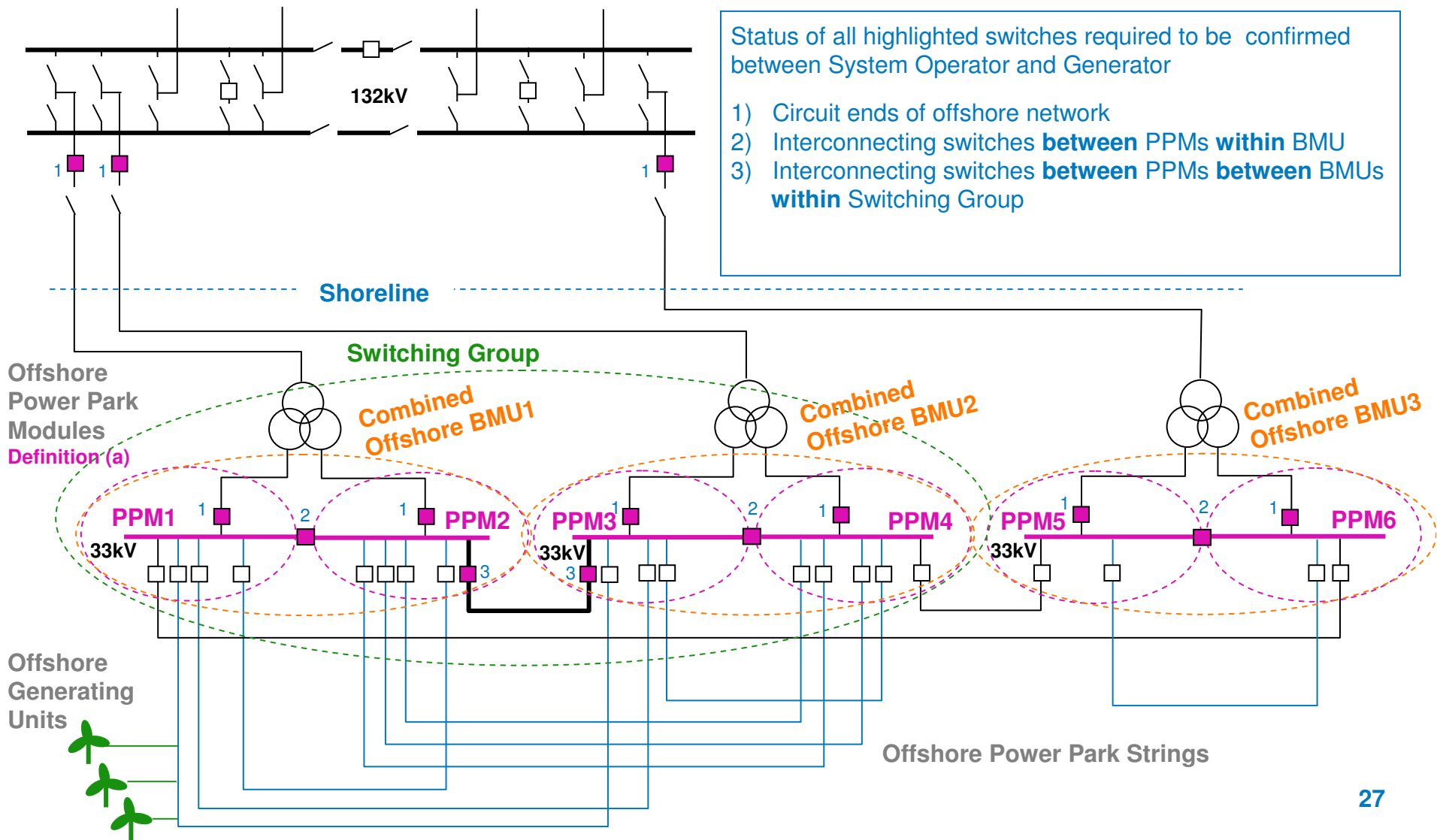

BMU Configuration Diagram

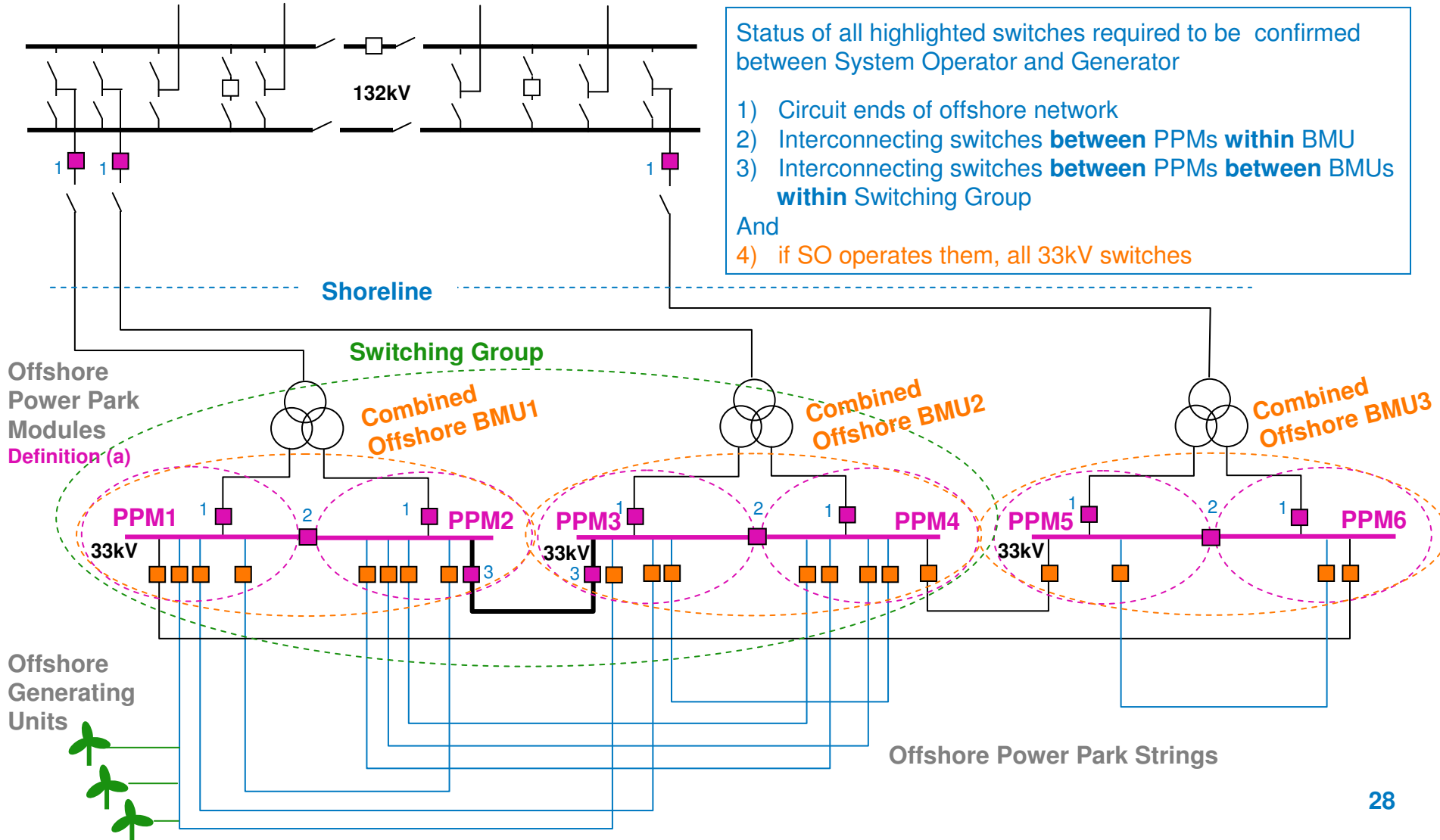

Status of all highlighted switches required to be confirmed between System Operator and Generator

- 1) Circuit ends of offshore network
 - 2) Interconnecting switches **between** PPMs **within** BMU
 - 3) Interconnecting switches **between** PPMs **between** BMUs **within** Switching Group
- And
- 4) if SO operates them, all 33kV switches

BMU Configuration Diagram

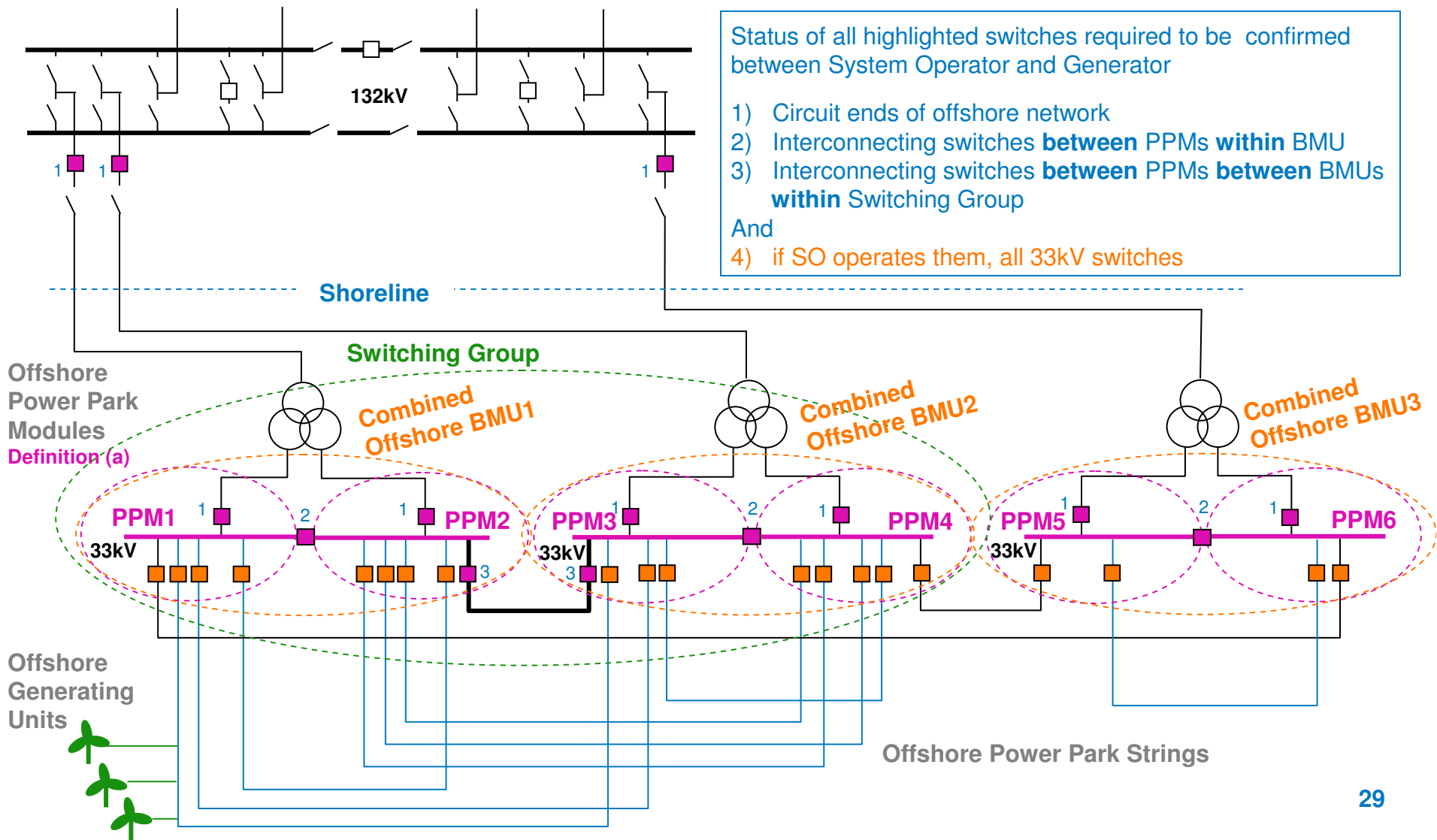

BMU Configuration Diagram Process

- Standard configuration diagram to be agreed by National Grid and generator prior to BCAs being signed
- In operational timescales, National Grid and the generator will coordinate outages and determine whether any changes to the configuration (from standard) are required.
- Where changes are required, these will result in an Amended Configuration diagram, to be produced by National Grid. This will ideally be at week ahead; but by necessity may be at shorter timescales.
- The applicable configuration diagram, plus PPM matrix, will together provide the information required to allow the System Operators duties to be completed.

Proposed Grid Code Changes

- Regarding standard configuration:
 - Proposed Addition to OC2.4.2.1:
 - (m) NGET and the generator shall agree a **Standard BMU Configuration** for the Offshore Power Park Module. NGET shall provide the generator with a **Standard BMU Configuration Diagram** to reflect the agreed standard configuration.

- Regarding amended configuration in operational timescales:
 - Proposed Addition to OC2.4.1.3.5:
 - (iii) NGET will if necessary provide the relevant Generator with an **Amended BMU Configuration Diagram** showing changes to the **Standard BMU Configuration** for the following week. Subsequent changes to the BMU Configuration may be required to maintain secure and economic operation of the transmission system. Under these circumstances NGET will issue a revised diagram as soon as is reasonably practicable.

- New Grid Code definitions:
 - **Standard BMU Configuration** The configuration agreed between the generator and National Grid

 - **Amended BMU Configuration** The configuration agreed through the OC2 process to be adopted during fault or outage conditions